

Operation Manual Multiparameter Transmitter M400



Transmitter Multiparameter M400
52 121 378

Operation Manual Multiparameter Transmitter M400

Content

1	Introduction	7
2	Safety instructions	7
2.1	Definition of equipment and documentation symbols and designations	7
2.2	Correct disposal of the unit	8
3	Unit overview	9
3.1	Overview 1/2DIN	9
3.2	Control/Navigation Keys	10
3.2.1	Menu Structure	10
3.2.2	Navigation keys	10
3.2.2.1	Navigating the menu tree	10
3.2.2.2	Escape	11
3.2.2.3	Enter	11
3.2.2.4	Menu	11
3.2.2.5	Calibration mode	11
3.2.2.6	Info mode	11
3.2.3	Navigation of data entry fields	11
3.2.4	Entry of data values, selection of data entry options	11
3.2.5	Navigation with ↑ in Display	11
3.2.6	“Save changes” dialog	12
3.2.7	Security Passwords	12
3.3	Display	12
4	Installation instruction	13
4.1	Unpacking and inspection of equipment	13
4.1.1	Panel cutout dimensional information – 1/2DIN models	13
4.1.2	Installation procedure	14
4.1.3	1/2DIN version – Assembly	14
4.1.4	1/2DIN version – Dimension drawings	15
4.1.5	1/2DIN version – Pipe mounting	15
4.2	Connection of power supply	16
4.2.1	Housing (wall mount)	16
4.3	Connector PIN definition	17
4.3.1	TB1 and TB2	17
4.3.2	TB3 – Conventional (analog) Conductivity Sensors	17
4.3.3	TB3 – Conventional (analog) pH/ORP Sensors	18
4.3.4	TB3 – Conventional (analog) Dissolved Oxygen	18
4.3.5	TB4 – ISM (digital) Sensors, pH and Dissolved Oxygen	19
4.3.6	TB4 – Optical Oxygen Sensors	19
4.4	Connection of Sensor – pH/ORP	20
4.4.1	Connection of ISM Sensor, pH and Dissolved Oxygen	20
4.4.2	AK9 Cable Assignment	20
4.4.3	Connecting the Sensor to the VP Cable	21
4.4.4	VP Cable Assignment	22
4.4.5	Typical Wiring (Using TB3/TB4)	23
4.4.5.1	Example 1	23
4.4.5.2	Example 2	24
4.4.5.3	Example 3	25
4.4.5.4	Example 4	26
4.5	Connection of Sensor – Dissolved Oxygen	27
4.5.1	Connecting the Sensor to the VP Cable	27
4.5.2	Typical Wiring using TB3	28
4.6	Connection of Optical Dissolved Oxygen	29
4.6.1	Connecting the Optical Sensor to a Cable	29
4.6.2	Optical DO Sensor Cable Assignment using TB4	29
5	Placing transmitter in, or out, of service	30
5.1	Placing transmitter in service	30
5.2	Placing transmitter out of service	30
6	Quick Setup	31

7	Sensor Calibration	32
7.1	Enter Calibration Mode	32
7.2	Conductivity Calibration	32
	7.2.1 One-point Sensor Calibration	33
	7.2.2 Two-point Sensor Calibration (4-electrode sensors only)	33
7.3	Oxygen Calibration	33
	7.3.1 One-Point Sensor Calibration	33
	7.3.2 Two Point Sensor Calibration (only available for Optical Sensors)	34
	7.3.3 Process Calibration	34
7.4	pH Calibration	35
	7.4.1 One point calibration	35
	7.4.2 Two point calibration	36
	7.4.3 Process calibration	36
	7.4.4 mV calibration	36
7.5	Sensor Temperature Calibration	37
	7.5.1 One-Point Sensor Temperature Calibration	37
	7.5.2 Two – Point Sensor Temperature Calibration	37
7.6	Edit Sensor Calibration Constants (only for analog sensor)	38
7.7	Sensor Verification	38
8	Configuration	39
8.2	Measurement	39
	8.2.1 Channel Setup	39
	8.2.2 Temperature Source (Not used with ISM Sensors)	40
	8.2.3 pH/O ₂ Parameter related settings	40
	8.2.3.1 Conductivity Temperature Compensation	40
	8.2.3.2 pH Parameters	41
	8.2.3.3 Dissolved Oxygen Parameters	42
	8.2.4 Set Averaging	42
8.3	Analog Outputs	43
8.4	Setpoints	44
8.5	Alarm/Clean	45
	8.5.1 Alarm	45
	8.5.2 Clean	46
8.6	ISM Set up (only available if an ISM sensor is connected)	46
	8.6.1 Sensor Monitoring	46
	8.6.2 CIP Cycle Limit	47
	8.6.3 SIP Cycle Limit	48
	8.6.4 Autoclaving Cycle Limit	48
	8.6.5 Reset ISM Counter/Timer	49
8.7	Display	49
	8.7.1 Measurement	49
	8.7.2 Resolution	50
	8.7.3 Backlight	50
	8.7.4 Name	50
	8.7.5 ISM Sensor Monitoring (available when ISM sensor connected)	51
8.8	Hold Analog Outputs	51
9	System	52
9.1	Set Language	52
9.2	USB	52
9.3	Passwords	53
	9.3.1 Changing Passwords	53
	9.3.2 Configuring Menu Access for Operator	53
9.4	Set/Clear Lockout	54
9.5	Reset	54
	9.5.1 Reset System	54
	9.5.2 Reset Meter Calibration	54
	9.5.3 Reset Analog Calibration	55
9.6	Set Date & Time	55
10	PID Setup	56
10.1	Enter PID Setup	57
10.2	PID Auto/Manual	57
10.3	Mode	58
	10.3.1 PID Mode	58

10.4	Tune Parameters	59
10.4.1	PID Assignment & Tuning	59
10.4.2	Setpoint & Deadband	60
10.4.3	Proportional Limits	60
10.4.4	Corner Points	60
10.5	PID Display	60
11	Service	61
11.1	Diagnostics	61
11.1.1	Model/Software Revision	61
11.1.2	Digital Input	61
11.1.3	Display	62
11.1.4	Keypad	62
11.1.5	Memory	62
11.1.6	Set Relay	62
11.1.7	Read Relays	63
11.1.8	Set Analog Outputs	63
11.1.9	Read Analog Outputs	63
11.2	Calibrate	64
11.2.1	Calibrate Meter (only for channel A)	64
11.2.1.1	Temperature	64
11.2.1.2	Current	65
11.2.1.3	Voltage	65
11.2.1.4	Rg Diagnostic	66
11.2.1.5	Rr Diagnostics	66
11.2.2	Calibrate Analog	67
11.2.3	Calibrate Unlock	67
11.3	Tech Service	67
12	Info	68
12.1	Messages	68
12.2	Calibration Data	68
12.3	Model/Software Revision	69
12.4	ISM Sensor Info (available when ISM sensor connected)	69
12.5	ISM Sensor Diagnostics (available when ISM sensor connected)	69
13	Maintenance	71
13.1	Front Panel Cleaning	71
14	Troubleshooting	71
14.1	Changing the Fuse	72
14.2	Warning- and Alarm list pH	72
14.3	Warning- and Alarm list O ₂	72
14.4	Warning- and Alarm list Optical O ₂	73
15	Accessories and Spare Parts	74
16	Specifications	75
16.1	General specifications	75
16.2	Electrical specifications	76
16.3	Mechanical specifications	76
16.4	Environmental specifications	76
17	Default tables	77
17.1	General	77
17.2	M400	78
17.3	Error messages	80
18	Warranty	81
19	Buffer tables	82
19.1	Mettler-9	82
19.2	Mettler-10	82
19.3	NIST Technical Buffers	83
19.4	NIST standard buffers (DIN and JIS 19266: 2000-01)	83
19.5	Hach buffers	84
19.6	Ciba (94) buffers	84
19.7	Merck Titrisole, Riedel-de-Haën Fixanale	85
19.8	WTW buffers	85

1 Introduction

Statement of Intended Use – The M400 Multiparameter transmitter is a single- channel online process instrument for measuring various properties of fluids. These include Conductivity, Dissolved Oxygen and pH/ORP. The M400 is not suitable for O₂ gas-phase measurement applications. The M400 is available in three different levels. The level indicates the amount of measurement parameters which can be covered. The parameters are indicated on the label on the back of the system.

The M400 is a unique mixed mode transmitter who can handle conventional sensors (analog) or ISM sensors (digital).

M400 parameter fit guide

Parameter	Type 1		Type 2		Type 3	
	Analog	ISM	Analog	ISM	Analog	ISM
pH/ORP	•	•	•	•	•	•
Conductivity	•	•*	•	•*	•	•*
Oxygen ppm/ppb/traces	–	–	•/–/–	•/–/–	•/•/–	•/•/–
Oxygen optical ppm/ppb	–	–	–	•/–	–	•/•

* Q1/2009

A large four line backlit Liquid Crystal Display conveys measuring data and setup information. The menu structure allows the operator to modify all operational parameters by using keys on the front panel. A menu-lockout feature, with password protection, is available to prevent the unauthorized use of the meter. The M400 Multiparameter transmitter can be configured to use its four analog and/or six relay outputs for process control.

The M400 Multiparameter transmitter is equipped with a USB communication interface. This interface provides real-time data output and complete instrument configuration capabilities for central monitoring via Personal Computer (PC).

2 Safety instructions

This manual includes safety information with the following designations and formats.

2.1 Definition of equipment and documentation symbols and designations



WARNING: POTENTIAL FOR PERSONAL INJURY.



CAUTION: possible instrument damage or malfunction.



NOTE: Important operating information.



On the transmitter or in this manual text indicates: Caution and/or other possible hazard including risk of electric shock (refer to accompanying documents)

The following is a list of general safety instructions and warnings. Failure to adhere to these instructions can result in damage to the equipment and/or personal injury to the operator.

- The M400 Transmitter should be installed and operated only by personnel familiar with the transmitter and who are qualified for such work.
- The M400 Transmitter must only be operated under the specified operating conditions (see section 16).
- Repair of the M400 Transmitter must be performed by authorized, trained personnel only.
- With the exception of routine maintenance, cleaning procedures or fuse replacement, as described in this manual, the M400 Transmitter must not be tampered with or altered in any manner.
- Mettler-Toledo accepts no responsibility for damage caused by unauthorized modifications to the transmitter.
- Follow all warnings, cautions, and instructions indicated on and supplied with this product.
- Install equipment as specified in this instruction manual. Follow appropriate local and national codes.
- Protective covers must be in place at all times during normal operation.
- If this equipment is used in a manner not specified by the manufacturer, the protection provided by it against hazards may be impaired.

WARNINGS:

Installation of cable connections and servicing of this product require access to shock hazard voltage levels.

Main power and relay contacts wired to separate power source must be disconnected before servicing.

Switch or circuit breaker shall be in close proximity to the equipment and within easy reach of the OPERATOR; it shall be marked as the disconnecting device for the equipment.

Main power must employ a switch or circuit breaker as the disconnecting device for the equipment.

Electrical installation must be in accordance with the National Electrical Code and/or any other applicable national or local codes.



NOTE: RELAY CONTROL ACTION: the M400 transmitter relays will always de-energize on loss of power, equivalent to normal state, regardless of relay state setting for powered operation. Configure any control system using these relays with fail-safe logic accordingly.



NOTE: PROCESS UPSETS: Because process and safety conditions may depend on consistent operation of this transmitter, provide appropriate means to maintain operation during sensor cleaning, replacement or sensor or instrument calibration.



NOTE: This is a 4-wire-product with an active 4–20 mA analog output. Please do not supply to Pin1–Pin6 of TB2.

2.2 Correct disposal of the unit

When the transmitter is finally removed from service, observe all local environmental regulations for proper disposal.

3 Unit overview

The M400 models are available in 1/2DIN case size. The M400 models provide an integral IP65 housing for wall- or pipemount.

3.1 Overview 1/2DIN

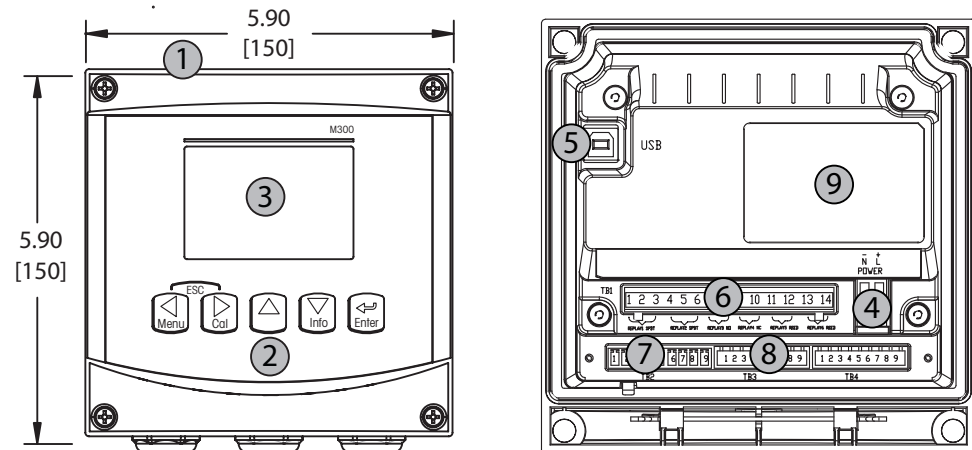

- 1 – Hard Polycarbonate case
- 2 – Five Tactile-Feedback Navigation Keys
- 3 – Four-line LCD Display
- 4 – Power Supply Terminals
- 5 – USB Interface Port
- 6 – Relay Output Terminals
- 7 – Analog Output/Digital Input Terminals
- 8 – Sensor Input Terminals (analog TB, digital TB)
- 9 – List of parameters to be measured with this unit

3.2 Control/Navigation Keys

3.2.1 Menu Structure

Below is the structure of the M400 menu tree:

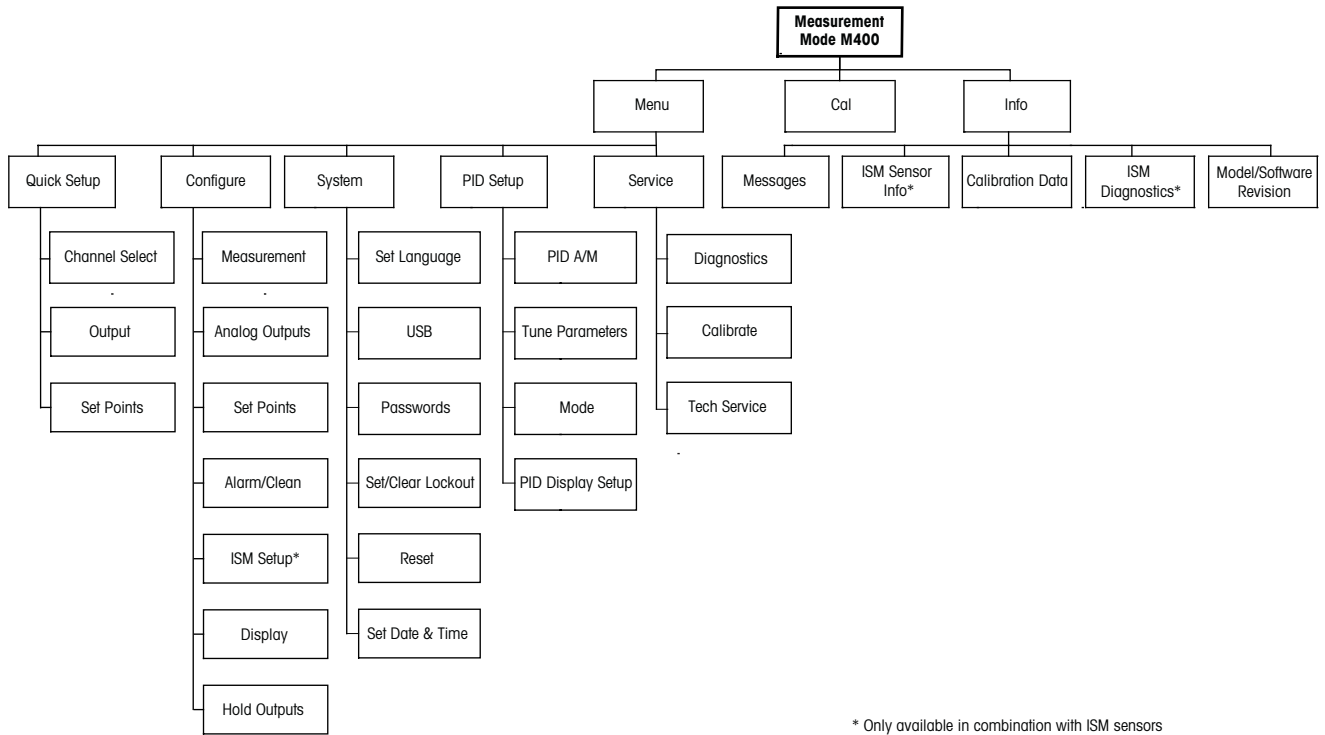

3.2.2 Navigation keys



3.2.2.1 Navigating the menu tree

Enter the desired main Menu branch with the ◀ ▶ or ▲ keys. Use the ▲ and ▼ keys to navigate through the selected Menu branch.



NOTE: In order to back up one menu page, without escaping to the measurement mode, move the cursor under the UP Arrow character (↑) at the bottom right of the display screen and press [Enter].

3.2.2.2 Escape

Press the ◀ and ▶ key simultaneously (escape) to return to the Measurement mode.

3.2.2.3 Enter

Use the ↵ key to confirm action or selections.

3.2.2.4 Menu

Press the ◀ key to access the main Menu.

3.2.2.5 Calibration mode

Press the ▶ key to enter Calibration Mode.

3.2.2.6 Info mode

Press the ▼ key to enter Info Mode

3.2.3 Navigation of data entry fields

Use the ▶ key to navigate forward or the ◀ key to navigate backwards within the changeable data entry fields of the display.

3.2.4 Entry of data values, selection of data entry options

Use the ▲ key to increase or the ▼ key to decrease a digit. Use the same keys to navigate within a selection of values or options of a data entry field.



NOTE: Some screens require configuring multiple values via the same data field (ex: configuring multiple setpoints). Be sure to use the ▶ or ◀ key to return to the primary field and the ▲ or ▼ key to toggle between all configuration options before entering to the next display screen.

3.2.5 Navigation with ↑ in Display

If a ↑ is displayed on the bottom right hand corner of the display, you can use the ▶ or the ◀ key to navigate to it. If you click [ENTER] you will navigate backwards through the menu (go back one screen). This can be a very useful option to move back up the menu tree without having to exit into the measuring mode and re-enter the menu.

3.2.6 "Save changes" dialog

Three options are possible for the "Save changes" dialog: Yes & Exit (Save changes and exit to measuring mode), "Yes & ↑" (Save changes and go back one screen) and "No & Exit" (Don't save changes and exit to measuring mode). The "Yes & ↑" option is very useful if you want to continue configuring without having to re-enter the menu.

3.2.7 Security Passwords

The M400 transmitter allows a security lock-out of various menus. If the security lock-out feature of the transmitter has been enabled, a security password must be entered to allow access to the menu. See section 9.3 for more information.

3.3 Display



NOTE: In the event of an alarm or other error condition the M400 Transmitter will display a flashing  in the upper right corner of the display. This symbol will remain until the condition that caused it has been cleared.



NOTE: During calibrations (Channel A), clean, Digital In with Analog Output/Relay/USB in Hold state, a flashing "H" (Hold) will appear in the upper left corner of the display. During calibration on Channel B, a flashing "H" (Hold) will appear in the second line. Change to B and flash. This symbol will remain for 20 sec., after end of calibration. This symbol will remain for 20 seconds until after the calibration or clean is completed. This symbol will also disappear when Digital In is deactivated.



NOTE: Channel A (A is shown on the left side of the display) indicates that a conventional Sensor is connected to the transmitter.

Channel B (B is shown on the left side of the display) indicates, that an ISM Sensor is connected to the transmitter.

The M400 is a single input channel transmitter, and only one sensor can be connected at the same time.

4 Installation instruction

4.1 Unpacking and inspection of equipment

Inspect the shipping container. If it is damaged, contact the shipper immediately for instructions. Do not discard the box.

If there is no apparent damage, unpack the container. Be sure all items shown on the packing list are present.

If items are missing, notify Mettler-Toledo immediately

4.1.1 Panel cutout dimensional information – 1/2DIN models

1/2DIN Model transmitters are designed with an integral rear cover for stand-alone wall mount installation.

The unit may also be wall mounted using the integral rear cover. See installation instructions in Section 4.1.2.

Below are cut-out dimensions required by the 1/2DIN models when mounted within a flat panel or on a flat enclosure door. This surface must be flat and smooth. Textured or rough surfaces are not recommended and may limit the effectiveness of the gasket seal provided.

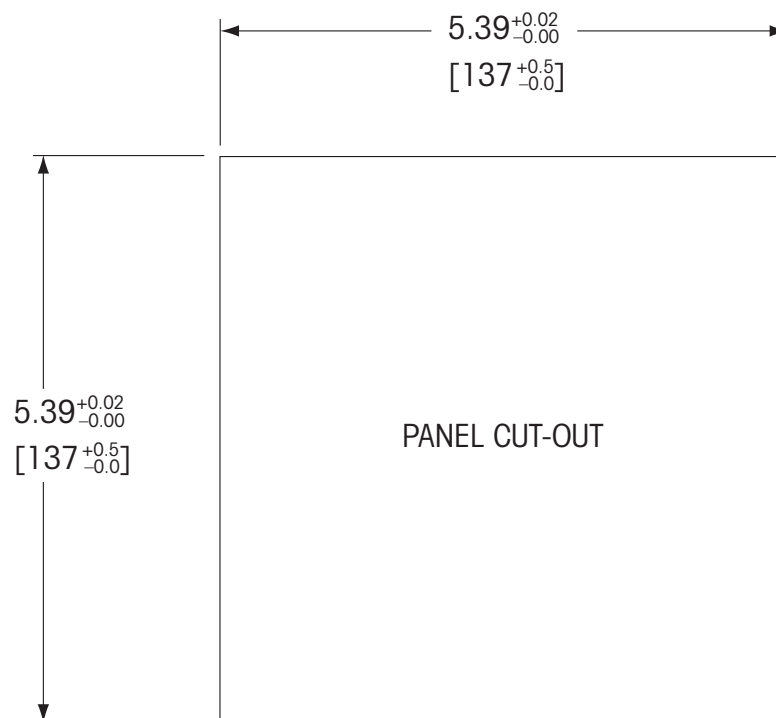

Optional hardware accessories are available that allow for panel- or pipe-mount. Refer to Section [15](#) for ordering information.

4.1.2 Installation procedure

For Wall Mount:

- Remove rear cover from front housing.
- Start by unscrewing the four screws located on the face of the transmitter, in each corner. This allows the front cover to swing away from the rear housing.
- Remove the hinge-pin by squeezing the pin from each end. This allows the front housing to be removed from the rear housing
- Drill out wall-mount breakthroughs in the rear housing.
- Mount rear housing to wall using appropriate mounting hardware for wall surface. Be sure it is level and securely fastened and the installation adheres to any and all clearance dimensions required for transmitter service and maintenance.
- Insert two black protective covers (supplied with the M400 transmitter) over the fixing hardware and into the space on the inside back cover, as shown in the drawing below. This is necessary to maintain unit integrity.
- Replace the front housing to the rear housing. The unit is ready to be wired.

For Pipe Mount:

- Use only manufacturer-supplied components for pipe-mounting the M400 transmitter and install per the supplied instructions. See section [15](#) for ordering information.

4.1.3 1/2DIN version – Assembly

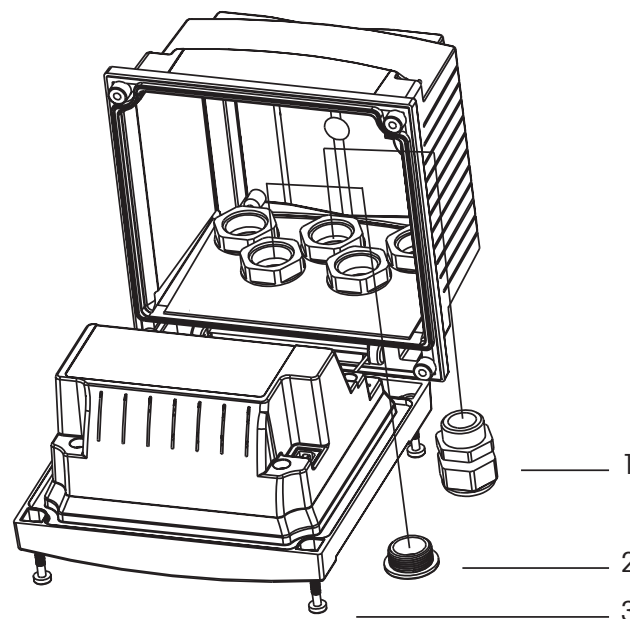

- 1** 3 Pg 13.5 cable glands
- 2** 2 plastic plugs
- 3** 4 screws

4.1.4 1/2DIN version – Dimension drawings

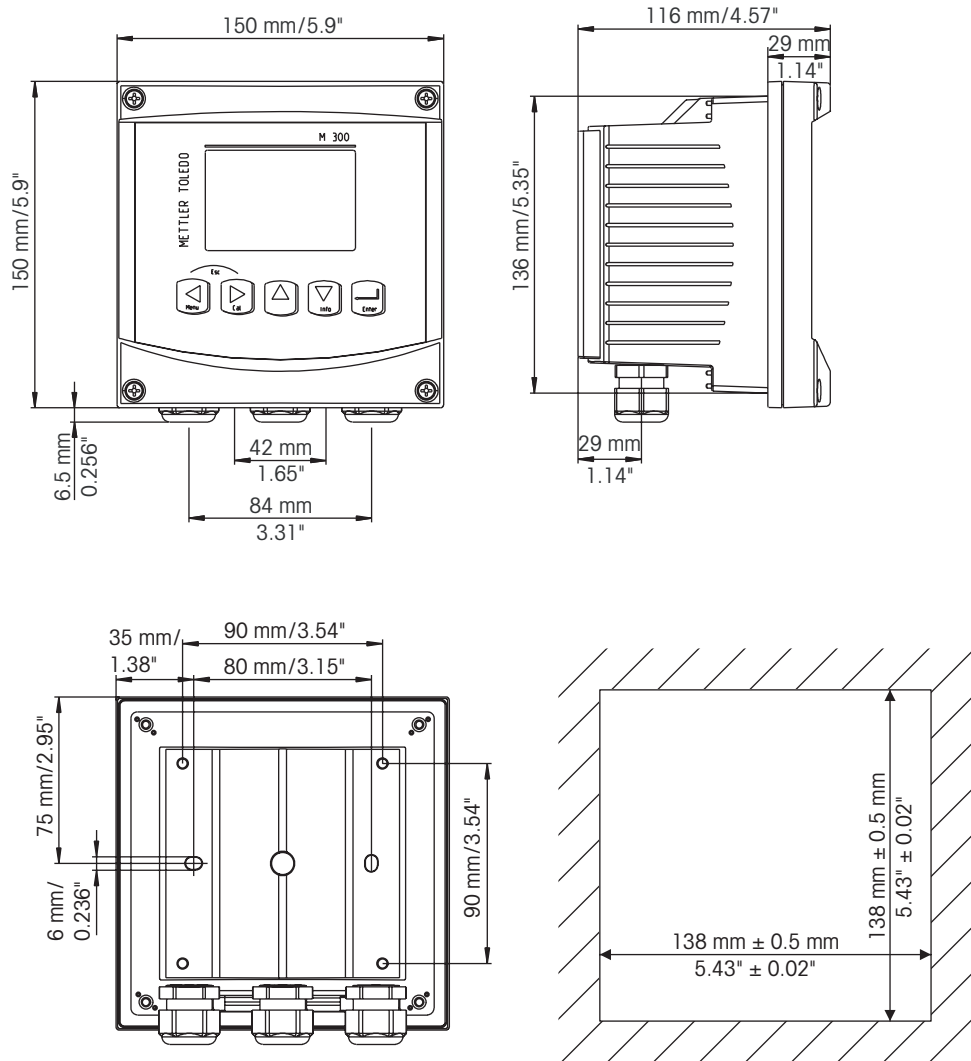

4.1.5 1/2DIN version – Pipe mounting

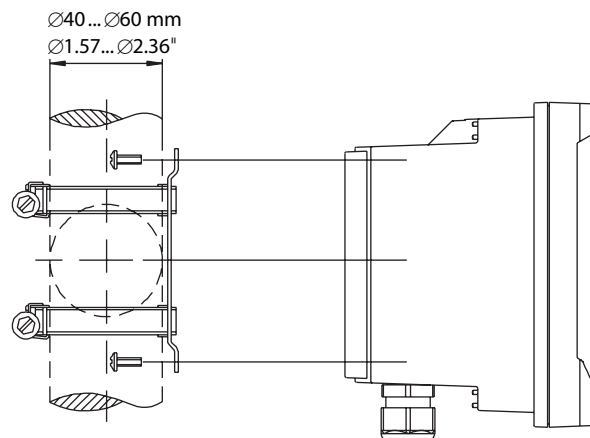

4.2 Connection of power supply

All connections to the transmitter are made on the rear panel of all models.



Be sure power to all wires is turned off before proceeding with the installation. High voltage may be present on the input power wires and relay wires.

A two-terminal connector on the rear panel of all M400 models is provided for power connection. All M400 models are designed to operate from a 20–30 VDC or a 100 to 240 VAC power source. Refer to specifications for power requirements and ratings and size power wiring accordingly (AWG 14, wire cross-section $\leq 2.5 \text{ mm}^2$).

The terminal block for power connections is labeled “Power” on the rear panel of the transmitter. One terminal is labeled **-N** for the Neutral wire and the other **+L** for the Line (or Load) wire. The terminals are suitable for single wires and flexible leads up to 2.5 mm^2 (AWG 14). There is no earth ground terminal on the transmitter. For this reason the internal power wiring within the transmitter is double insulated and the product label designates this using the  symbol.

4.2.1 Housing (wall mount)

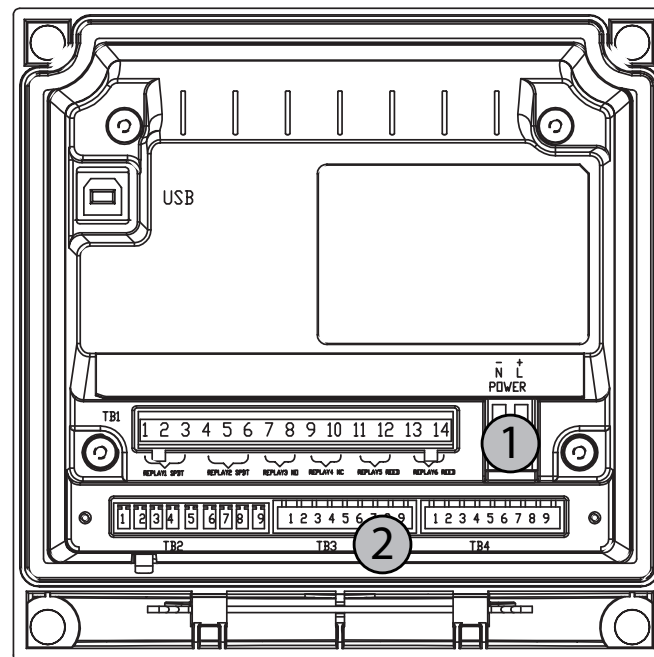

- 1 Connection of power supply
- 2 Terminal for sensors

4.3 Connector PIN definition

4.3.1 TB1 and TB2

Power connections are labeled

-N for Neutral and +L for Line, for 100 to 240 VAC or 20–30 VDC.

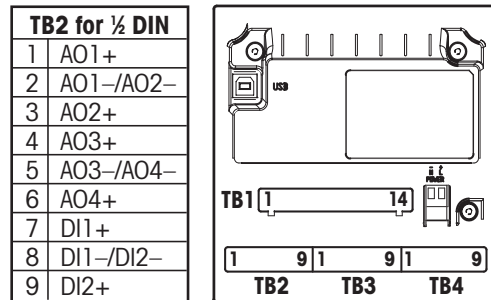

TB1 for ½ DIN			
1	NO1	8	NC5
2	COM1	9	COM6
3	NC1	10	NO6
4	NO2	11	NO3
5	COM2	12	COM3
6	NC2	13	NO4
7	COM5	14	COM4

NO = normally open (contact open if un-actuated). AO = Analog Output

NC = normally closed (contact closed if un-actuated). DI = Digital Input



NOTE: This is a 4-wire-product with an active 4–20 mA analog output.

Please do not supply to Pin1–Pin6 of TB2.

4.3.2 TB3 – Conventional (analog) Conductivity Sensors

Pin no.	Sensor wire Color	Function
1	white	Cnd inner 1
2	white/blue	Cnd outer 1
3	blue	Cnd inner 2
4	black	Cnd outer 2/Shield
5	–	not used
6	bare shield	RTD ref/GND
7	red	RTD sense
8	green	RTD
9	–	+5V

Transparent not used.

4.3.3 TB3 – Conventional (analog) pH/ORP Sensors

pH/ORP sensors use 52 300 1XX series VP cables, or 10 001 XX02 series AS9 cables (ORP only).

Pin no.	Sensor wire Color	Function
1	Coax inner/transparent	Glass
2		not used
3*	Coax shield/red	Reference
4*	green/yellow, blue	Solution GND/Shield
5	–	not used
6	white	RTD ref/GND
7		RTD sense
8	green	RTD
9	–	+5V
	grey (no connection)	

Take care that AS9 cable and AK9 cable have the same configuration. So, if you want AS9 cable with InPro 2000 and AK9 cable with InPro 3030 connect to TB3, do it as DPAS sensor.

Pin no. 1 – Sensing (electrode).

Pin no. 3 – Reference (Install jumper 3 to 4).



NOTE: * Install Jumper 3 to 4 when used without Solution Ground.

4.3.4 TB3 – Conventional (analog) Dissolved Oxygen

These sensors use 52 300 1XX series VP cables.

Pin no.	Sensor wire Color	Function
1*	–	not used
2	Coax Shield/red	Anode
3*	–	not used
4*	green/yellow	Shield/GND
5	Coax Inner/transparent	Cathode
6	white, grey	Temperature, Guard
7	–	not used
8	green	Temperature
9	–	+5V

Blue wire not used.



NOTE: * Install Jumper (supplied) 1 to 3 to 4 when using InPro 6900 (ppb measurement).

4.3.5 TB4 – ISM (digital) Sensors, pH and Dissolved Oxygen

The wiring of the digital 9 terminal connectors is:

Pin no.	Sensor wire Color	Function
1	–	24 VDC
2	–	GND (24 VDC)
3	Cable core	1-Wire
4	Shield	GND (5 VDC)
5	–	No connection
6	–	GND (5 VDC)
7	–	RS485–
8	–	RS485+
9	–	5 VDC

- ISM digital sensors can only be connected on TB4.
- Analog sensors can only be connected on TB3.

4.3.6 TB4 – Optical Oxygen Sensors

Pin no.	Sensor wire Color	Function
1	brown	24 VDC
2	black	GND (24 VDC)
3	–	1-Wire
4	grey and yellow	GND (5 VDC)
5	–	No connection
6	–	GND (5 VDC)
7	blue	RS485–
8	white	RS485+
9	–	5 VDC

4.4 Connection of Sensor – pH/ORP

4.4.1 Connection of ISM Sensor, pH and Dissolved Oxygen

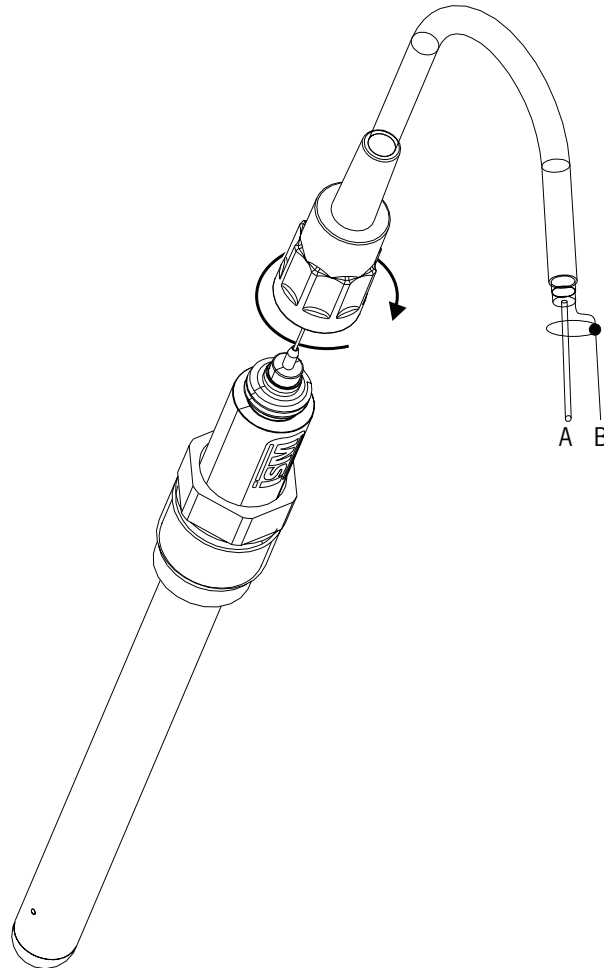

NOTE: Connect the Sensor and screw the plug head clockwise (hand tight).

4.4.2 AK9 Cable Assignment

- A: 1-wire data (transparent)
- B: Ground/shield

4.4.3 Connecting the Sensor to the VP Cable

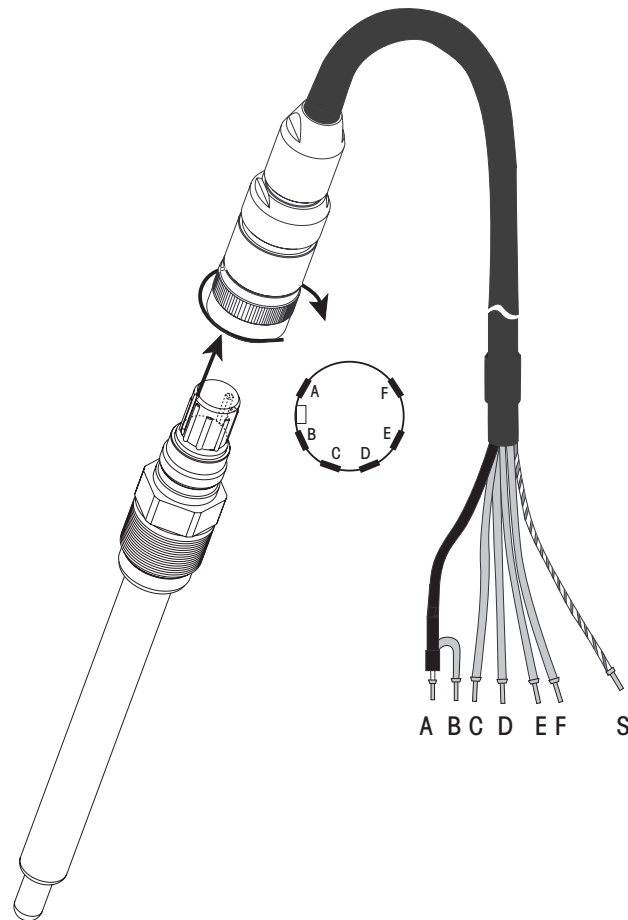

NOTE: Cable lengths > 20 m can worsen the response during pH measurement. Be sure to observe the sensor instruction manual.

4.4.4 VP Cable Assignment

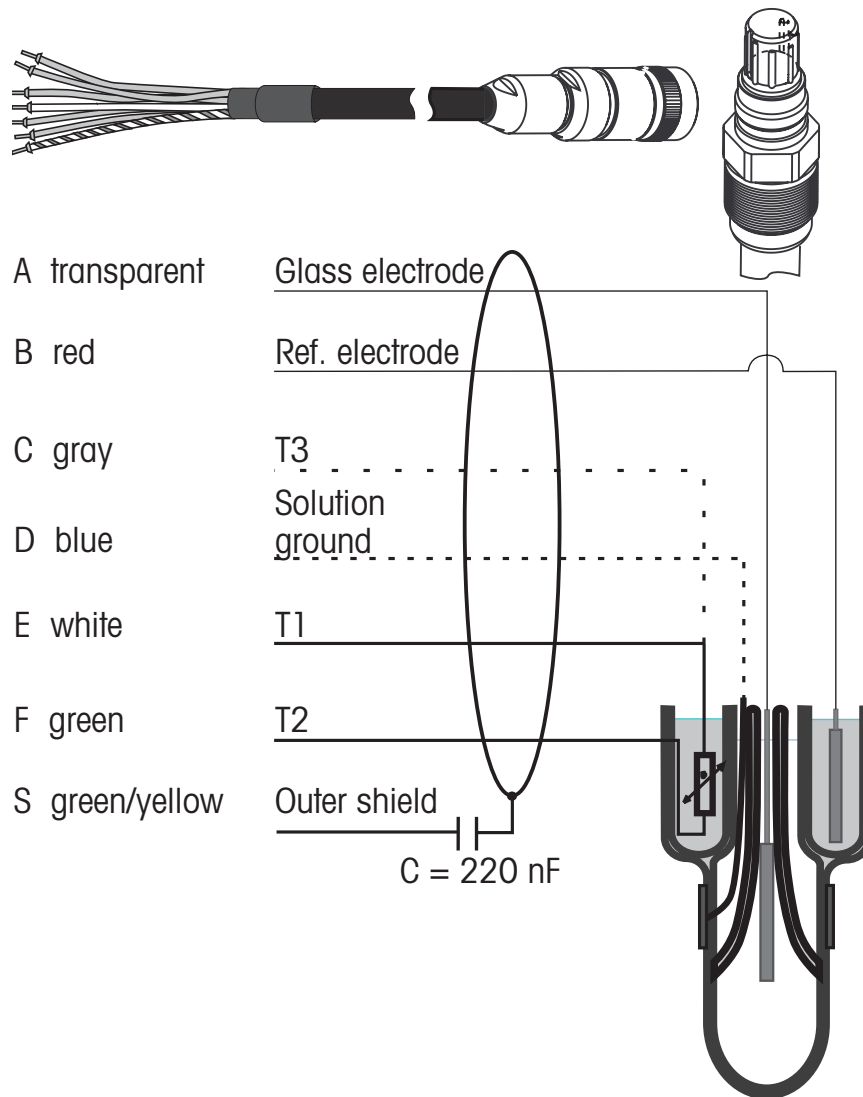

T1/T2 = Temperature probe for 2-wire connection
 T3 = Additional connection for temperature probe (3-wire connection)

4.4.5 Typical Wiring (Using TB3/TB4)

4.4.5.1 Example 1

pH measurement without Solution Ground

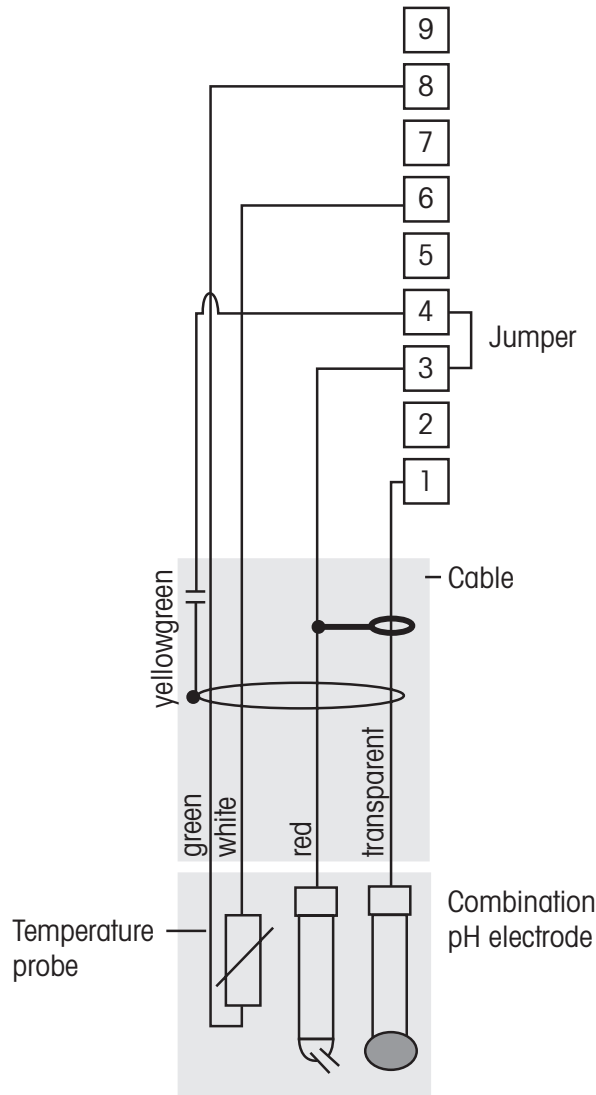

NOTE: Jumper Terminals 3 and 4.

Wire colors only valid for connection with VP cable; blue and grey not connected.

- 1 – Glass
- 2 – Not used
- 3 – Reference
- 4 – Shield/GND
- 5 – Not used
- 6 – Solution GND/RTD ret
- 7 – Not used
- 8 – RTD
- 9 – Not used



4.4.5.2 Example 2

pH measurement with Solution Ground

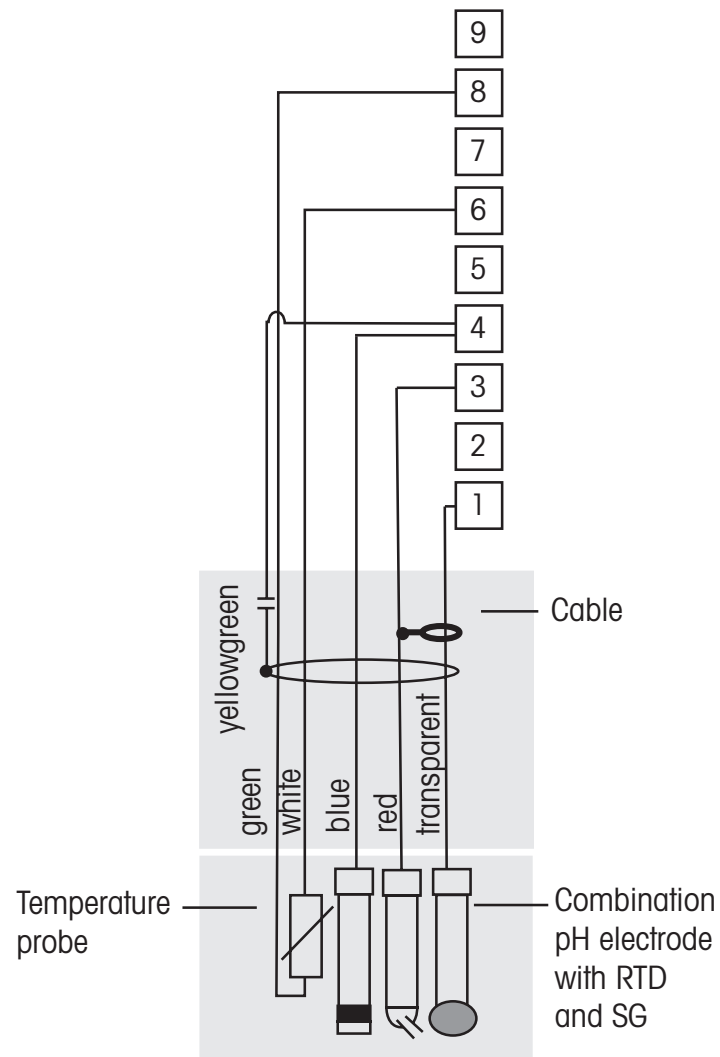

NOTE: Wire colors only valid for connection with VP cable, grey not connected.

- 1 – Glass
- 2 – Not used
- 3 – Reference
- 4 – Shield/Solution GND
- 5 – Not used
- 6 – GND/RTD ref
- 7 – Not used
- 8 – RTD
- 9 – Not used

4.4.5.3 Example 3

ORP (redox) measurement (temperature optional)

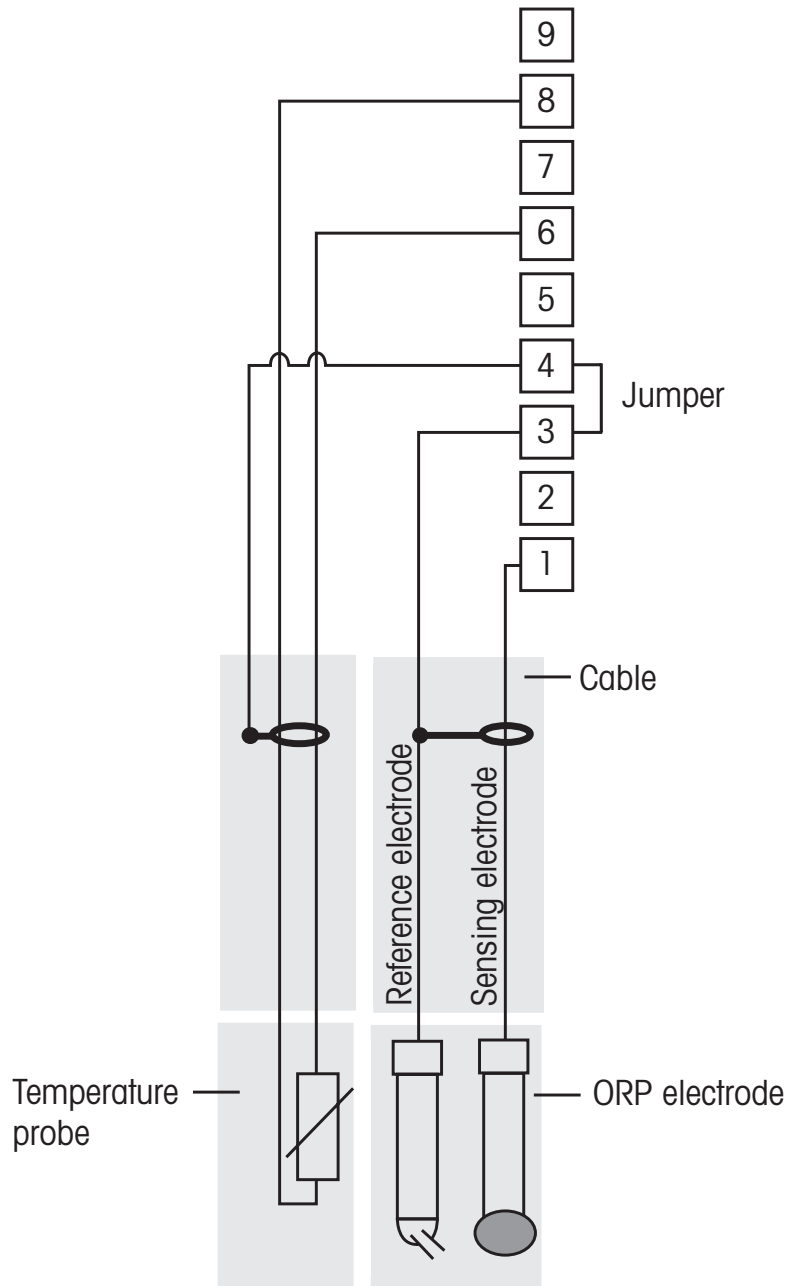

NOTE: Jumper Terminal 3 and 4

- 1 – Platinum
- 2 – Not used
- 3 – Reference
- 4 – Shield/GND
- 5 – Not used
- 6 – RTD ref
- 7 – Not used
- 8 – RTD
- 9 – Not used

4.4.5.4 Example 4

ORP measurement with pH Solution ground electrode (e.g. InPro 3250SG, InPro 4800SG).

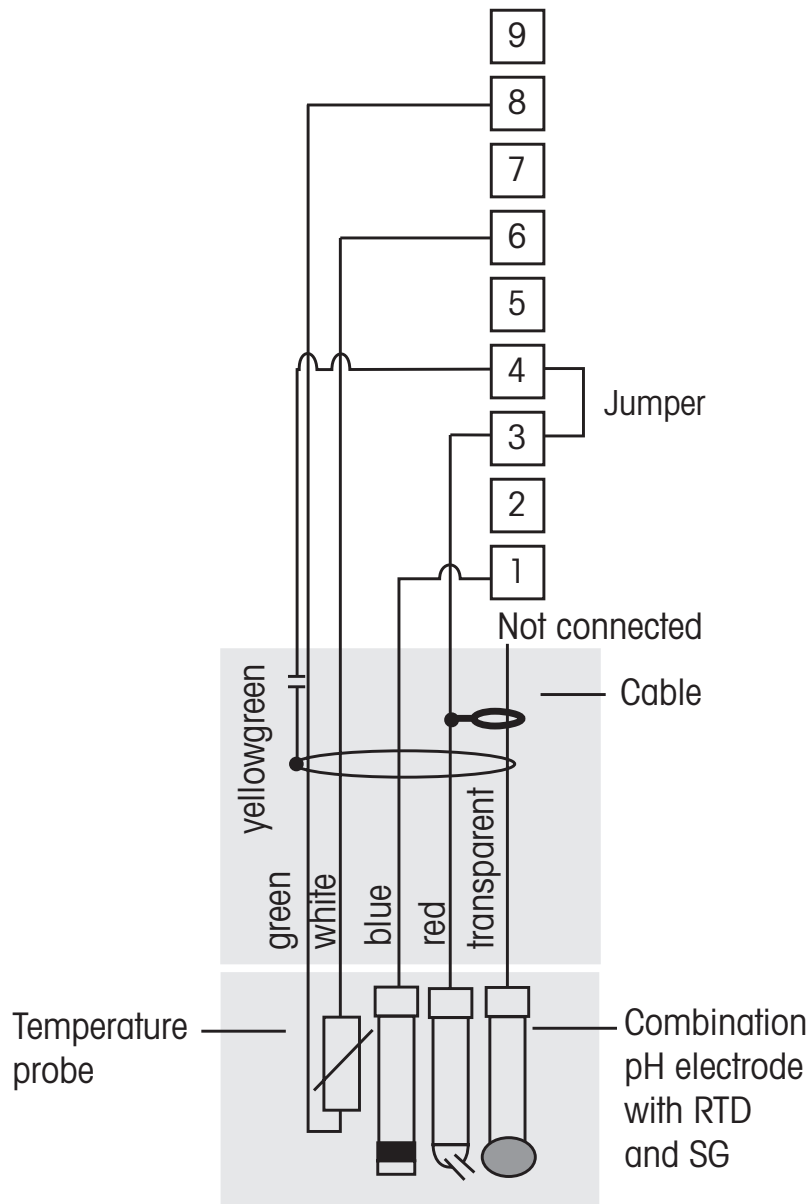

NOTE: Jumper Terminal 3 and 4

- 1 – Platinum
- 2 – Not used
- 3 – Reference
- 4 – Shield/GND
- 5 – Not used
- 6 – RTD ret
- 7 – Not used
- 8 – RTD
- 9 – Not used

4.5 Connection of Sensor – Dissolved Oxygen

4.5.1 Connecting the Sensor to the VP Cable

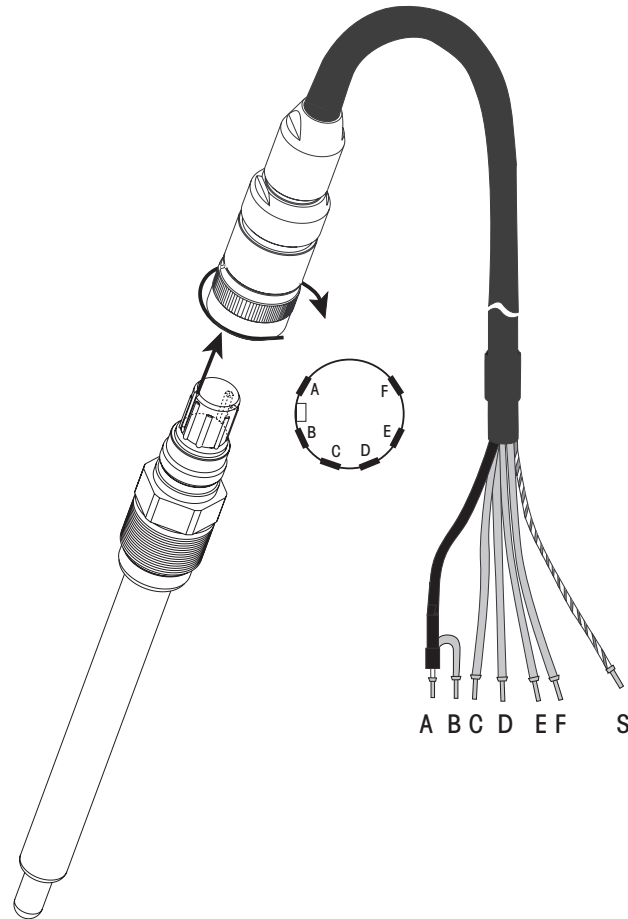

NOTE: Be sure to observe the sensor instruction manual.

4.5.2 Typical Wiring using TB3

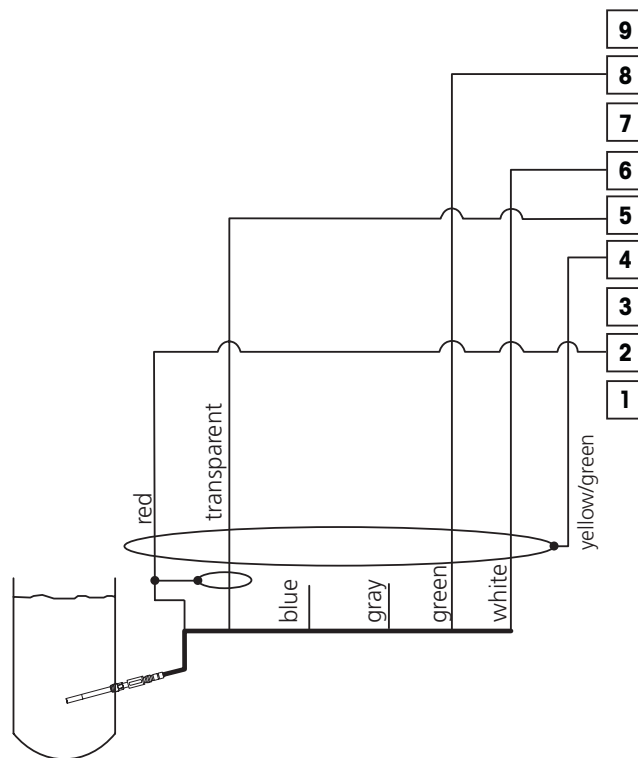

NOTE: Wire colors only valid for connection with VP cable, blue not connected.



NOTE: Install Jumper (supplied) 1 to 3 to 4 when using InPro 6900 (ppb measurement).

M400 connector:

- 1 – not used
- 2 – Anode
- 3 – not used
- 4 – Shield/GND
- 5 – Cathode
- 6 – NTC ret, Guard
- 7 – Not used
- 8 – NTC 2
- 9 – not used

4.6 Connection of Optical Dissolved Oxygen

4.6.1 Connecting the Optical Sensor to a Cable

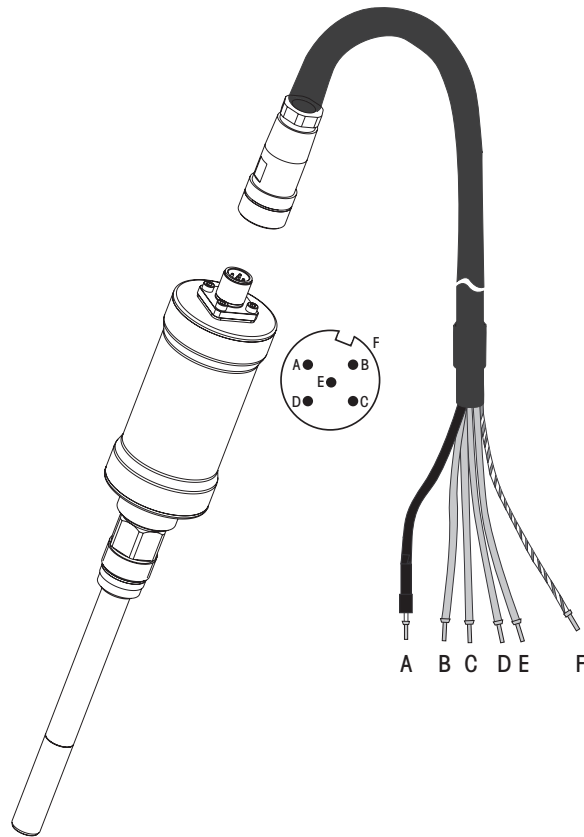

NOTE: Connect the Sensor and screw the plug head clockwise (hand tight).

4.6.2 Optical DO Sensor Cable Assignment using TB4

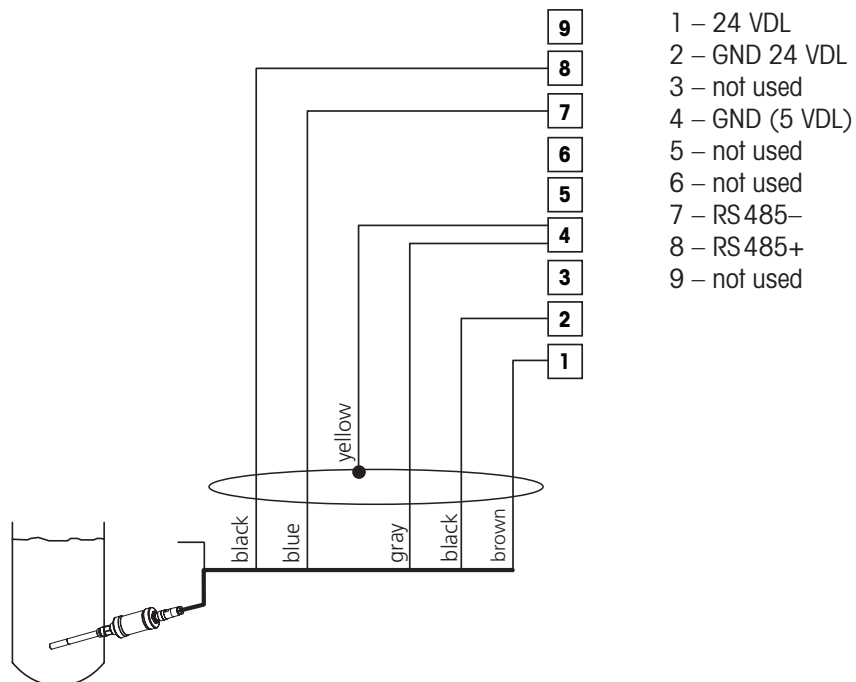

5 Placing transmitter in, or out, of service

5.1 Placing transmitter in service



After connecting the transmitter to power supply circuit, it will be active as soon as the circuit is powered.

5.2 Placing transmitter out of service

First disconnect the unit from the main power source, then disconnect all remaining electrical connections. Remove the unit from the wall/panel. Use the installation instruction in this manual as reference for dis-assembling mounting hardware.
All transmitter settings stored in memory are non volatile.

6 Quick Setup

(PATH: Menu/Quick Setup)

Select Quick Setup and press the [ENTER] key. Enter the security code if necessary (see section 9.3)



Note: Please find the complete description of the Quick Setup routine described in the separate booklet "Quick Setup Guide for Transmitter M400" enclosed in the box.



Note: Refer to section 3.3 for information on menu navigation.

7 Sensor Calibration

(PATH: Cal)

The calibration key ► allows the user one-touch access to Sensor calibration and verification features.



NOTE: During Calibration on Channel A, a flashing "H" (Hold) in the upper left corner of the display indicates a calibration is in process with a Hold condition active. (The hold output function needs to be activated.) See also chapter 3.3.

7.1 Enter Calibration Mode

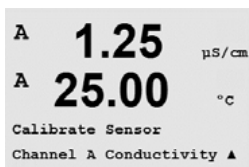

While in Measurement mode press the ► key.
Press the ▲ or ▼ key to select the type of calibration desired.

After selecting "Sensor", use the ► key to move to the next line. Select the channel "A" or "B" to be calibrated. Select the desired Sensor Calibration task. The choices for each sensor type are:
Conductivity = Conductivity, Resistivity, Temperature*, Edit*, Verify
Oxygen = Oxygen, Temperature*, Edit*, Verify
pH = pH, mV, Temperature*, Edit pH*, Edit mV, Verify
Press [ENTER].

* only on channel "A"

After every successful calibration, the three options are available:

- Adjust: Calibration values will be overtaken and used for the measurement. Additionally, the data will be stored in the calibration history*.
 - Calibrate: Calibration values will be stored in the calibration history* for documentation, but will not be used for the measurement. The calibration values from the last valid Adjustment will be further used for the measurement.
 - Abort: Calibration values will be discarded.
- * only available with ISM sensors

7.2 Conductivity Calibration

This feature provides the ability to perform a one-point or two-point Conductivity "Sensor" calibration. The procedure described below works for both types of calibrations. There is no reason to perform a two-point calibration on a two-electrode conductivity sensor. Four electrode sensors do require a two-point calibration.



NOTE: When performing calibration on a conductivity sensor, results will vary depending on the methods, calibration apparatus and/or quality of reference standards used to perform the calibration.

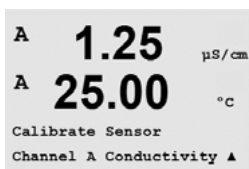

Enter Conductivity Sensor Calibration mode as described in section 7.1.

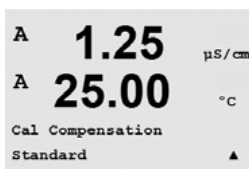

Choose "standard" or "linear" compensation mode.
Press [ENTER].

7.2.1 One-point Sensor Calibration

(Display reflects typical Conductivity Sensor calibration)

```
A 1.25 µS/cm
A 25.00 °C
Conductivity Calibration
Type = 1 point ▲
```

Select 1 point Calibration and press [ENTER].

Enter the Value of calibration Point 1 and then press the [ENTER] key to start calibration. The value in the 2nd text line is the actual measured value from the sensor prior to calibration.

```
A 1.25 µS/cm
A 25.00 °C
A Point1 = 1.413 µS/cm
A C = 1.250 µS/cm ▲
```

After the calibration the Multiplier or slope calibration factor "M" and the Adder or offset calibration factor "A" are displayed.

After a successful calibration, the calibration values are taken over and stored in the cal history (Adjust), only stored in the cal history (Calibrate) or aborted.

```
A 1.25 µS/cm
A 25.00 °C
C M=0.1000 A=0.0000
Save Calibration Yes ▲
```

7.2.2 Two-point Sensor Calibration (4-electrode sensors only)

Enter Conductivity Sensor Calibration mode as described in section 7.1. Select 2 point Calibration and press [ENTER].

```
A 1.25 µS/cm
A 25.00 °C
Conductivity Calibration
Type = 2 point ▲
```

CAUTION: Rinse sensors with a high-purity water solution between calibration points to prevent contamination of the reference solutions.

Enter the Value of Point 1 and press the [ENTER] key. Place the sensor into the second reference solution.

Enter the Value of Point 2 and press the [ENTER] key to start the calibration.

```
A 1.25 µS/cm
A 25.00 °C
A Point2 = 0.055 µS/cm
A C = 0.057 µS/cm ▲
```

After the calibration the Multiplier or slope calibration factor "M" and the Adder or offset calibration factor "A" are displayed.

After a successful calibration, the calibration values are taken over and stored in the cal history (Adjust), only stored in the cal history (Calibrate) or aborted.

```
A 1.25 µS/cm
A 25.00 °C
C M=0.1000 A=0.0000
Save Calibration Yes ▲
```

7.3 Oxygen Calibration

Dissolved Oxygen calibration is performed as either a one-point or process calibration.

7.3.1 One-Point Sensor Calibration

Before air calibration, for highest accuracy, enter the barometric pressure and relative humidity, as described in section 8.2.3.3.

Enter Oxygen Calibration mode as described in section 7.1.

A DO sensor calibration is always either a one point Air (Slope) or a Zero (Offset) calibration. A one point slope calibration is done in air and a one point offset calibration is done at 0 ppb DO. A one-point zero dissolved oxygen calibration is available but not normally recommended since zero DO is very hard to achieve.

```
A 1.25 µS/cm
A 25.00 °C
Calibrate Sensor
Channel B Oxygen ▲
```

The calibration of an optical sensor is always a calibration of the phase of the fluorescence signal towards the internal reference. During a one point calibration (Air or zero) only the phase at this point is measured and the phase at the other point (Air or Zero) is internally calculated. A zero-point calibration is only recommended if high accuracy at low oxygen level (below 5% Air) is needed.

Select 1 point followed by either Slope (Phi 100) or ZeroPt (Phi 0) as the calibration type. Press [ENTER].

```
A 1.25 µS/cm
A 25.00 °C
O2 Calibration
Type = 1 point Slope ▲
```

Enter the value for Point 1 including a decimal point and units. The value in the second text line is the value being measured by the transmitter and sensor in the units selected by the user. Press [ENTER] when this value is stable to perform the calibration.

```
A 1.25 µS/cm
A 25.00 °C
B Point1 = 100.0 ppb
B O2 = 101.3 ppb ▲
```

After the calibration the slope calibration factor S (Phi 100) and the offset calibration factor Z (Phi 0) are displayed.

After a successful calibration, the calibration values are taken over and stored in the cal history (Adjust), only stored in the cal history (Calibrate) or aborted.

```
A 1.25 µS/cm
A 25.00 °C
O2 S=0.1000 Z=0.0000
Save Calibration Yes ▲
```

7.3.2 Two Point Sensor Calibration (only available for Optical Sensors)

A 2-points calibration is a combination of first a calibration in air (100%) where a new phase P100 is measured and then a calibration in nitrogen (0%) where a new phase P0 is measured. This calibration routine gives the most accurate calibration curve over the whole measuring range.

7.3.3 Process Calibration

Enter Oxygen Calibration mode as described in section 7.1.

Select Process followed by either Slope or ZeroPt (Phi 100 or Phi 0) as the calibration type. Press [ENTER]

```
A 1.25 µS/cm
A 25.00 °C
O2 Calibration
Type = Process Slope ▲
```

Take a sample and press the [ENTER] key again to store the current measuring Value. To show the ongoing Calibration Process, A or B (depending on the channel) is blinking in the display.

```
A 1.25 µS/cm
A 25.00 °C
B Point1 = 100.0 ppb
B O2 = 101.3 ppb ▲
```

After determining the O₂ Value of the Sample press the ► key again to proceed with the calibration. Enter the O₂ value of the sample then press the [ENTER] key to start calibration.

After a successful calibration, the calibration values are taken over and stored in the cal history (Adjust), only stored in the cal history (Calibrate) or aborted.

```
A 1.25 µS/cm
A 25.00 °C
O2 S=0.1000 Z=0.0000
Save Calibration Yes ▲
```

During a process calibration of an optical Sensor the phase of the fluorescence light at a point between 5% and 100% air is measured and the phases at 100% and 0% are calculated to determine a new calibration curve.

Process calibration at oxygen values below 5% air saturation is only available for M400 Type 3 in combination with InPro 6970 i.

The InPro 6880 i and InPro 6870 i only provide process calibration at oxygen values above 5% air saturation.

7.4 pH Calibration

For pH sensors, the M400 transmitter features one-point, two-point (Auto or Manual mode) or process calibration with 8 preset buffer sets or manual buffer entry. Buffer values refer to 25 °C. To calibrate the instrument with automatic buffer recognition, you need a standard pH buffer solution that matches one of these values. (See section [8.2.3.2](#) for configuring modes and selecting buffer sets.) Please select the correct buffer table before using automatic calibration (see chapter 19).

After every successful calibration, the three following options are available:

Adjust: Calibration values are taken over and used for the measurement. Additionally, the data's will be stored in the calibration history.

Calibrate: Calibration values will be stored in the calibration history, but will be not used for the measurement. The calibration values from the last valid Adjustment will be further used for the measurement.

Abort: Calibration values will be aborted.

Enter pH Calibration mode as described in section [7.1](#).

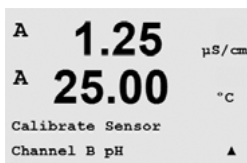

7.4.1 One point calibration

Select 1 point Calibration.

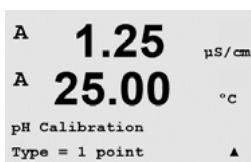

Place the electrode in the buffer solution and press the [ENTER] key to start the calibration.

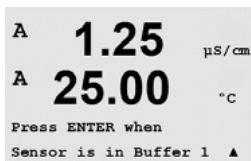

Auto mode: The display shows the buffer that the transmitter has recognized (Point 1) and the measured value.

Manual mode: Enter the buffer value and press [ENTER] to proceed.

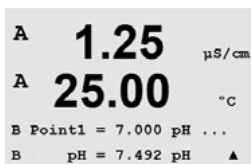

As soon as the drift conditions have stabilized (or [ENTER] pressed in manual mode) the display changes to show the slope calibration factor S and the offset calibration factor Z.

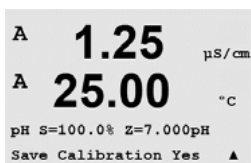

After a successful calibration, the calibration values are taken over and stored in the cal history (Adjust), only stored in the cal history (Calibrate) or aborted.

7.4.2 Two point calibration

A 1.25 µS/cm
A 25.00 °C
pH Calibration
Type = 2 point ▲

Select 2 point Calibration.

Place the electrode in the first buffer solution and then press the [ENTER] key.

Auto mode: The display shows the buffer that the transmitter has recognized (Point 1) and the measured value.

Manual mode: Enter the buffer value and press [ENTER] to proceed.

A 1.25 µS/cm
A 25.00 °C
B Point2 = 10.53 pH ...
B pH = 11.01 pH ▲

As soon as the drift conditions have stabilized (or [ENTER] pressed in manual mode) the display changes and prompts you to place the electrode in the second buffer solution.

As soon as the drift conditions have stabilized (or [ENTER] pressed in manual mode) the display changes to show the slope calibration factor S and the offset calibration factor Z.

A 1.25 µS/cm
A 25.00 °C
pH S=100.0% Z=7.000pH
Save Calibration Yes ▲

After a successful calibration, the calibration values are taken over and stored in the cal history (Adjust), only stored in the cal history (Calibrate) or aborted.

7.4.3 Process calibration

A 1.25 µS/cm
A 25.00 °C
pH Calibration
Type = Process ▲

Select Process Calibration.

A 1.25 µS/cm
A 25.00 °C
pH S=100.0% Z=7.000pH
Save Calibration Yes ▲

Take a sample and press the [ENTER] key again to store the current measuring Value. To show the ongoing Calibration Process, A or B (depending on the channel) is blinking in the display.

After determining the pH Value of the Sample, press the ► key again to proceed with the calibration.

A 1.25 µS/cm
A 25.00 °C
B Point1 = 7.000 pH
B pH = 7.583 pH ▲

Enter the pH value of the sample then press the [ENTER] key to start calibration.

After a successful calibration, the calibration values are taken over and stored in the cal history (Adjust), only stored in the cal history (Calibrate) or aborted.

7.4.4 mV calibration

A 1.25 µS/cm
A 25.00 °C
Calibrate Sensor
Channel B mV ▲

Enter mV Calibration mode as described in section [7.1](#).

A 1.25 µS/cm
A 25.00 °C
B Point1 = 11.06
B mV = 10.04 ▲

The user can now enter Point 1. The offset calibration factor is calculated as: Point1 + mV (measured value) and displayed on the next screen.

```

A 1.25 µS/cm
A 25.00 °C
B Point1 = 11.06
B mV = 10.04 ▲

```

Z is the newly calculated offset calibration factor. The slope calibration factor S is always 1 and does not enter the calculation.

After a successful calibration, the calibration values are taken over and stored in the cal history (Adjust), only stored in the cal history (Calibrate) or aborted.

7.5 Sensor Temperature Calibration

Enter Sensor Calibration mode as described in section 7.1 and select Temperature.

```

A 1.25 µS/cm
A 25.00 °C
Calibrate Sensor
Channel A Temperature ▲

```

7.5.1 One-Point Sensor Temperature Calibration

Select 1 point calibration. Slope or Offset can be selected with the 1 point calibration. Select Slope to recalculate the Slope factor M (Multiplier) or Offset to recalculate the offset calibration factor A (Adder).

```

A 1.25 µS/cm
A 25.00 °C
Temperature Calibration
Type = 1 point Slope ▲

```

Enter the value for Point 1 and press [ENTER].

```

A 1.25 µS/cm
A 25.00 °C
A Point1 = 25.02 °C
A T = 25.00 °C ▲

```

After a successful calibration, the calibration values are taken over and stored in the cal history (Adjust), only stored in the cal history (Calibrate) or aborted.

```

A 1.25 µS/cm
A 25.00 °C
Temp M=1.00001 A=0.00000
Save Calibration Yes ▲

```

7.5.2 Two – Point Sensor Temperature Calibration

Select 2 point as calibration Type.

```

A 1.25 µS/cm
A 25.00 °C
Temperature Calibration
Type = 2 point ▲

```

Enter the value for Point 1 and press [ENTER].

```

A 1.25 µS/cm
A 25.00 °C
A Point1 = 25.02 °C
A T = 25.00 °C ▲

```

Enter the value for Point 2 and press [ENTER].

```

A 1.25 µS/cm
A 25.00 °C
A Point2 = 50.00 °C
A T = 50.64 °C ▲

```

```

A 1.25 µS/cm
A 25.00 °C
Temp M=1.00001 A=0.00000
Save Calibration Yes ▲

```

After a successful calibration, the calibration values are taken over and stored in the cal history (Adjust), only stored in the cal history (Calibrate) or aborted.

7.6 Edit Sensor Calibration Constants (only for analog sensor)

Enter Calibration mode as described in section 7.1 and select Edit, Edit pH or Edit mV.

```

A 1.25 µS/cm
A 25.00 °C
Calibrate Sensor
Channel A Edit ▲

```

All calibration constants for the selected sensor channel are displayed. Primary measurement constants (p) are displayed on Line 3. Secondary measurement (temperature) constants (s) for the sensor are displayed on Line 4.

```

A 1.25 µS/cm
A 25.00 °C
Ap M=0.1000 A=0.0000
As M=0.1000 A=0.0000 ▲

```

The calibration constants can be changed in this menu.

```

A 1.25 µS/cm
A 25.00 °C
Save Calibration Yes
Press ENTER to Exit ▲

```

Select Yes to save the new calibration values and the successful Calibration is confirmed on the display.



NOTE: Each time a new conductivity sensor is connected to the M400 transmitter, it is necessary to enter the unique calibration constant located on the sensor label.

7.7 Sensor Verification

Enter Calibration mode as described in section 7.1. and select Verify.

```

A 1.25 µS/cm
A 25.00 °C
Calibrate Sensor
Channel A Verify ▲

```

The measured signal of the primary and the secondary measurement in electrical units are shown. The meter calibration factors are used when calculating these values.

```

A 1.25 µS/cm
A 25.00 °C
Verify Cal:Channel A
Ch A 1.820 MΩ 1.097 KΩ

```

8 Configuration

(PATH: Menu/Configure)

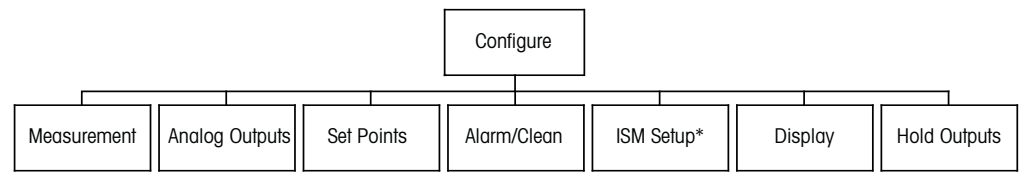

* Only available in combination with ISM sensors

8.1 Enter Configuration Mode



While in Measurement mode, press the ◀ key. Press the ▲ or ▼ key to navigate to the Configure – Menu and press [ENTER].

8.2 Measurement

(PATH: Menu/Configure/Measurement)

Enter configuration mode as described in Section 8.1.

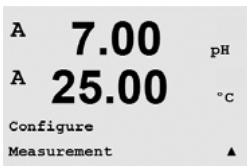

Press the [ENTER] key to select this Menu. The following sub menus can now be selected: Channel Setup, Temperature Source, Comp/pH/O₂ and Set Averaging.

8.2.1 Channel Setup

(PATH: Menu/Configure/Measurement/Channel Setup/Select Channel ISM)

Press the [ENTER] key to select the “Channel Setup” Menu.

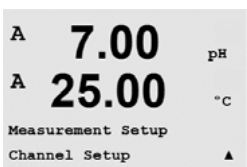

Conventional (analog) Sensor

Select Sensor Type (Analog or ISM) and press [ENTER]. Available Measurement Types are (depends on transmitter type)

Measurement parameter	Type
pH/ORP = pH or ORP	1,2,3
Cond (2) = 2 electrode conductivity	1,2,3
Cond (4) = 4 electrode conductivity	1,2,3
O ₂ hi = only Dissolved oxygen (ppm) (no gas)	2,3
O ₂ lo = only Dissolved oxygen (ppb) (no gas)	3

The 4 lines of the display can now be configured with sensor channel “A” (if analog Sensor is chosen) or “B” (if ISM Sensor is chosen) for each line of the display as well as measurements and unit multipliers. Pressing the [ENTER] key will display the selection for lines a, b, c and d.

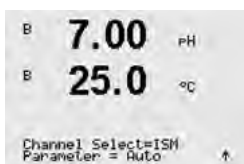

ISM (digital) Sensor

If an ISM sensor is connected, the transmitter automatically (Parameter = Auto) recognizes the type of sensor. You can also fix the transmitter to a certain measurement parameter (Parameter = pH/ORP, Cond (2), Cond(4), O₂ hi or O₂ lo), depending on the type of transmitter you have. Choose the display setting for line a, b, c, d.

Measurement parameter	Type
pH/ORP = pH or ORP	1,2,3
Cond (2) = 2 electrode conductivity*	1,2,3
Cond (4) = 4 electrode conductivity*	1,2,3
O ₂ hi = Dissolved oxygen (ppm)	2,3
O ₂ lo = Dissolved oxygen (ppb, traces*)	3
O ₂ opt hi = Dissolved oxygen (ppm) optical	2,3
O ₂ opt lo = Dissolved oxygen (ppb) optical	3

* Available as of Q4/2008

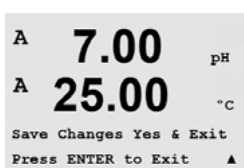

Pressing the [ENTER] key again will bring up the Save Changes dialog. Selecting No will discard the entered values and return to the measurement display screen, selecting Yes will save changes made.

8.2.2 Temperature Source (Not used with ISM Sensors)

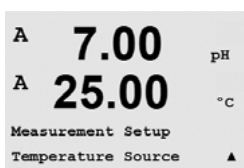

Press the [ENTER] key to select this: Menu/Configure/Measurement/Temperature Source. The following options can be chosen:

- Auto: The transmitter automatically recognizes the temperature source.
- Use NTC22K: Input will be taken from the sensor attached.
- Use Pt1000: Temperature input will be taken from the sensor attached.
- Use Pt100: Input will be taken from the sensor attached.
- Fixed = 25 °C: Allows a specific temperature value to be entered. It must be chosen when customer use pH sensor without temperature source.

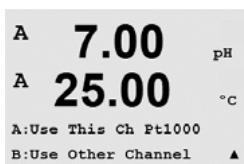

8.2.3 pH/O₂ Parameter related settings

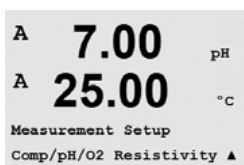

Press [ENTER] to select this: Menu/Quick Setup/Channel select ISM/Parameter. Additional measurement and calibration parameters can be set for each parameter; conductivity, pH and O₂.

For more details, please see the following explanations depending on the selected parameter.

8.2.3.1 Conductivity Temperature Compensation

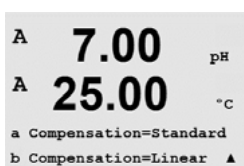

The temperature compensation mode for any of the four measurement lines can be selected. Temperature compensation should be matched to the characteristics of the application. Choices are "Standard" and "Linear". Press [ENTER] and save changes.

Standard compensation includes compensation for non-linear high purity effects as well as conventional neutral salt impurities and conforms to ASTM standards D1 125 and D5391.

```

A 7.00 pH
A 25.00 °C
c Compensation=Cation
d Compensation=Std 75°C▲

```

Linear compensation adjusts the reading by a factor expressed as a “% per °C” (deviation from 25 °C). Use only if the sample has a well-characterized linear temperature coefficient. The factory default setting is 2.0%/°C.

8.2.3.2 pH Parameters

Select pH and press [ENTER].

```

A 7.00 pH
A 25.00 °C
Measurement Setup
Comp/pH/O2 pH ▲

```

Select the **Drift control** for calibration as Auto (drift and time criteria have to be fulfilled) or Manual (The user can decide when a signal is stable enough to complete calibration) followed by the relevant buffer table for the automatic buffer recognition. If the drift rate is less than 0.4 mV over a 19 second interval then the reading is stable and the calibration is done using the last reading. If the drift criteria is not met within 300 seconds then the calibration times out and the message “Calibration Unsuccessful Press Enter to Continue” is displayed.

```

A 7.00 pH
A 25.00 °C
A:IP = 7.000 pH
B:IP = 7.000 pH ▲

```

For automatic **buffer recognition** during calibration, select the buffer solution set that will be used: Mettler-9, Mettler-10, NIST Tech, NIST Std = JIS Std, HACH, CIBA, MERCK, WTW or None. See Section 20 for buffer values. If the auto buffer feature will not be used or if the available buffers are different from those above, select None.

```

A 7.00 pH
A 25.00 °C
A:pH Buffer= Mettler-9
B:pH Buffer= Mettler-10▲

```

STC is the solution temperature coefficient in units of pH/°C referenced to 25 °C (Default = 0.000 for most applications). For pure waters, a setting of 0.016 pH/°C should be used. For low conductivity power plant samples near 9 pH, a setting of 0.033 pH/°C should be used. These positive coefficients compensate for the negative temperature influence on the pH of these samples.

```

A 7.00 pH
A 25.00 °C
A:Drift Control = Auto
B:Drift Control =Manual▲

```

IP is the isothermal point value (Default = 7.000 for most applications). For specific compensation requirements or non standard inner buffer value, this value can be changed.

The option to enter a **fixed Calibration Temperature** is given. “Fixed” allows a specific temperature value to be entered. Selecting “No” means the Temperature configured under 8.2.2 will be used for the Calibration.

```

A 7.00 pH
A 25.00 °C
A:Fix CalTemp No
B:Fix CalTemp Yes 25.00▲

```

Pressing [ENTER] again will bring up the Save Changes dialog. Selecting No will discard the entered values and return to the measurement display screen, selecting Yes will save changes made.

```

A 7.00 pH
A 25.00 °C
A:STC = 0.000 pH/°C
B:STC = 0.000 pH/°C ▲

```

8.2.3.3 Dissolved Oxygen Parameters

Select O₂ and press [ENTER]

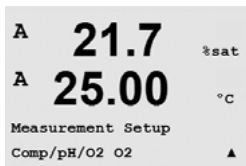

Enter the Atmospheric pressure. The default value for AtmPres is 759.8 and the default unit is mmHg.

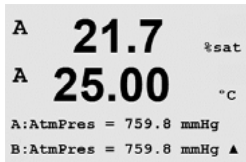

Enter the Process Pressure. The units for process pressure and atmospheric pressure do not have to be the same.



The salinity of the measured solution and the relative humidity of the calibration gas can also be entered. The allowed values for Relative Humidity are in the range 0.00 to 100%. When no humidity measurement is available, use 50% (default value).

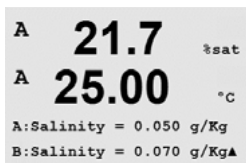

Pressing the [ENTER] key again will bring up the Save Changes dialog. Selecting No will discard the entered values and return to the measurement display screen, selecting Yes will save changes made.

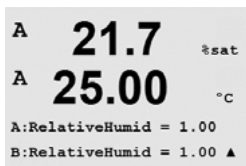

8.2.4 Set Averaging

Press the [ENTER] key to select this: Menu/Configure/Measurement/Set Averaging. The averaging method (noise filter) for each measurement line can now be selected. The options are Special (Default), None, Low, Medium and High:

- None = no averaging or filtering
- Low = equivalent to a 3 point moving average
- Medium = equivalent to a 6 point moving average
- High = equivalent to a 10 point moving average
- Special = averaging depending on signal change (normally High averaging but Low averaging for large changes in input signal)

Pressing the [ENTER] key again will bring up the Save Changes dialog. Selecting No will discard the entered values and return to the measurement display screen, selecting Yes will save changes made.

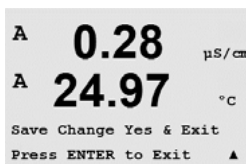
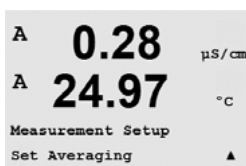

8.3 Analog Outputs

(PATH: Menu/Configure/Analog Outputs)

Enter configuration mode as described in Section 8.2.

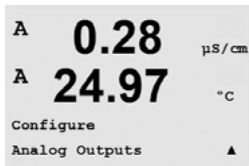

Press the [ENTER] key to select this Menu, which lets you configure the 4 Analog Outputs. Once analog outputs have been selected, use the ◀ and ▶ buttons to navigate between configurable parameters. Once a parameter is selected, its setting can be selected per the following table:

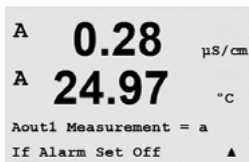

When an Alarm Value is selected, the analog output will go to this value if any alarm condition occurs.

Parameter	Selectable Values
Aout:	1, 2, 3 or 4 (default is 1)
Measurement:	a, b, c, d or blank (none) (default is blank)
Alarm Value:	3.6 mA, 22.0 mA or Off (default is off)

The Aout type can be Normal, Bi-Linear, Auto-Range or Logarithmic. The range can be 4–20mA or 0–20mA. Normal provides linear scaling between the minimum and maximum scaling limits and is the default setting. Bi-Linear will also prompt for a scaling value for the mid-point of the signal and allows two different linear segments between the minimum and maximum scaling limits.

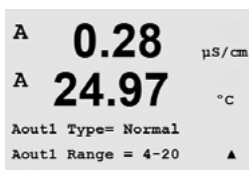

Enter the minimum and maximum Value of Aout.

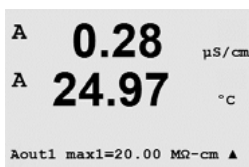
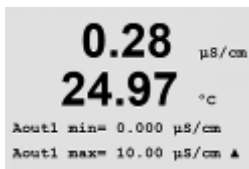

If Auto-Range was selected then Aout max1 can be configured. Aout max1 is the maximum value for the first range on Auto-Range. The maximum value for the second range on Auto-Range was set in the previous menu. If Logarithmic Range was selected, it will also prompt for the number of decades as "Aout1 # of Decades =2".



The value for the Hold mode can be configured to hold the Last value or can be set to a Fixed value.

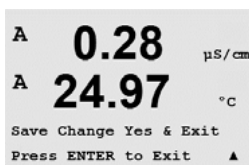

Pressing the [ENTER] key again will bring up the Save Changes dialog. Selecting No will discard the entered values and return to the measurement display screen, selecting Yes will save changes made.

8.4 Setpoints

(PATH: Menu/Configure/Setpoints)

Enter configuration mode as described in Section 8.1.

Press the [ENTER] key to select this Menu.

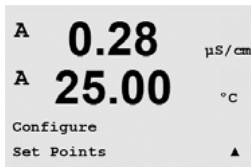

Up to 6 Setpoints can be configured on any of the measurements (a thru d). The possible Setpoint types are Off, High, Low, Outside and Between.

An "Outside" Setpoint will cause an alarm condition whenever the measurement goes above its high limit or below its low limit. A "Between" Setpoint will cause an alarm condition to occur whenever the measurement is between its high and low limits.

Enter the desired value(s) for the Setpoint and press [ENTER]

This screen provides the option to configure a setpoint to be active on an over range condition. Select the setpoint and "Yes" or "No". Select the desired relay that will activate when the setpoint alarm condition is reached.



Over Range

Once configured, the selected relay will be activated if a sensor over-range condition is detected on the assigned input channel.

Delay

Enter the delay time in seconds. A time delay requires the setpoint to be exceeded continuously for the specified length of time before activating the relay. If the condition disappears before the delay period is over, the relay will not be activated.



Hysteresis

Enter the hysteresis as a percentage-value. A hysteresis value requires the measurement to return within the setpoint value by a specified percentage before the relay is deactivated.

For a high setpoint, the measurement must decrease more than the indicated percentage below the setpoint value before the relay is deactivated. With a low setpoint, the measurement must rise at least this percentage above the setpoint value before the relay is deactivated. For example, with a high setpoint of 100, when this value is exceeded, the measurement must fall below 90 before the relay is deactivated.

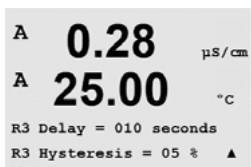

Hold

Enter the Relay Hold Status of "Last", "On" or "Off". This is the state the Relay will go to during a Hold status.

State

Relay contacts are in normal state until the associated setpoint is exceeded, then the relay is activated and the contact states change.

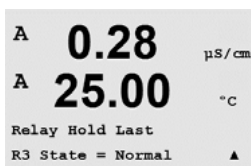

Select "Inverted" to reverse the normal operating state of the relay (i.e. Normally open contacts are in a closed state, and normally closed contacts are in an open state, until the setpoint is exceeded). "Inverted" relay operation is functional when power is applied to the M400 transmitter. Relay No 2 always operates inverted. All other relays can be configured.

Pressing the [ENTER] key again will bring up the Save Changes dialog. Selecting No will discard the entered values and return to the measurement display screen, selecting Yes will save changes made.

8.5 Alarm/Clean

(PATH: Menu/Configure/Alarm/Clean)

Enter configuration mode as described in Section 8.1.

This Menu allows the configuration of Alarm and Clean functionality.

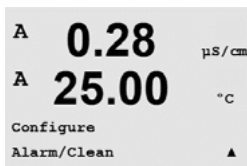

8.5.1 Alarm

To select "Setup Alarm", press the ▲ or ▼ key so that "Alarm" is flashing.

Using the ◀ and ▶ buttons, navigate to "Use Relay #". Using the ▲ or ▼ keys, select a relay to be used for the Alarm and press [ENTER].

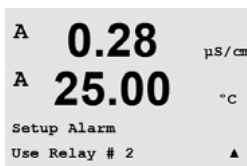

One of the following events may be alarmed:

1. Power Failure
2. Software Failure
3. Rg Diagnostics – pH glass membrane resistance (only for pH sensors)
4. Rr Diagnostics – pH reference resistance (only for pH sensors)
5. Cond cell open (only for cond sensors)
6. Cond cell shorted (only for cond sensors)
7. Channel B disconnected (only for ISM sensors)
8. Shaft Error (only for optical Sensors)
9. Signal Error (only for optical Sensors)
10. Hardware Error (only for optical Sensors)

Detailed information about error messages for an optical sensor you find in the Menu/Service/Diagnostics/O₂ optical.

If any of these are set to Yes, an alarm signal will be initiated, the selected relay will be activated, and an alarm message will be recorded if:

1. there is a power failure or power cycling
2. the software watchdog performs a reset
3. Rg is out of tolerance – for example, broken measuring electrode (only for pH sensors)
4. Rr is out of tolerance – for example, coated or depleted reference electrode (only for pH sensors)
5. If the conductivity sensor is on air (for example in an empty pipe)
6. If the conductivity sensor has a short cut
7. If no sensor is connected on channel B (only for ISM sensors)

For 1 and 2 the alarm indicator will be turned off when the alarm message is cleared. It will reappear if the power is constantly cycling or if the watchdog is repeatedly resetting the system.

Only for pH sensors

For 3 and 4 the alarm indicator will go off if the message is cleared and the sensor has been replaced or repaired so that the Rg and Rr values are within specification. If the Rg or Rr message is cleared and Rg or Rr is still out of tolerance then the alarm will stay on and the message will reappear. The Rg and Rr alarm can be turned off by going into this menu and setting Rg Diagnostics and/or Rr Diagnostics to No. The message can then be cleared and the alarm indicator will be off even though Rg or Rr is out of tolerance.

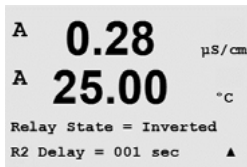

Each Alarm Relay can be configured in either a Normal or Inverted state. In addition, a Delay for the activation can be set. For more information, refer to Section 8.4.

If power failure is turned on, only inverted state is possible and cannot be changed.

Pressing the [ENTER] key again will bring up the Save Changes dialog. Selecting No will discard the entered values, selecting Yes will make the entered values the current ones.

8.5.2 Clean



Configure the Relay to be used for the cleaning cycle. The Default value is Relay 1.

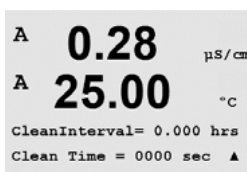

The Cleaning Interval can be set from 0.000 to 999.9 hours. Setting it to 0 turns the clean cycle off. The cleaning time can be 0 to 9999 seconds and must be smaller than the Cleaning Interval.

Select the desired Relay state: Normal or Inverted.

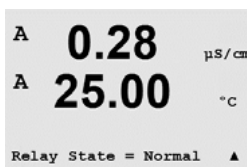

Pressing the [ENTER] key again will bring up the Save Changes dialog. Selecting No will discard the entered values and return to the measurement display screen, selecting Yes will save changes made.

8.6 ISM Set up (only available if an ISM sensor is connected)

8.6.1 Sensor Monitoring



The sensor monitoring options can be turned on or off and every Alarm can be assigned to a certain output relays. The following options are possible:

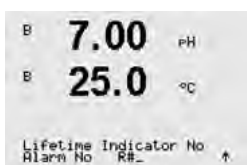

Lifetime indicator: The dynamic lifetime indication allows an estimation, when the sensor (pH) or inner body (DO) or OptoCap is at the end of his lifetime, based on the actual stress he is exposed to. The sensor permanently takes the averaged stress of the past days into consideration and is able to increase/decrease the lifetime accordingly.

Lifetime Indicator	YES/NO
Alarm	YES/NO R# choose relay

The following parameters affect the lifetime indicator:

- | | |
|---------------------------------|---|
| Dynamic parameters: | Static parameters: |
| – Temperature | – Calibration history |
| – pH or oxygen value | – Zero and Slope |
| – Glass impedance (only pH) | – Phase 0 and Phase 100 (only optical DO) |
| – Reference impedance (only pH) | – Illumination time (only optical DO) |
| | – CIP/SIP/Autoclaving cycles |

The sensor keeps the information stored in the built in electronics and can be retrieved via a transmitter or the ISense asset management suite.

The alarm will be reseted if the Lifetime Indicator is not 0 days anymore (e.g. after connecting a new sensor or changes on the measurement conditions).

For amperometric Oxygen sensors, the lifetime indicator is related to the inner-body of the sensor. After exchanging the inner-body, reset the lifetime indicator in the ISM Setup menu (menu Configure).

For optical DO sensors the lifetime indicator is related to the OptoCap. After exchanging the OptoCap, reset the lifetime indicator in the ISM Setup menu (menu Configure).

If the Lifetime Indicator is turned on, the value will be automatically shown in the display on line 3.



Adaptive Cal Timer: This timer estimates when the next calibration should be performed to keep the best possible measurement performance. The timer is influenced by significant changes on the DLI parameters.

Adaptive Cal Timer YES/NO
 Alarm YES/NO R# choose relay

The alarm will be reseted after a successful calibration.
 If the Adaptive Cal Timer is turned on, the value will be automatically shown in the display on line 4.



NOTE: The recommended initial value for the calibration interval will be uploaded from the sensor to the transmitter and can be adapted according to the application experience (menu Configure/ISM Setup/Sensor monitoring).



Time to Maintenance (not for optical sensors): This timer estimates when the next cleaning cycle should be performed to keep the best possible measurement performance. The timer is influenced by significant changes on the DLI parameters.

Time to Maintenance YES/NO
 Alarm YES/NO R# choose relay

The alarm needs to be reseted in the menu "ISM Setup". For oxygen sensors, the time to maintenance indicates a maintenance cycle for the membrane and electrolyte.



NOTE: The recommended initial value for the maintenance interval will be uploaded from the sensor to the transmitter and can be adapted according to the application experience (menu Configure/ISM Setup/Sensor monitoring).

8.6.2 CIP Cycle Limit

Please activate the function ISM (see chapter 8.2.1) configuring the CIP cycle limit. The CIP cycle limit counts the number of CIP cycles if the limit (user defined) is reached, an alarm can be indicated and set to a certain output relays. The following options are possible:

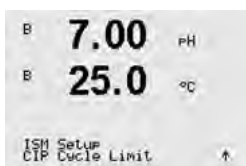

CIP Max 000
 Alarm YES/NO R# choose relay

If the Max setting is on 000, the counter functionality is turned off. The alarm will be reseted after exchanging the sensor. For oxygen sensors, the counter can be reseted in the ISM Setup menu (menu Configure)



CIP characteristics: CIP Cycles will be automatically recognized by the sensor. Since CIP cycles will vary in intensity (duration and temperature) for each application the algorithm of the counter recognizes an increase of the measurement temperature above a certain level (70 °C for CIP). If the temperature does not decrease below (60 °C for CIP) within the next 5 minutes after the first temperature was reached, the counter in question will be incremented by one and also locked for the next two hours. In the case the CIP would last longer than two hours the counter would be incremented by one once more.

8.6.3 SIP Cycle Limit

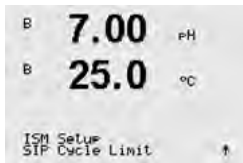

The SIP cycle limit counts the number of SIP cycles if the limit (user defined) is reached, an alarm can be indicated and set to a certain output relays. The following options are possible:

SIP Max 000
Alarm YES/NO R# choose relay

If the Max setting is on 000, the counter functionality is turned off. The alarm will be reseted after exchanging the sensor. For oxygen sensors, the counter can be reseted in the ISM Setup menu (menu Configure).

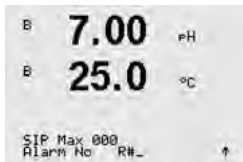

SIP characteristics: SIP Cycles will be automatically recognized by the sensor. Since SIP cycles will vary in intensity (duration and temperature) for each application the algorithm of the counter recognizes an increase of the measurement temperature above a certain level (110 °C for SIP). If the temperature does not decrease below (100 °C for SIP) within the next 5 minutes after the first temperature was reached, the counter in question will be incremented by one and also locked for the next two hours. In the case the SIP would last longer than two hours the counter would be incremented by one once more.

8.6.4 Autoclaving Cycle Limit

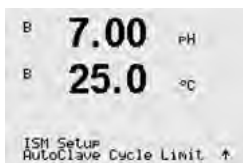

The Autoclaving cycle limit counts the number of Autoclaving cycles if the limit (user defined) is reached, an alarm can be indicated and set to a certain output relays. The following options are possible:

AutoClave Max 000
Alarm YES/NO R# choose relay

If the Max setting is on 000, the counter functionality is turned off. The alarm will be reseted after exchanging the sensor. For oxygen sensors, the counter can be reseted in the ISM Setup menu (menu Configure).



Autoclave characteristics: Since during the Autoclaving cycle the sensor is not connected to the transmitter, you will be asked after every Sensor connection, whether the sensor was autoclaved or not. According to your selection, the counter will be incremented or not.

8.6.5 Reset ISM Counter/Timer

This menu allows resetting counter and timer functions which cannot be reseted automatically. The adaptive calibration timer will be reseted after a successful adjustment or calibration.

for pH sensors:

Reset Maintenance Timer Yes/No

After a manual maintenance cycle on the sensor, this timer needs to be reseted.

for oxygen sensors:

Reset Maintenance Timer Yes/No

After a manual maintenance cycle on the sensor, this timer needs to be reseted.

Reset Lifetime Indicator Yes/No

After exchanging the inner-body of the sensor, this timer needs to be reseted.

Reset CIP counter Yes/No

Reset SIP counter Yes/No

Reset Autoclaving counter Yes/No

After a manual maintenance cycle on the sensor, this timer needs to be reseted

8.7 Display

(PATH: Menu/Configure/Display)

Enter configuration mode as described in Section 8.1.

This Menu allows for the configuration of the values to be displayed and also the configuration of the Display itself.

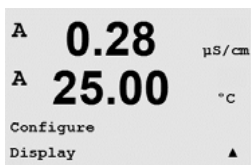

8.7.1 Measurement

The Display has 4 lines. Line 1 on top and Line 4 on the bottom.

Select the values (Measurement a, b, c or d) to be displayed on each line of the display.

The selection of the values for a, b, c, d needs to be done under Configuration/Measurement/Channel Setup.

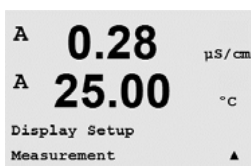

Select the "Error Display" mode. If this is set to "On" when an alarm has occurred, the message "Failure – Press Enter" will be displayed on Line 4 when an alarm occurs in the normal Measurement mode.

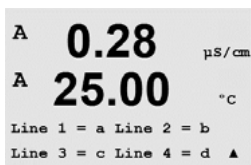

Pressing the [ENTER] key again will bring up the Save Changes dialog. Selecting No will discard the entered values, selecting Yes will make the entered values the current ones.



8.7.2 Resolution

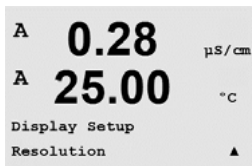

This menu allows the setting of the resolution of each displayed value. The accuracy of the measurement is not effected by this setting.

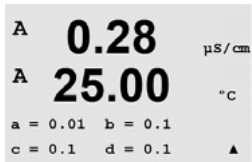

Possible settings are 1, 0.1, 0.01, 0.001 or Auto.

Pressing the [ENTER] key will bring up the Save Changes dialog.

8.7.3 Backlight

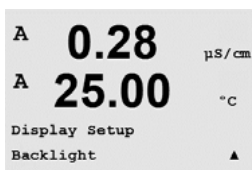

This Menu allows the setting of the back light options of the display.

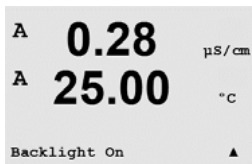

Possible settings are On, On 50% or Auto Off 50%. If Auto Off 50% is selected then the backlight will go to 50% after 4 minutes with no keypad activity. The backlight will automatically come back on if a key is pressed.

Pressing the [ENTER] key Will bring up the Save Changes dialog.

8.7.4 Name

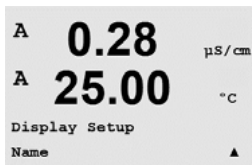

This menu allows for the configuration of an alpha-numeric name which is displayed in the first 9 characters on Lines 3 and 4 of the Display. The default is nothing (blank).

If a name is entered on line 3 and/or 4 a measurement can be still displayed on the same line.



Use the ◀ and ▶ keys to navigate between digits to be altered. Using the ▲ and ▼ keys to change the character to be displayed. Once all digits of both display channels have been entered, press [ENTER] to bring up the Save Changes dialog.



The resulting display in the measurement mode appears on Lines 3 and 4 ahead of the measurements.

8.7.5 ISM Sensor Monitoring (available when ISM sensor connected)

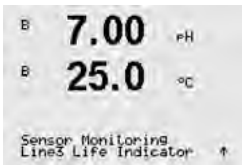

The sensor monitoring allows you to display the sensor monitoring details on line 3 and 4 in the display. The following options are possible:

- Line 3 Off/Time Indicator/Time to Maint/Adapt Cal Timer
- Line 4 Off/Time Indicator/Time to Maint/Adapt Cal Timer

8.8 Hold Analog Outputs

(PATH: Menu/Configure/Hold Outputs)

Enter configuration mode as described in Section 8.1.

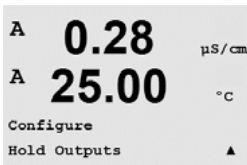

The **“Hold outputs”** function applies during the calibration process. If set “Hold outputs” to Yes, during calibration process the analog output, the output relay and USB output will be at hold state. The hold state depends on the setting. For the possible hold settings, see the list below. The following options are possible:

Hold Outputs? Yes/No

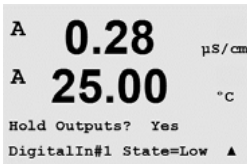

The **“DigitalIn”** function applies all the time. As soon as a signal is active on the digital input the transmitter goes to hold mode and the values on the analog output, the output relays and the USB output will be at hold state.

DigitalIn1/2 State = On/Low/High



NOTE: DigitalIn1 is to hold channel A (conventional sensor)
DigitalIn2 is to hold channel B (ISM sensor)

Possible Hold states:

Output relays:	On/Off	(Configuration/Set point)
Analog Output:	Last/Fixed	(Configuration/Analog output)
USB:	Last/Off	(System/USB)
PID relay	Last/Off	(PID setup/Mode)
PID analog	Last/Off	(PID setup/Mode)

9 System

(PATH: Menu/System)

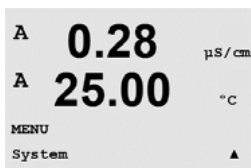
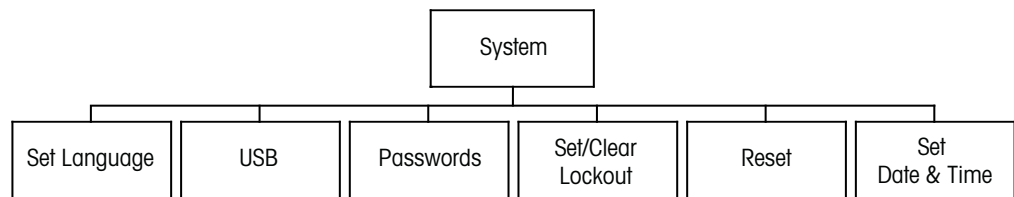

While in Measurement mode press the ◀ key. Press the ▼ or ▲ key to navigate to “System” – Menu and press [ENTER].

9.1 Set Language

(PATH: Menu/System/Set Language)

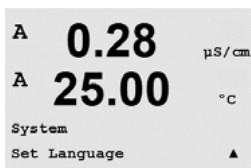

This Menu allows the configuration of the Display language.

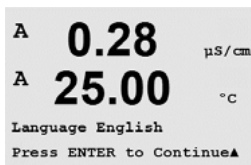

The following selections are possible:
English, French, German, Italian, Spanish, Portuguese, Russian or Japanese (Katakana).

Pressing the [ENTER] key will bring up the Save Changes dialog.

9.2 USB

(PATH: Menu/System/USB)

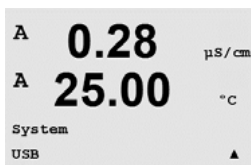

This menu allows configuration of the USB hold function.

USB Hold may be set to either Off or Last Values. An external host device may poll the M400 for data. If the USB Hold is set to Off, current values are returned. If the USB Hold is set to Last Values, the values present at the time the hold condition was established are returned.



Press [ENTER] to bring up the Save Changes dialog.

9.3 Passwords

(PATH: Menu/System/Passwords)

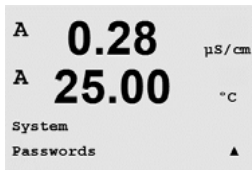

This Menu allows for the configuration of Operator and Administrator Passwords, as well as setting up a List of allowed Menus for the Operator. The Administrator has rights to access all Menus. All default passwords for new transmitters are "00000".

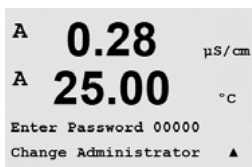

The Passwords Menu is protected: Enter the Administrator Password to enter the Menu.

9.3.1 Changing Passwords

See Section 9.3 on how to enter the Passwords Menu. Select Change Administrator or Change Operator and set the new Password.

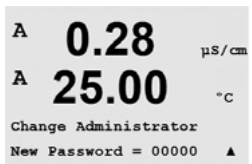

Press the [ENTER] key and confirm the new password. Press [ENTER] again to bring up the Save Changed dialog.

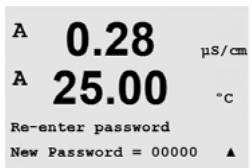

9.3.2 Configuring Menu Access for Operator

See 9.3 on how to enter the Passwords Menu. Select Configure Operator to configure the Access list for the Operator. It is possible to assign/deny rights to the following Menus: Cal Key, Quick Setup, Configuration, System, PID Setup and Service.

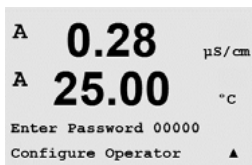

Choose either Yes or No to give/deny access to the above Menus and press [ENTER] to advance to the next items. Pressing the [ENTER] key after configuring all menus will bring up the Save Changes dialog. Selecting No will discard the entered values, selecting Yes will make the entered values the current ones.

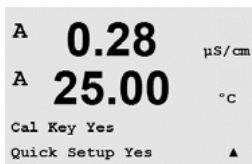

9.4 Set/Clear Lockout

(PATH: Menu/System/Set/Clear Lockout)

This menu enables/disables the Lockout functionality of the transmitter. The user will be asked for a password before being allowed into any menus if the Lockout functionality is enabled.

```

A 0.28 µS/cm
A 25.00 °C
System
Set/Clear Lockout ▲
  
```

```

A 0.28 µS/cm
A 25.00 °C
Password = 00000
Enable Lockout = Yes ▲
  
```

The Lockout – Menu is protected: Enter the Administrator or Operator Password and select YES to enable or NO to disable the Lockout functionality. Pressing the [ENTER] key after the selection will bring up the Save Changes dialog. Selecting No will discard the entered value, selecting Yes will make the entered value the current one.

9.5 Reset

(PATH: Menu/System/Reset)

This Menu allows access to the following options:
Reset System, Reset Meter Cal, Reset Analog Cal.

```

A 0.28 µS/cm
A 25.00 °C
System
Reset ▲
  
```

9.5.1 Reset System

This Menu allows the reset of the meter to the factory default settings (Setpoints off, analog outputs off, etc.). The meter calibration and the analog output calibration are not affected.

```

A 0.28 µS/cm
A 25.00 °C
Reset System ? Yes
Press ENTER to Continue▲
  
```

```

A 0.28 µS/cm
A 25.00 °C
Reset System
Are you sure? Yes ▲
  
```

Pressing the [ENTER] key after the selection will bring up a confirmation screen. Selecting No will return the user to the Measurement mode with no changes. Selecting Yes will reset the meter.

9.5.2 Reset Meter Calibration

This Menu allows the reset of the meter's calibration factors to the last factory calibration values.

```

A 0.28 µS/cm
A 25.00 °C
Reset Meter Cal ? Yes
Press ENTER to Continue▲
  
```

```

A 0.28 µS/cm
A 25.00 °C
Reset Meter Calibration
Are you sure? Yes ▲
  
```

Pressing the [ENTER] key after the selection will bring up a confirmation screen. Selecting No will return the user to the Measurement mode with no changes. Selecting Yes will reset the meter calibration factors.

9.5.3 Reset Analog Calibration

A 0.28 $\mu\text{S}/\text{cm}$
 A 25.00 $^{\circ}\text{C}$
 Reset Analog Cal? Yes
 Press ENTER to Continue▲

This Menu allows reset of the Analog Output calibration factors to the last factory calibration values.

A 0.28 $\mu\text{S}/\text{cm}$
 A 25.00 $^{\circ}\text{C}$
 Reset Analog Calibration
 Are you sure? Yes ▲

Pressing the [ENTER] key after the selection will bring up a confirmation screen. Selecting No will return the user to the Measurement mode with no changes. Selecting Yes will reset the Analog Output calibration.

9.6 Set Date & Time

B 7.00 pH
 B 25.0 $^{\circ}\text{C}$
 System
 Set Date&Time ▲

Please enter the actual date and time. The following options are possible. This function is automatically activated at every power-up.

Date (YY-MM-DD):

Time (HH:MM:SS):

10 PID Setup

(PATH: Menu/PID Setup)

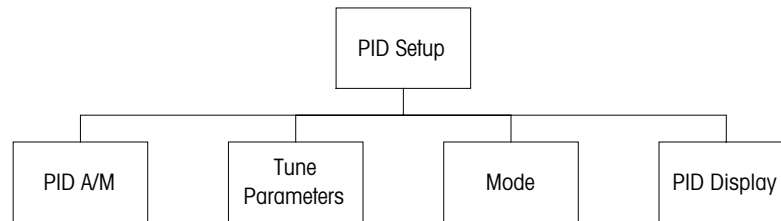

PID control is proportional, integral and derivative control action that can provide smooth regulation of a process. Before configuring the transmitter, the following process characteristics must be identified.

Identify the **control direction** of the process

– **Conductivity:**

Dilution – direct acting where increasing measurement produces increasing control output such as controlling the feed of low conductivity diluting water to rinse tanks, cooling towers or boilers

Concentrating – reverse acting where increasing measurement produces decreasing control output, such as controlling chemical feed to attain a desired concentration

– **Dissolved Oxygen:**

Deaeration – direct acting where increasing DO concentration produces increasing control output such as controlling the feed of a reducing agent to remove oxygen from boiler feedwater

Aeration – reverse acting where increasing DO concentration produces decreasing control output, such as controlling an aerator blower speed to maintain a desired DO concentration in fermentation or wastewater treatment

– **pH/ORP:**

Acid feed only – direct acting where increasing pH produces increasing control output, also for ORP reducing reagent feed

Base feed only – reverse acting where increasing pH produces decreasing control output, also for ORP oxidizing reagent feed

Both acid and base feed – direct and reverse acting

Identify the **control output type** based on the control device to be used:

Pulse Frequency – used with pulse input metering pump

Pulse Length – used with solenoid valve

Analog – used with current input device such as electric drive unit, analog input metering pump or current-to-pneumatic (I/P) converter for pneumatic control valve

Default control settings provide linear control, which is appropriate for conductivity, dissolved oxygen. Therefore, when configuring PID for these parameters (or simple pH control) ignore settings of deadband and corner points in the Tuning Parameter section below. The non-linear control settings are used for more difficult pH/ORP control situations.

If desired, identify the non-linearity of the pH/ORP process. Improved control can be obtained if the non-linearity is accommodated with an opposing non-linearity in the controller. A titration curve (graph of pH or ORP vs. reagent volume) made on a process sample provides the best information. There is often a very high process gain or sensitivity near the setpoint and decreasing gain further away from the setpoint. To counteract this, the instrument allows for adjustable non-linear control with settings of a deadband around the setpoint, corner points

further out and proportional limits at the ends of control as shown in the figure below. Determine the appropriate settings for each of these control parameters based on the shape of the pH process titration curve.

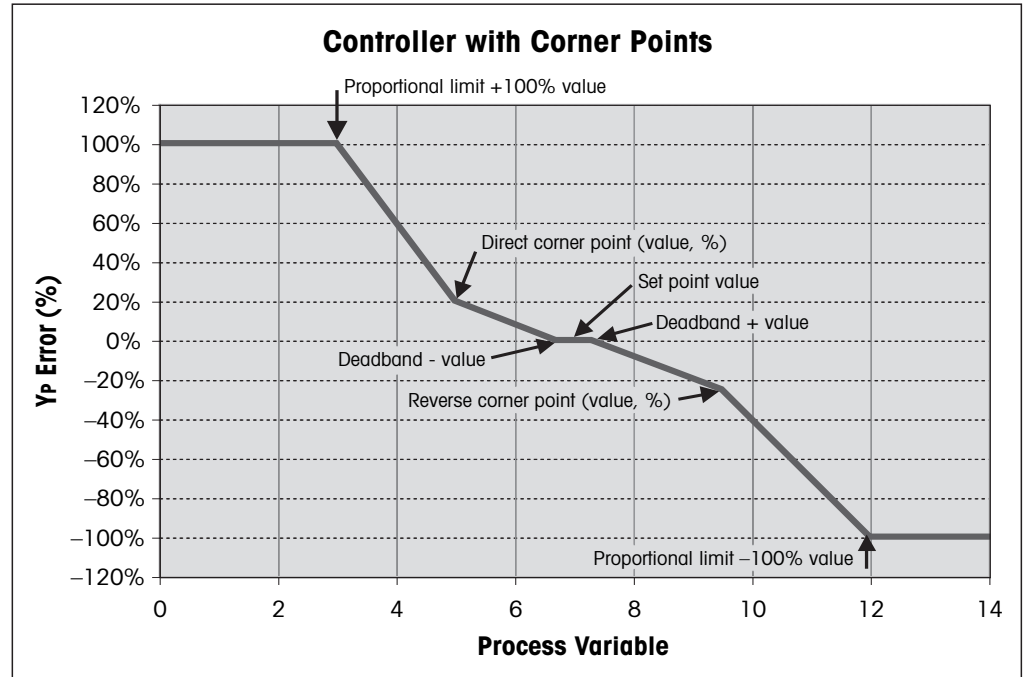

10.1 Enter PID Setup

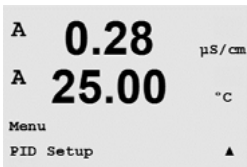

While in Measurement mode press the ◀ key. Press the ▲ or ▼ key to navigate to the PID Setup – Menu and press [ENTER].

10.2 PID Auto/Manual

(PATH: MENU/PID Setup/PID A/M)



This menu allows selection of Automatic or Manual operation. Select Auto or Manual operation. Pressing the [ENTER] key will bring up the Save Changes dialog.

10.3 Mode

(PATH: MENU/PID Setup/Mode)

This menu contains the selection of control modes using relays or analog outputs. Press [ENTER].

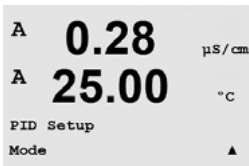

10.3.1 PID Mode

This menu assigns a relay or analog output for PID control action as well as details of their operation. Based on the control device being used, select one of the following three paragraphs for use with solenoid valve, pulse input metering pump or analog control.

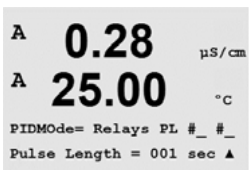

Pulse Length – If using a solenoid valve, select “Relays” and “PL”, Pulse Length. Choose the first relay position as #3 (recommended) and/or the second relay position as #4 (recommended) as well as the Pulse Length (PL) according to the table below. A longer pulse length will reduce wear on the solenoid valve. The % “on” time in the cycle is proportional to the control output.



NOTE: All relays from #1 to #6 can be used for the controlling function.

	1 st Relay Position (#3)	2 nd Relay Position (#4)	Pulse Length (PL)
Conductivity	Controlling concentrating reagent feed	Controlling dilution water	Short (PL) provides more uniform feed. Suggested start point = 30 sec
pH/ORP	Feeding base	Feeding acid	Reagent addition cycle: short PL provides more uniform addition of reagent. Suggested start point = 10 sec
Dissolved Oxygen	Reverse control action	Direct acting control action	Feed cycle time: short PL provides more uniform feed. Suggested start point = 30 sec

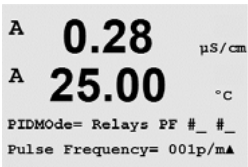

Pulse Frequency – If using a pulse input metering pump, select “Relays” and “PF”, Pulse Frequency. Choose the first relay position as #3 and/or the second relay position as #4 according to the table below. Set the pulse frequency to the maximum frequency allowed for the particular pump being used, typically 60 to 100 pulses/minute. Control action will produce this frequency at 100% output.

NOTE: All relays from #1 to #6 can be used for the controlling function.

CAUTION: Setting the Pulse Frequency too high may cause the pump to overheat.

	1 st Relay Position = #3	2 nd Relay Position = #4	Pulse Frequency (PF)
Conductivity	Controlling concentrating chemical feed	Controlling dilution water	Max allowed for the pump used (typically 60–100)
pH/ORP	Feeding base	Feeding acid	Max allowed for the pump used (typically 60–100)
Dissolved Oxygen	Reverse control action	Direct acting control action	Max allowed for the pump used (typically 60–100)

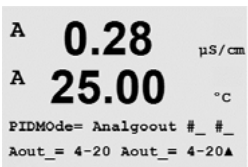

Analog – If using Analog control, change “Relays” to “Analogout” using up/down arrow keys. Choose the first Analogout position as #1 and/or the second Analogout position as #2 according to the table below. Select the analog output current range required by the control device, 4–20 or 0–20 mA. Press [ENTER].

	1 st Analogout Position = #1	2 nd Analogout Position = #2
Conductivity	Controlling concentrating chemical feed	Controlling dilution water
pH/ORP	Feeding base	Feeding acid
Dissolved Oxygen	Reverse control action	Direct acting control action

10.4 Tune Parameters

(PATH: MENU/PID Setup/Tune Parameters)

This menu assigns control to a measurement and sets the setpoint, tuning parameters and non-linear functions of the controller through a series of screens.



10.4.1 PID Assignment & Tuning

Assign the measurement, a, b, c, or d to be controlled after “PID on_”. Set the Gain (unitless), Integral or Reset time Tr (minutes) and Rate or Derivative time Td (minutes) needed for control. Press [ENTER]. Gain, Reset and Rate are later adjusted by trial and error based on process response. Always begin with Td at zero.

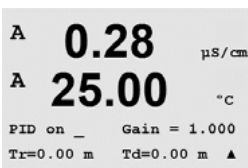

10.4.2 Setpoint & Deadband

```

A 0.28 µS/cm
A 25.00 °C
SetPoint = 0.000 _
Dead Band= +/-0.000 _ ▲

```

Enter the desired setpoint value and the deadband around the setpoint, where no proportional control action will take place. Be sure to include the units multiplier μ or m for conductivity. Press [ENTER].

10.4.3 Proportional Limits

```

A 0.28 µS/cm
A 25.00 °C
Prop Limit Low 0.000 _
Prop Limit High 0.000 _▲

```

Enter the low and high proportional limits – the range over which control action is required. Be sure to include the units multiplier μ or m for conductivity. Press [ENTER].

10.4.4 Corner Points

```

A 0.28 µS/cm
A 25.00 °C
Corner Low 0.000_ 1.000
CornerHigh 0.000_ -1.00▲

```

Enter the low and high corner points in conductivity, pH, dissolved oxygen units and the respective output values from -1 to $+1$, shown in the figure as -100 to $+100\%$. Press [ENTER].

10.5 PID Display

(PATH: Menu/PID Setup/PID Display Setup)

```

A 0.28 µS/cm
A 25.00 °C
PID Setup
PID Display Setup ▲

```

This screen enables display of PID control status in the normal measurement mode.

```

A 0.28 µS/cm
A 25.00 °C
PID Display Yes ▲

```

When PID Display is selected, the status (Man or Auto) and control output (%) will be displayed on the bottom line. If controlling pH, the reagent will also be displayed. In addition, for the display to be enabled, a measurement must be assigned under Tune Parameters and a relay or analog output must be assigned under Mode.

```

A 0.28 µS/cm
A 25.00 °C
B 7.00 pH
Man Ctrl Out 0.0%

```

In Manual, the control output may be adjusted with the up and down arrow keys. (The "Info" key function is not available in Manual.)

11 Service

(PATH: Menu/Service)

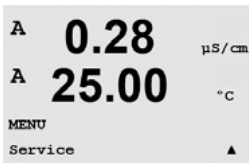
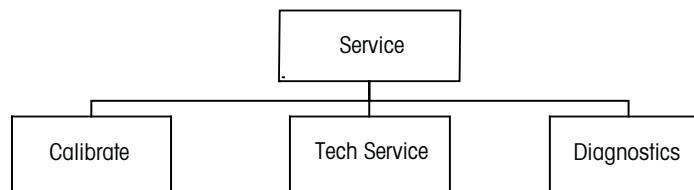

While in Measurement mode press the ◀ key. Press the ▲ or ▼ key to navigate to the “Service” Menu and press [ENTER]. The available system configuration options are detailed below

11.1 Diagnostics

(PATH: Menu/Service/Diagnostics)

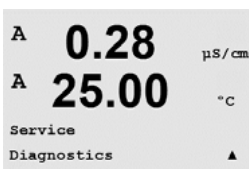

This Menu is a valuable tool for troubleshooting and provides diagnostic functionality for the following items: Model/Software Revision, Digital Input, Display, Keypad, Memory, Set Relays, Read Relays, Set Analog Outputs, Read Analog Outputs.

11.1.1 Model/Software Revision

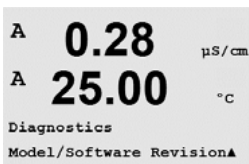

Essential information for every Service call is the model and software revision number. This Menu shows the transmitter part number, serial number and software version number. Press [ENTER] to exit from this display.

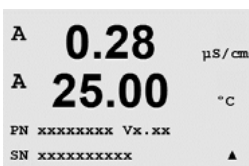

11.1.2 Digital Input

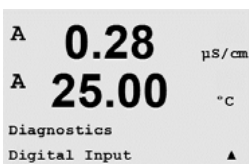

The digital Input menu shows the state of the digital inputs. Press [ENTER] to exit from this display.

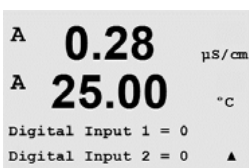

11.1.3 Display

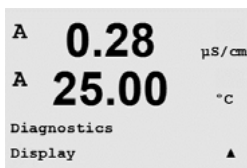

All pixels of the display will be lit for 15 seconds to allow troubleshooting of the display. After 15 seconds the transmitter will return to the normal Measuring mode or press [ENTER] to exit sooner.

11.1.4 Keypad

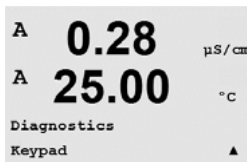

For keypad diagnostics, the display will indicate which key is pressed. Pressing [ENTER] will return the transmitter to the normal Measuring mode.

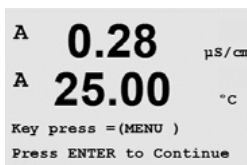

11.1.5 Memory

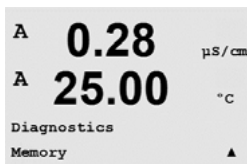

If Memory is selected then the transmitter will perform a RAM and ROM memory test. Test patterns will be written to and read from all RAM memory locations. The ROM checksum will be recalculated and compared to the value stored in the ROM.

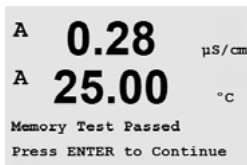

11.1.6 Set Relay

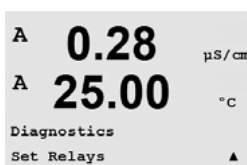

The Set Relays diagnostic menu allows for the activation/deactivation of each Relay. To access relays 5 and 6, press [ENTER].

0 = Normal (normally open contacts are open)
 1 = Inverted (normally open contacts are closed)

Press [ENTER] to return to Measurement mode.

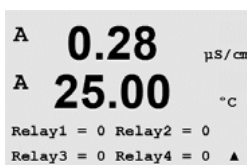

11.1.7 Read Relays

The Read Relays diagnostic menu shows the state of each Relay as defined below. To display Relays 5 and 6, press [ENTER]. Press [ENTER] again to exit from this display.

0 = Normal
1 = Inverted.

```
A 0.28  μS/cm
A 25.00 °C
Diagnostics
Read Relays ▲
```

```
A 0.28  μS/cm
A 25.00 °C
Relay1 = 0 Relay2 = 0
Relay3 = 0 Relay4 = 0
```

11.1.8 Set Analog Outputs

This menu enables the user to set all analog outputs to any mA value within the 0–22 mA range. Press [ENTER] to exit from this display.

```
A 0.28  μS/cm
A 25.00 °C
Diagnostics
Set Analog Outputs ▲
```

```
A 0.28  μS/cm
A 25.00 °C
Analog out1 = 04.0 mA
Analog out2 = 04.0 mA ▲
```

11.1.9 Read Analog Outputs

This menu shows the mA value of the analog Outputs. Press [ENTER] to exit from this display.

```
A 0.28  μS/cm
A 25.00 °C
Diagnostics
Read Analog Outputs ▲
```

```
A 0.28  μS/cm
A 25.00 °C
Analog out1 = 20.5 mA
Analog out2 = 20.5 mA ▲
```

11.2 Calibrate

(PATH: Menu/Service/Calibrate)

This menu has the options to calibrate the transmitter and the analog outputs and also allows the unlocking of calibration functionality.

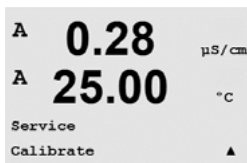

11.2.1 Calibrate Meter (only for channel A)

The M400 transmitter is factory calibrated within specifications. It is not normally necessary to perform meter re-calibration unless extreme conditions cause an out of spec operation shown by Calibration Verification. Periodic verification/re-calibration may also be necessary to meet Q.A. requirements. Meter calibration can be selected as Current (used for most dissolved oxyge, Voltage, Rg Diagnostic, Rr Diagnostic (used for pH), and Temperature (used for all measurements).

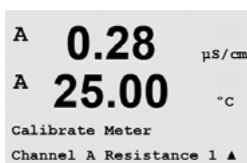

11.2.1.1 Temperature

Temperature is performed as a three point calibration. The table above shows the resistance values of these three points.

Navigate to the Calibrate Meter screen and choose Temperature calibration for Channel A.

Press [ENTER] to begin temperature calibration process

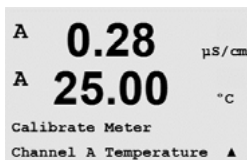

The first text line will ask for the Point 1 temperature resistance value (this will correspond to Temperature 1 value shown on the Calibration Module Accessory). The second text line will show the measured resistance value. When the value stabilizes, press [ENTER] to perform calibration.

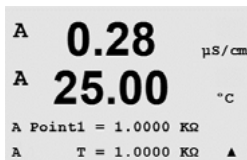

The transmitter screen will then prompt the user to enter the value for Point 2, and T2 will display the measured resistance value. When this value stabilizes, press [ENTER] to calibrate this range.

Repeat these steps for Point 3.

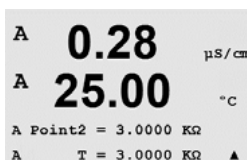

Press [ENTER] to bring up a confirmation screen. Select Yes to save the calibration values and the successful Calibration is confirmed on the display.

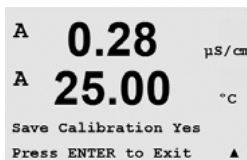

The transmitter will return to the Measurement mode in approximately 5 seconds.

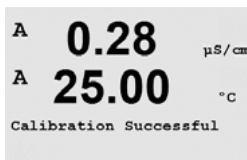

11.2.1.2 Current

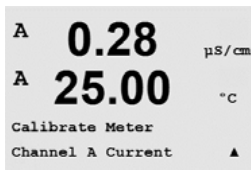

Current Calibration is performed as a two point calibration. Navigate to the Calibrate Meter screen and select Channel A.

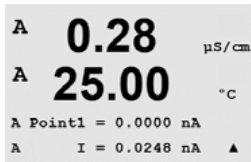

Enter the value for Point 1, in milliamps, of the current source connected to the input. The second display line will show the measured current. Press [ENTER] to begin the calibration process.

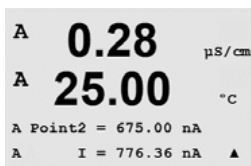

Enter the value for Point 2, in milliamps, of the current source connected to the input. The second display line shows the measured current.

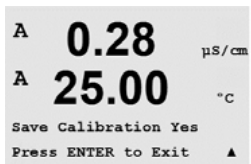

Pressing the [ENTER] key after entering Point 2 will bring up a confirmation screen. Select Yes to save the calibration values and the successful Calibration is confirmed on the display. The transmitter will return to the Measurement mode in approximately 5 seconds.

11.2.1.3 Voltage

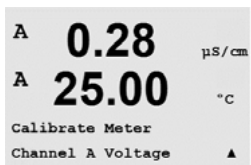

Voltage Calibration is performed as a two point calibration. Navigate to the Calibrate Meter screen and select Channel A and Voltage.

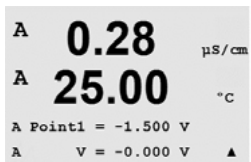

Enter the value for Point 1 in, volts, connected to the input. The second display line will show the measured voltage. Press [ENTER] to begin the calibration process.

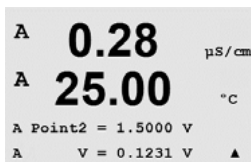

Enter the value for Point 2, in volts, of the source connected to the input. The second display line shows the measured voltage.

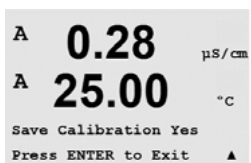

Pressing the [ENTER] key after entering Point 2 will bring up a confirmation screen. Select Yes to save the calibration values and the successful Calibration is confirmed on the display. The transmitter will return to the Measurement mode in approximately 5 seconds.

11.2.1.4 Rg Diagnostic

Rg Diagnostic is performed as a two point calibration. Navigate to the Calibrate Meter screen and select Channel A and Rg Diagnostic.

```
A 0.28  μS/cm
A 25.00 °C
Calibrate Meter
Channel A Rg Diagnostic▲
```

Enter the value for Point 1 of the calibration according to the resistor connected across the pH glass electrode measuring input. Press [ENTER] to begin the calibration process.

```
A 0.28  μS/cm
A 25.00 °C
A Point1 = 30.000 MΩ
A Rg = 572.83 Ω ▲
```

Enter the value for Point 2 of the calibration according to the resistor connected across the pH glass electrode measuring input.

```
A 0.28  μS/cm
A 25.00 °C
A Point2 = 500.00 MΩ
A Rg = 572.83 Ω ▲
```

Pressing the [ENTER] key after entering Point 2 will bring up a confirmation screen. Select Yes to save the calibration values and the successful Calibration is confirmed on the display. The transmitter will return to the Measurement mode in approximately 5 seconds.

```
A 0.28  μS/cm
A 25.00 °C
Save Calibration Yes
Press ENTER to Exit ▲
```

11.2.1.5 Rr Diagnostics

Rr Diagnostic is performed as a two point calibration. Navigate to the Calibrate Meter screen and select Channel A and Rr Diagnostic.

```
A 0.28  μS/cm
A 25.00 °C
Calibrate Meter
Channel A Rr Diagnostic▲
```

Enter the value for Point 1 of the calibration according to the resistor connected across the pH reference measuring input. Press [ENTER] to begin the calibration process.

```
A 0.28  μS/cm
A 25.00 °C
A Point1 = 30.000 KΩ
A Rr = 29.448 KΩ ▲
```

Enter the value for Point 2 of the calibration according to the resistor connected across the pH reference measuring input.

```
A 0.28  μS/cm
A 25.00 °C
A Point2 = 200.00 KΩ
A Rr = 29.446 KΩ ▲
```

Pressing the [ENTER] key after entering Point 2 will bring up a confirmation screen. Select Yes to save the calibration values and the successful Calibration is confirmed on the display. The transmitter will return to the Measurement mode in approximately 5 seconds.

```
A 0.28  μS/cm
A 25.00 °C
Save Calibration Yes
Press ENTER to Exit ▲
```

11.2.2 Calibrate Analog

Select the Analog Output you wish to calibrate. Each Analog output can be calibrated at 4 and 20 mA.

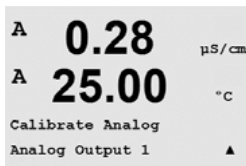

Connect an accurate milliamp meter to the Analog output terminals and then adjust the five digit number in the display until the milliamp meter reads 4.00 mA and repeat for 20.00 mA.



As the five digit number is increased the output current increases and as the number is decreased the output current decreases. Thus coarse changes in the output current can be made by changing the thousands or hundreds digits and fine changes can be made by changing the tens or ones digits.

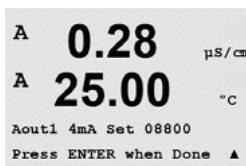

Pressing the [ENTER] key after entering both values will bring up a confirmation screen. Selecting No will discard the entered values, selecting Yes will make the entered values the current ones.

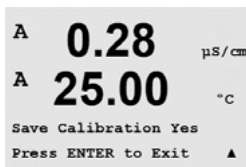

11.2.3 Calibrate Unlock

Select this Menu to configure the CAL Menu, see Section 7.

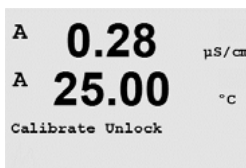

Selecting Yes means that Meter and Analog Output calibration Menus will be selectable under the CAL Menu. Selecting No means that only the Sensor calibration is available under the CAL Menu. Press [ENTER] after the selection to display a confirmation screen.

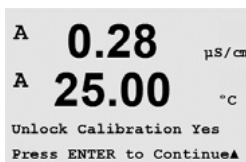

11.3 Tech Service

(PATH: Menu/Tech Service)



Note: This Menu is for Mettler Toledo Service personnel use only.

12 Info

(PATH: Info)

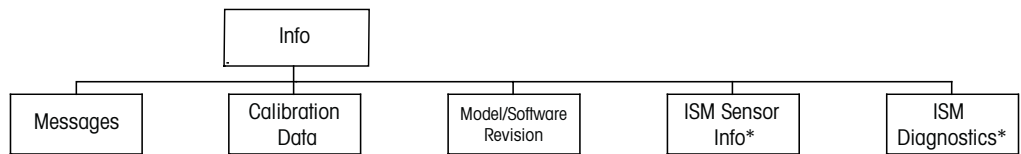

* Only available in combination with ISM sensors

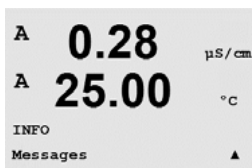

Pressing the ▼ key will display the Info Menu with the options Messages, Calibration Data and Model/Software Revision.

12.1 Messages

(PATH: Info/Messages)

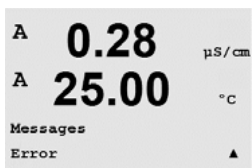

The most recent message is displayed. The up and down arrow keys allow scrolling through the last four messages that have occurred.



Clear Messages clears all the messages. Messages are added to the message list when the condition that generates the message first occurs. If all messages are cleared and a message condition still exists and started before the clear then it will not appear in the list. For this message to re-occur in the list the condition must go away and then reappear.

12.2 Calibration Data

(PATH: Info/Calibration Data)

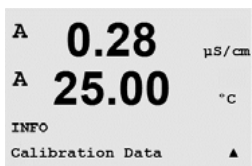

Selecting Calibration Data displays the calibration constants for each sensor.

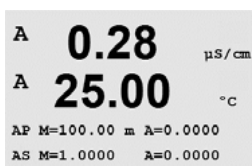

P = calibration constants for the primary measurement
 S = calibration constants for the secondary measurement

Press [ENTER] to exit from this display.

12.3 Model/Software Revision

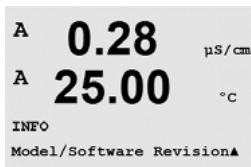

Selecting Model/Software Revision will display the model number, serial number and installed software revision.



The displayed information is important for any Service call. Press [ENTER] to return to the normal measurement mode.

12.4 ISM Sensor Info (available when ISM sensor connected)



After plugging in an ISM sensor, the following information about the sensor will be shown in this menu. Use up and down arrows to scroll in the menu.



Type: Type of sensor (e.g. InPro 3250)
 Cal Date: Date of the last adjustment
 Serial-No.: Serial number of the connected Sensor
 Part-No.: Part number of the connected Sensor

12.5 ISM Sensor Diagnostics (available when ISM sensor connected)

Cal History

The calibration history is stored with a time stamp in the ISM Sensor and is displayed on the transmitter. The Calibration history offers the following information:

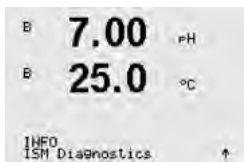

Fact (Factory calibration): This is the original dataset, determined in the factory. This dataset remains stored in the sensor for reference and cannot be overwritten.



Act (Actual adjustment): This is the actual calibration dataset which is used for the measurement. This dataset moves to Cal-2 position after the next adjustment.



1. Adj (First adjustment): This is the first adjustment after the factory calibration. This dataset remains stored in the sensor for reference and cannot be overwritten

Cal-1 (last calibration/adjustment): This is the last executed calibration/adjustment. This dataset moves to Cal-2 and then to Cal-3 when a new calibration/adjustment is performed. Afterwards, the dataset is not available anymore.

Cal-2 and Cal-3 acting in the same way as Cal-1.

Definition:

Adjustment: The calibration procedure is completed and the calibration values are taken over and used for the measurement (Act) and stated in Cal-1. The current values from Act will move to Cal-2.

Calibration: The calibration procedure is completed, but the calibration values will not be overtaken and the measurement continuous with the last valid adjustment dataset (Act). The dataset will be stored under Cal-1.

The calibration history is used for the estimation of the lifetime indicator for ISM sensors.

Sensor Monitoring

The sensor monitoring shows the different diagnostics functions available for each ISM sensor. The following information is available:



Lifetime indicator: Shows an estimation of the remaining lifetime to ensure a reliable measurement. The lifetime is indicated in days (d) and percentage (%). For a description of the Lifetime indicator, please see section 8.6 ISM Setup. For Oxygen sensors, the lifetime indicator is related to the inner-body of the sensor or the OptoCap for optical sensors. If you want to bring the bar indicator on the screen, see chapter 8.7.5 to activate ISM functions.



Adaptive Cal Timer: This timer shows a Adaptive Cal Timer, when the next calibration should be performed to keep the best possible measurement performance. The Adaptive Cal Timer is indicated in days (d) and percentage (%). For a description of the Adaptive Cal Timer, please see section 8.6 ISM Setup.



Time to Maintenance: This timer shows a Time to Maintenance, when the next cleaning cycle should be performed to keep the best possible measurement performance. The Time to Maintenance is indicated in days (d) and percentage (%). For a description of the Time to Maintenance, please see section 8.6 ISM Setup. For oxygen sensors, the Time to Maintenance indicates a maintenance cycle for the membrane and electrolyte.

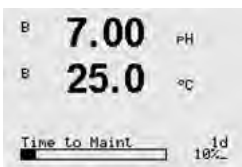

Max. Temperature

The maximum temperature shows the maximum temperature that this sensor has ever seen, together with a time stamp of this maximum. This value is stored on the sensor and cannot be changed. During autoclaving the Max temperature is not recorded.

Max. Temperature
Tmax XXX°C YY/MM/DD



CIP Cycles

Shows the amount of CIP cycles that the sensor has been exposed to. For a description of the CIP Cycle indicator, please see section 8.6 ISM Setup

CIP Cycles xxx of xxx

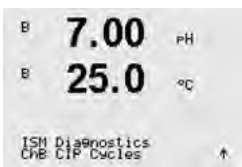

SIP Cycles

Shows the amount of SIP cycles that the sensor has been exposed to. For a description of the SIP Cycle indicator, please see section 8.6 ISM Setup

SIP Cycles xxx of xxx

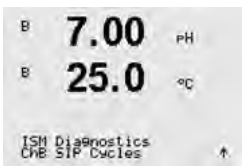

Autoclaving Cycles

Shows the amount of Autoclaving cycles that the sensor has been exposed to. For a description of the AutoClave Cycle indicator, please see section 8.6 ISM Setup

Autoclaving Cycles xxx of xxx

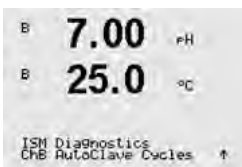

13 Maintenance

13.1 Front Panel Cleaning

Clean the front panel with a damp soft cloth (water only, no solvents). Gently wipe the surface and dry with a soft cloth.

14 Troubleshooting

If the equipment is used in a manner not specified by Mettler-Toledo Thornton, Inc., the protection provided by the equipment may be impaired.

Review the table below for possible causes of common problems:

Problem	Possible Cause
Display is blank.	<ul style="list-style-type: none"> – No power to M400. – Blown fuse. – LCD display contrast set incorrectly. – Hardware failure.
Incorrect measurement readings.	<ul style="list-style-type: none"> – Sensor improperly installed. – Incorrect units multiplier entered. – Temperature compensation incorrectly set or disabled. – Sensor or transmitter needs calibration. – Sensor or patch cord defective or exceeds recommended maximum length. – Hardware failure.
Measurement readings not stable.	<ul style="list-style-type: none"> – Sensors or cables installed too close to equipment that generates high level of electrical noise. – Recommended cable length exceeded. – Averaging set too low. – Sensor or patch cord defective.
Displayed  is flashing.	<ul style="list-style-type: none"> – Setpoint is in alarm condition (setpoint exceeded).
Cannot change menu settings.	<ul style="list-style-type: none"> – User locked out for security reasons.



14.1 Changing the Fuse

Make sure that the mains cable is unplugged before changing the fuse. This operation should only be carried out by personnel familiar with the transmitter and who are qualified for such work.

If the power consumption of the M400 transmitter is too high or a manipulation leads to a short circuit the fuse will blow. In this case remove the fuse and replace it with one specified in Section [15](#).

14.2 Warning- and Alarm list pH

Warnings	Description
Warning pH slope > 101%	Slope too big
Warning pH Slope < 95%	Slope too small
Warning pH Zero > 7.5 pH	Zero offset too big
Warning pH Zero < 6.5 pH	Zero offset too small
Warning pHGs change < 0.3	Glass electrode resistance changed by more than factor 0.3
Warning pHGs change > 3	Glass electrode resistance changed by more than factor 3
Warning pHRef change < 0.3	Reference electrode resistance changed by more than factor 0.3
Warning pHRef change > 3	Reference electrode resistance changed by more than factor 3

Alarms	Description
Watchdog time-out	SW/System fault
Error pH Slope > 102%	Slope too big
Error pH Slope < 90%	Slope too small
Error pH Zero > 8.0 pH	Zero offset too big
Error pH Zero < 6.0 pH	Zero offset too small
Error pH Ref Res > 150 KΩ	Reference electrode resistance too big (break)
Error pH Ref Res < 2000 Ω	Reference electrode resistance too small (short)
Error pH Gls Res > 2000 MΩ	Glass electrode resistance too big (break)
Error pH Gls Res < 5 MΩ	Glass electrode resistance too small (short)

14.3 Warning- and Alarm list O₂

Warnings	Description
Warning O ₂ Slope < -90nA	Slope too big
Warning O ₂ Slope > -35nA	Slope too small
Warning O ₂ ZeroPt > 0.3nA	Zero offset too big
Warning O ₂ ZeroPt < -0.3nA	Zero offset too small

Alarms	Description
Watchdog time-out	SW/System fault
Error O ₂ Slope < -110 nA	Slope too big
Error O ₂ Slope > -30 nA	Slope too small
Error O ₂ ZeroPt > 0.6 nA	Zero offset too big
Error O ₂ ZeroPt < -0.6 nA	Zero offset too small

14.4 Warning- and Alarm list Optical O₂

Warnings	Description
Chx Cal Required	ATC = 0
Chx CIP Counter Expired	Limit of CIP cycles reached
Chx SIP Counter Expired	Limit of SIP cycles reached
Chx Autocl. Count. Exp.	Limit of autoclaving cycles reached

Alarms	Description
Chx Change Spot	Replace OptoCap
Chx Signal error	Signal or Temperature out of spec
Chx Shaft error	Temperature bad, stray light too high (Glass fiber broken), shaft removed
Chx Hardware error	Electronical components fail

15 Accessories and Spare Parts

Please contact your local Mettler-Toledo Sales office or representative for details for additional accessories and spare parts.

Description	Order no.
Pipe Mount Kit for ½ DIN models	52 500 212
Panel Mount Kit for ½ DIN models	52 500 213
Protective Hood for ½ DIN models	52 500 214

16 Specifications

16.1 General specifications

Conductivity/resistivity Specifications	
0.01 cm ⁻¹ constant sensor	0.002 to 200 µS/cm
0.1 cm ⁻¹ constant sensor	0.02 to 2000 µS/cm
10 cm ⁻¹ constant sensor	10 to 40,000 µS/cm
4-electrode sensor	0.01 to 650 mS/cm
Chemical concentration curves	HCl (0.01–15%), H ₂ SO ₄ (0–25%), NaOH (0.01–13%), H ₃ PO ₄ (0–35%)
Temperature input	PT1000/PT100
Temperature measuring range	– 40 to + 200.0 °C (–40 to 392 °F)
Sensor maximum distance	61 m (200 ft); 15 m (50 ft with 4-E sensors)
Cond/Res accuracy	± 0.5% of reading or 0.25Ω, whichever is greater, Up to 10 MΩ-cm
Repeatability	+/- 0.25% of reading or 0.25 ohm, whichever is greater
Resolution	auto/0.001/0.01/0.1/1 (can be selected)
Temperature resolution	0.1 °C (0.1 °F), (can be selected)
Temperature relative accuracy	± 0.25 °C (± 0.45 °F)
Temperature repeatability	± 0.13 °C (± 0.23 °F)
Ratings/Approvals	UL Listed, CE Compliant
pH Specifications	
pH range	–1.00 to 15.00 pH
pH Resolution	auto/0.01/0.1/1 (can be selected)
pH Relative accuracy	± 0.03 pH
mV range	–1500 to 1500 mV
mV Resolution	1 mv
mV Relative accuracy	± 2 mV
Temperature input	Pt1000/Pt100/NTC22K
Temperature measuring range	–30 to 130 °C (22 to 266 °F)
Available Buffer Sets:	
MT-9 buffers, MT-10 buffers, NIST Technical Buffers, NIST Standard Buffers (DIN 19266:2000–01), JIS Standard, Hach buffers, CIBA (94) buffers, Merck Titrisols-Reidel Fixanals, WTW buffers	
Dissolved Oxygen Specifications	
Measuring current (Air) at 25 °C (77 °F), 1 bar (14.5 psi)	ppm: 25 nA to 130 nA/ppb: 200 nA to 550 nA traces: 1500 nA to 6500 nA
Concentration range	0.1 ppb (µg/L) to 20.00ppm (mg/L)
Relative Accuracy	± 0.5% of full scale reading
Resolution	30 pA
Temperature input	NTC 22 kΩ/Pt1000
Temperature measuring range	–10 to 80 °C (14 to 176 °F)

16.2 Electrical specifications

Power requirements	100 to 240 V AC or 20 to 30 V DC, 10 VA, AWG 14 <2.5 mm ²
Frequency	50 to 60 Hz
Analog output signals	Four 0/4 to 20 mA outputs, galvanically isolated from input and from earth/ground
Measurement Error through analog outputs	< +/- 0.05 mA over 1 to 20 mA range, < +/- 0.1 mA over 0 to 1 mA range
Analog output configuration	Linear, Bi-Linear, Logarithmic, Autoranging
Load	max. 500 Ω
Connection terminals	Detachable screw terminals
Digital communication	USB port, Type B connector
PID process controller	Pulse length, pulse frequency or analog control
Connection terminals	Detachable screw terminals
Digital Input	2
Mains power fuse	1.0 A slow blow type FC
Relays	2-SPDT mechanical 250VAC, 30 VDC, 3 Amps 2-SPST mechanical rated at 250VAC, 3 Amps 2-Reed 250VAC or DC, 0.5 A
Alarm Relay delay	0–999 s
Keypad	5 tactile feedback keys
Display	four-line
Max. cable length ISM	80 m



NOTE: This is a 4-wire-product with an active 4–20 mA analog output.
Please do not supply to Pin1–Pin6 of TB2.

16.3 Mechanical specifications

Dimensions (housing – H x W x D)*	144 x 144 x 116 mm
Front bezel – H x W	150 x 150 mm
Max. D – panel mounted	87 mm (excludes plug-in connectors)
Weight	0.95 kg (2 lb)
Material	ABS/polycarbonate
Ingress rating	IP 65 only when back cover is attached

* H=Height, W=Width, D=Depth

16.4 Environmental specifications

Storage temperature	–40 to 70 °C (–40 to 158 °F)
Ambient temperature operating range	–10 to 50 °C (14 to 122 °F)
Relative humidity	0 to 95% non-condensing
Emissions	According to EN55011 Class A
Hazardous areas	FM: cFMus Class I Division 2 (pending) / Atex: ATEX Zone 2 (pending)

17 Default tables

17.1 General

Alarm	Relay	2	
	Diagnostics	off	
	Power Failure	off	
	Software Failure	off	
	Delay	1	sec
	Hysteresis	0	
	State	inverted	
Clean	Relay	1	
	Interval	0	Hrs
	Clean Time	0	Sec
	State	normal	
	Delay	0	
	Hysteresis	0	
Language		English	
Passwords	Administrator	00000	
	Operator	00000	
All Relays (unless otherwise specified)	Delay	10	Sec
	Hysteresis	5	%
	State	normal	
	Hold mode	Last	
Lockout	(on/off)	no = off	
Channel A	Measurement a	Resistivity pH	Ω -cm
	Measurement b	temperature	$^{\circ}$ C
Channel B	Measurement c	Resistivity pH	Ω -cm
	Measurement d	Temperature	$^{\circ}$ C
Cal constants	Cond/Res	M=0.1, A=0.0	
	Dissolved Oxygen	M=1.0, A=0.0	
	pH	M=1.0, A=0.0	
	Temperature	M=1.0, A=0.0	
Analog Out	1	a – Cond/Resistivity	M Ω -cm
	2	b – temperature	$^{\circ}$ C
	3	c – Cond/Resistivity	M Ω -cm
	4	d – Temperature	$^{\circ}$ C
All analog out	Mode	4 – 20 mA	
	Type	normal	
	Alarm	off	
	Hold mode	last value	
Conductivity/Resistivity	Value 4 mA	10	M Ω -cm
	Value 20 mA	20	M Ω -cm
Dissolved Oxygen	Value 4 mA	0.000	ppb
	Value 20 mA	100.0	ppb
pH	Value 4 mA	2.000	pH
	Value 20 mA	12.00	pH
Temperature	Value 4 mA	0	$^{\circ}$ C
	Value 20 mA	100	$^{\circ}$ C
Set point 1	Measurement	a	
	Type	Off	
	Value	0	
Relay 3	Set Point	1	
Set point 2	Measurement	c	
	Type	Off	
	Value	0	
Relay 4	Set Point	2	
Resolution	Temperature	0.1	$^{\circ}$ C
	Cond/Res	0.01	Ω -cm

17.2 M400

Parameter	Sub parameter	Value	Unit
Alarm	relay	2	
	diagnostics	No	
	Cond cell	No	
	power failure	No	
	software failure	No	
	Disconnect ChB	No	
	DLI monitor	No	
	CIP cycle counter	No	
	SIP cycle counter	No	
	Autoclave cycle c. cycle counter	No	
	delay	1	sec
	hysteresis	0	
	state	inverted	
Clean	relay	1	
	hold mode	Hold	
	Interval	0	Hrs
	clean time	0	Sec
	state	normal	
	delay	0	
	hysteresis	0	
Language		English	
Passwords	administrator	00000	
	operator	00000	
Analog Out	1	a –	
	2	b	
	3		
	4		
All Relays(Unless Otherwise Specified)	delay	10	sec
	hysteresis	5	%
	state	normal	
	hold mode	Last	
Lockout	Yes/No	No	
Cal constants (Analog sensor)	Cond/Res	M=0.1, A=0.0	
	O ₂	S= -70.00 nA, Z= 0.00 nA (O ₂ high) S= -350.00 nA, Z= 0.00 nA (O ₂ low)	
	pH	S= 100.0%, Z= 7.000 pH	
	temperature	M= 1.0, A= 0.0	

Parameter	Sub parameter	Value	Unit
Analog Out	1	a	
	2	b	
All analog out	mode	4–20 mA	
	type	normal	
	alarm	off	
	hold mode	last value	
Conductivity/ Resistivity	value 4 mA	10	MΩ-cm
	Value 20 mA	20	MΩ-cm
O ₂	value 4 mA	0	%sat
	Value 20 mA	100	%sat
pH	value 4 mA	2	pH
	Value 20 mA	12	pH
Temperature	value 4 mA	0	°C
	Value 20 mA	100	°C
Set point 1	measurement	a	
	type	off	
	value	0	
Relay 3	set point	1	
Set point 2	measurement	b	
	type	off	
	value	0	
Relay 4	set point	2	

17.3 Error messages

ISM
ChX Disconnected
Chx Change Sensor
Chx Maint Required
Chx Cal Required
Chx CIP Counter Expired
Chx SIP Counter Expired
Chx AutCI Count Expired
pH – Warnings
Warning pH slope > 102%
Warning pH Slope < 90%
Warning pH Zero >7.5 pH
Warning pH Zero < 6.5 pH
Warning pHGs change < 0.3
Warning pHGs change > 3
Warning pHRef change < 0.3
Warning pHRef change > 3
pH – Alarms
Watchdog time-out
Error pH Slope > 103%
Error pH Slope < 80%
Error pH Zero > 8.0 pH
Error pH Zero < 6.0 pH
Error pH Ref Res >150 K Ω
Error pH Ref Res < 2000 Ω
Error pH GIs Res > 2000 M Ω
Error pH GIs Res < 5 M Ω
O₂ high – Warnings
Warning DO Slope < -90 nA
Warning DO Slope > -35 nA
Warning DO ZeroPt > 0.3 nA
Warning DO ZeroPt < -0.3 nA
O₂ high – Alarms
Watchdog time-out
Error DO Slope < -110 nA
Error DO Slope > -30 nA
Error DO ZeroPt > 0.6 nA
Error DO ZeroPt < -0.6 nA

O₂ low – Warnings
Warnings
Warning DO Slope < -460 nA
Warning DO Slope > -250 nA
Warning DO ZeroPt > 0.5 nA
Warning DO ZeroPt < -0.5 nA
O₂ low – Alarms
Watchdog time-out
Error Install O2 Jumper
Error DO Slope < -525 nA
Error DO Slope > -220 nA
Error DO ZeroPt > 1.0 nA
Error DO ZeroPt < -1.0 nA
Conductivity – Alarms
Alarms
Watchdog time-out
Cond Cell open
Cond Cell shorted

18 Warranty

METTLER TOLEDO warrants this product to be free from significant deviations in material and workmanship for a period of one year from the date of purchase. If repair is necessary and not the result of abuse or misuse within the warranty period, please return by freight pre-paid and amendment will be made without any charge. METTLER TOLEDO's Customer Service Dept. will determine if the product problem is due to deviations or customer abuse. Out-of-warranty products will be repaired on an exchange basis at cost.

The above warranty is the only warranty made by METTLER TOLEDO and is lieu of all other warranties, expressed or implied, including, without limitation, implied warranties of merchantability and fitness for a particular purpose. METTLER TOLEDO shall not be liable for any loss, claim, expense or damage caused by, contributed to or arising out of the acts or omissions of the Buyer or Third Parties, whether negligent or otherwise. In no event shall METTLER TOLEDO's liability for any cause of action whatsoever exceed the cost of the item giving rise to the claim, whether based in contract, warranty, indemnity, or tort (including negligence).

19 Buffer tables

M400 transmitters have the ability to do automatic pH buffer recognition. The following tables show different standard buffers that are automatically recognized.

19.1 Mettler-9

Temp (°C)	pH of buffer solutions			
0	2.03	4.01	7.12	9.52
5	2.02	4.01	7.09	9.45
10	2.01	4.00	7.06	9.38
15	2.00	4.00	7.04	9.32
20	2.00	4.00	7.02	9.26
25	2.00	4.01	7.00	9.21
30	1.99	4.01	6.99	9.16
35	1.99	4.02	6.98	9.11
40	1.98	4.03	6.97	9.06
45	1.98	4.04	6.97	9.03
50	1.98	4.06	6.97	8.99
55	1.98	4.08	6.98	8.96
60	1.98	4.10	6.98	8.93
65	1.99	4.13	6.99	8.90
70	1.99	4.16	7.00	8.88
75	2.00	4.19	7.02	8.85
80	2.00	4.22	7.04	8.83
85	2.00	4.26	7.06	8.81
90	2.00	4.30	7.09	8.79
95	2.00	4.35	7.12	8.77

19.2 Mettler-10

Temp (°C)	pH of buffer solutions			
0	2.03	4.01	7.12	10.32
5	2.02	4.01	7.09	10.25
10	2.01	4.00	7.06	10.18
15	2.00	4.00	7.04	10.12
20	2.00	4.00	7.02	10.06
25	2.00	4.01	7.00	10.01
30	1.99	4.01	6.99	9.97
35	1.99	4.02	6.98	9.93
40	1.98	4.03	6.97	9.89
45	1.98	4.04	6.97	9.86
50	1.98	4.06	6.97	9.83
55	1.98	4.08	6.98	9.83
60	1.98	4.10	6.98	9.83
65	1.99	4.13	6.99	9.83
70	1.99	4.16	7.00	9.83
75	2.00	4.19	7.02	9.83
80	2.00	4.22	7.04	9.83
85	2.00	4.26	7.06	9.83
90	2.00	4.30	7.09	9.83
95	2.00	4.35	7.12	9.83

19.3 NIST Technical Buffers

Temp (°C)	pH of buffer solutions				
0	1.67	4.00	7.115	10.32	13.42
5	1.67	4.00	7.085	10.25	13.21
10	1.67	4.00	7.06	10.18	13.01
15	1.67	4.00	7.04	10.12	12.80
20	1.675	4.00	7.015	10.06	12.64
25	1.68	4.005	7.00	10.01	12.46
30	1.68	4.015	6.985	9.97	12.30
35	1.69	4.025	6.98	9.93	12.13
40	1.69	4.03	6.975	9.89	11.99
45	1.70	4.045	6.975	9.86	11.84
50	1.705	4.06	6.97	9.83	11.71
55	1.715	4.075	6.97	9.83*	11.57
60	1.72	4.085	6.97	9.83*	11.45
65	1.73	4.10	6.98	9.83*	11.45*
70	1.74	4.13	6.99	9.83*	11.45*
75	1.75	4.14	7.01	9.83*	11.45*
80	1.765	4.16	7.03	9.83*	11.45*
85	1.78	4.18	7.05	9.83*	11.45*
90	1.79	4.21	7.08	9.83*	11.45*
95	1.805	4.23	7.11	9.83*	11.45*

*Extrapolated

19.4 NIST standard buffers (DIN and JIS 19266: 2000–01)

Temp (°C)	pH of buffer solutions			
0				
5	1.668	4.004	6.950	9.392
10	1.670	4.001	6.922	9.331
15	1.672	4.001	6.900	9.277
20	1.676	4.003	6.880	9.228
25	1.680	4.008	6.865	9.184
30	1.685	4.015	6.853	9.144
35	1.694	4.028	6.841	9.095
40	1.697	4.036	6.837	9.076
45	1.704	4.049	6.834	9.046
50	1.712	4.064	6.833	9.018
55	1.715	4.075	6.834	8.985
60	1.723	4.091	6.836	8.962
70	1.743	4.126	6.845	8.921
80	1.766	4.164	6.859	8.885
90	1.792	4.205	6.877	8.850
95	1.806	4.227	6.886	8.833



NOTE: The pH(S) values of the individual charges of the secondary reference materials are documented in a certificate of an accredited laboratory. This certificate is supplied with the respective buffer materials. Only these pH(S) values shall be used as standard values for the secondary reference buffer materials. Correspondingly, this standard does not include a table with standard pH values for practical use. The table above only provides examples of pH(PS) values for orientation.

19.5 Hach buffers

Buffer values up to 60 °C as specified by Bergmann & Beving Process AB.

Temp (°C)	pH of buffer solutions		
0	4.00	7.14	10.30
5	4.00	7.10	10.23
10	4.00	7.04	10.11
15	4.00	7.04	10.11
20	4.00	7.02	10.05
25	4.01	7.00	10.00
30	4.01	6.99	9.96
35	4.02	6.98	9.92
40	4.03	6.98	9.88
45	4.05	6.98	9.85
50	4.06	6.98	9.82
55	4.07	6.98	9.79
60	4.09	6.99	9.76
65	4.09*	6.99*	9.76*
70	4.09*	6.99*	9.76*
75	4.09*	6.99*	9.76*
80	4.09*	6.99*	9.76*
85	4.09*	6.99*	9.76*
90	4.09*	6.99*	9.76*
95	4.09*	6.99*	9.76*

*Values complemented

19.6 Ciba (94) buffers

Temp (°C)	pH of buffer solutions			
0	2.04	4.00	7.10	10.30
5	2.09	4.02	7.08	10.21
10	2.07	4.00	7.05	10.14
15	2.08	4.00	7.02	10.06
20	2.09	4.01	6.98	9.99
25	2.08	4.02	6.98	9.95
30	2.06	4.00	6.96	9.89
35	2.06	4.01	6.95	9.85
40	2.07	4.02	6.94	9.81
45	2.06	4.03	6.93	9.77
50	2.06	4.04	6.93	9.73
55	2.05	4.05	6.91	9.68
60	2.08	4.10	6.93	9.66
65	2.07*	4.10*	6.92*	9.61*
70	2.07	4.11	6.92	9.57
75	2.04*	4.13*	6.92*	9.54*
80	2.02	4.15	6.93	9.52
85	2.03*	4.17*	6.95*	9.47*
90	2.04	4.20	6.97	9.43
95	2.05*	4.22*	6.99*	9.38*

*Extrapolated

19.7 Merck Titrisole, Riedel-de-Haën Fixanale

Temp (°C)	pH of buffer solutions				
0	2.01	4.05	7.13	9.24	12.58
5	2.01	4.05	7.07	9.16	12.41
10	2.01	4.02	7.05	9.11	12.26
15	2.00	4.01	7.02	9.05	12.10
20	2.00	4.00	7.00	9.00	12.00
25	2.00	4.01	6.98	8.95	11.88
30	2.00	4.01	6.98	8.91	11.72
35	2.00	4.01	6.96	8.88	11.67
40	2.00	4.01	6.95	8.85	11.54
45	2.00	4.01	6.95	8.82	11.44
50	2.00	4.00	6.95	8.79	11.33
55	2.00	4.00	6.95	8.76	11.19
60	2.00	4.00	6.96	8.73	11.04
65	2.00	4.00	6.96	8.72	10.97
70	2.01	4.00	6.96	8.70	10.90
75	2.01	4.00	6.96	8.68	10.80
80	2.01	4.00	6.97	8.66	10.70
85	2.01	4.00	6.98	8.65	10.59
90	2.01	4.00	7.00	8.64	10.48
95	2.01	4.00	7.02	8.64	10.37

19.8 WTW buffers

Temp (°C)	pH of buffer solutions			
0	2.03	4.01	7.12	10.65
5	2.02	4.01	7.09	10.52
10	2.01	4.00	7.06	10.39
15	2.00	4.00	7.04	10.26
20	2.00	4.00	7.02	10.13
25	2.00	4.01	7.00	10.00
30	1.99	4.01	6.99	9.87
35	1.99	4.02	6.98	9.74
40	1.98	4.03	6.97	9.61
45	1.98	4.04	6.97	9.48
50	1.98	4.06	6.97	9.35
55	1.98	4.08	6.98	
60	1.98	4.10	6.98	
65	1.99	4.13	6.99	
70	2.00	4.16	7.00	
75	2.00	4.19	7.02	
80	2.00	4.22	7.04	
85	2.00	4.26	7.06	
90	2.00	4.30	7.09	
95	2.00	4.35	7.12	

Sales and Service:

Australia

Mettler-Toledo Ltd.
220 Turner Street
Port Melbourne
AUS - 3207 Melbourne/VIC
Phone +61 1300 659 761
Fax +61 3 9645 3935
e-mail info.mtaus@mt.com

Austria

Mettler-Toledo Ges.m.b.H.
Südrandstraße 17
A-1230 Wien
Phone +43 1 607 43 56
Fax +43 1 604 28 80
e-mail infoprocess.mtat@mt.com

Brazil

Mettler-Toledo Ind. e Com. Ltda.
Alameda Araguaia, 451
Alphaville
BR-06455-000 Barueri/SP
Phone +55 11 4166 7444
Fax +55 11 4166 7401
e-mail mettler@mettler.com.br
service@mettler.com.br

China

Mettler-Toledo Instruments
(Shanghai) Co. Ltd.
589 Gui Ping Road
Cao He Jing
CN-200233 Shanghai
Phone +86 21 64 85 04 35
Fax +86 21 64 85 33 51
e-mail mtcs@public.sta.net.cn

Croatia

Mettler-Toledo d.o.o.
Mandlova 3
HR-10000 Zagreb
Phone +385 1 292 06 33
Fax +385 1 295 81 40
e-mail mt.zagreb@mt.com

Czech Republic

Mettler-Toledo s.r.o.
Trebhostická 2283/2
CZ-100 00 Praha 10
Phone +420 2 72 123 150
Fax +420 2 72 123 170
e-mail sales.mtcz@mt.com

Denmark

Mettler-Toledo A/S
Naverland 8
DK-2600 Glostrup
Phone +45 43 27 08 00
Fax +45 43 27 08 28
e-mail info.mtdk@mt.com

France

Mettler-Toledo
Analyse Industrielle S.A.S.
30, Boulevard de Douaumont
BP 949
F-75829 Paris Cedex 17
Phone +33 1 47 37 06 00
Fax +33 1 47 37 46 26
e-mail mtpro-f@mt.com

Germany

Mettler-Toledo GmbH
Prozeßanalytik
Ockerweg 3
D-35396 Gießen
Phone +49 641 507 333
Fax +49 641 507 397
e-mail prozess@mt.com

Great Britain

Mettler-Toledo LTD
64 Boston Road, Beaumont Leys
GB-Leicester LE4 1AW
Phone +44 116 235 7070
Fax +44 116 236 5500
e-mail enquire.mtuk@mt.com

Hungary

Mettler-Toledo Kereskedelmi KFT
Teve u. 41
HU-1139 Budapest
Phone +36 1 288 40 40
Fax +36 1 288 40 50
e-mail mthu@t-online.hu

India

Mettler-Toledo India Private Limited
Amar Hill, Saki Vihar Road
Powai
IN-400 072 Mumbai
Phone +91 22 2803 1111
Fax +91 22 2857 5071
e-mail sales.mtin@mt.com

Italy

Mettler-Toledo S.p.A.
Via Vialba 42
I-20026 Novate Milanese
Phone +39 02 333 321
Fax +39 02 356 2973
e-mail
customercare.italia@mt.com

Japan

Mettler-Toledo K.K.
Process Division
4F Izumikan Sanbancho Bldg.
3-8 Sanbancho
Chiyoda-ku
JP-102-0075 Tokyo
Tel. +81 3 3222 7103
Fax +81 3 3222 7118
e-mail helpdesk.ing.jp@mt.com

Malaysia

Mettler-Toledo (M) Sdn Bhd
Bangunan Electrocon Holding, U 1-01
Lot 8 Jalan Astaka U8/84
Seksyen U8, Bukit Jelutong
MY-40150 Shah Alam Selangor
Phone +60 3 78 44 58 88
Fax +60 3 78 45 87 73
e-mail
MT-MY.CustomerSupport@mt.com

Mexico

Mettler-Toledo S.A. de C.V.
Pino No. 350, Col. Sta.
MA. Insurgentes, Col Atlampa
MX-06430 México D.F.
Phone +52 55 55 47 57 00
Fax +52 55 55 41 22 28
e-mail mt.mexico@mt.com

Poland

Mettler-Toledo (Poland) Sp.z.o.o.
ul. Poleczki 21
PL-02-822 Warszawa
Phone +48 22 545 06 80
Fax +48 22 545 06 88
e-mail polska@mt.com

Russia

Mettler-Toledo Vostok ZAO
Sretenskij Bulvar 6/1
Office 6
RU-101000 Moscow
Phone +7 495 651 98 86
Fax +7 495 621 63 53
+7 495 621 78 68
e-mail inforus@mt.com

Singapore

Mettler-Toledo (S) Pte. Ltd.
Block 28
Ayer Rajah Crescent #05-01
SG-139959 Singapore
Phone +65 6890 00 11
Fax +65 6890 00 12
+65 6890 00 13
e-mail precision@mt.com

Slovakia

Mettler-Toledo s.r.o.
Hattalova 12/A
SK-831 03 Bratislava
Phone +421 2 4444 12 20-2
Fax +421 2 4444 12 23
e-mail predaj@mt.com

Slovenia

Mettler-Toledo d.o.o.
Peske 12
SI-1236 Trzin
Phone +386 1 530 80 50
Fax +386 1 562 17 89
e-mail keith.racman@mt.com

South Korea

Mettler-Toledo (Korea) Ltd.
Yeil Building 1 & 2 F
124-5, YangJe-Dong
SeCho-Ku
KR-137-130 Seoul
Phone +82 2 3498 3500
Fax +82 2 3498 3555
e-mail Sales_MTKR@mt.com

Spain

Mettler-Toledo S.A.E.
C/Miguel Hernández, 69-71
ES-08908 L'Hospitalet de Llobregat
(Barcelona)
Phone +34 93 223 76 00
Fax +34 93 223 76 01
e-mail bcn.centralita@mt.com

Sweden

Mettler-Toledo AB
Virkesvägen 10
Box 92161
SE-12008 Stockholm
Phone +46 8 702 50 00
Fax +46 8 642 45 62
e-mail info.se@mt.com

Switzerland

Mettler-Toledo (Schweiz) GmbH
Im Langacher
Postfach
CH-8606 Greifensee
Phone +41 44 944 45 45
Fax +41 44 944 45 10
e-mail salesola.ch@mt.com

Thailand

Mettler-Toledo (Thailand) Ltd.
272 Soi Soonvijai 4
Rama 9 Rd., Bangkok
Huay Kwang
TH-10320 Bangkok
Phone +66 2 723 03 00
Fax +66 2 719 64 79
e-mail
MT-TH.CustomerSupport@mt.com

USA/Canada

Mettler-Toledo Ingold, Inc.
36 Middlesex Turnpike
Bedford, MA 01730, USA
Phone +1 781 301 8800
Toll free +1 800 352 8763
Fax +1 781 271 0681
e-mail mtprous@mt.com
ingold@mt.com



Management System
certified according to
ISO 9001 / ISO 14001

Subject to technical changes.
© Mettler-Toledo AG, Process Analytics
11/08 Printed in Switzerland. 52 121 378

Mettler-Toledo AG, Process Analytics
Im Hackacker 15, CH-8902 Urdorf, Switzerland
Tel. +41 44 729 62 11, Fax +41 44 729 66 36

www.mt.com/pro