

Capacity	Location and dimensions (mm [inch])					
	L1	L2	L3	L4	L6	D1
1T / 3T	140 [5.51]	110 [4.33]	12 [0.47]	27 [1.06]	83 [3.26]	11.2 [0.44]
10T / 30T	210 [8.26]	160 [6.29]	19 [0.74]	34 [1.33]	102.6 [4.03]	22 [0.86]

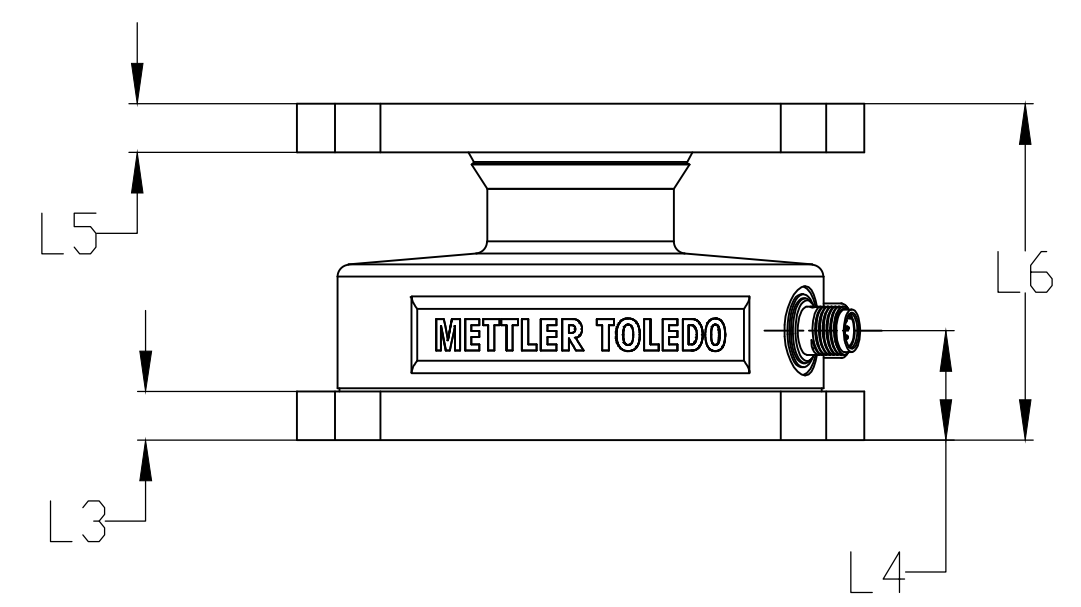
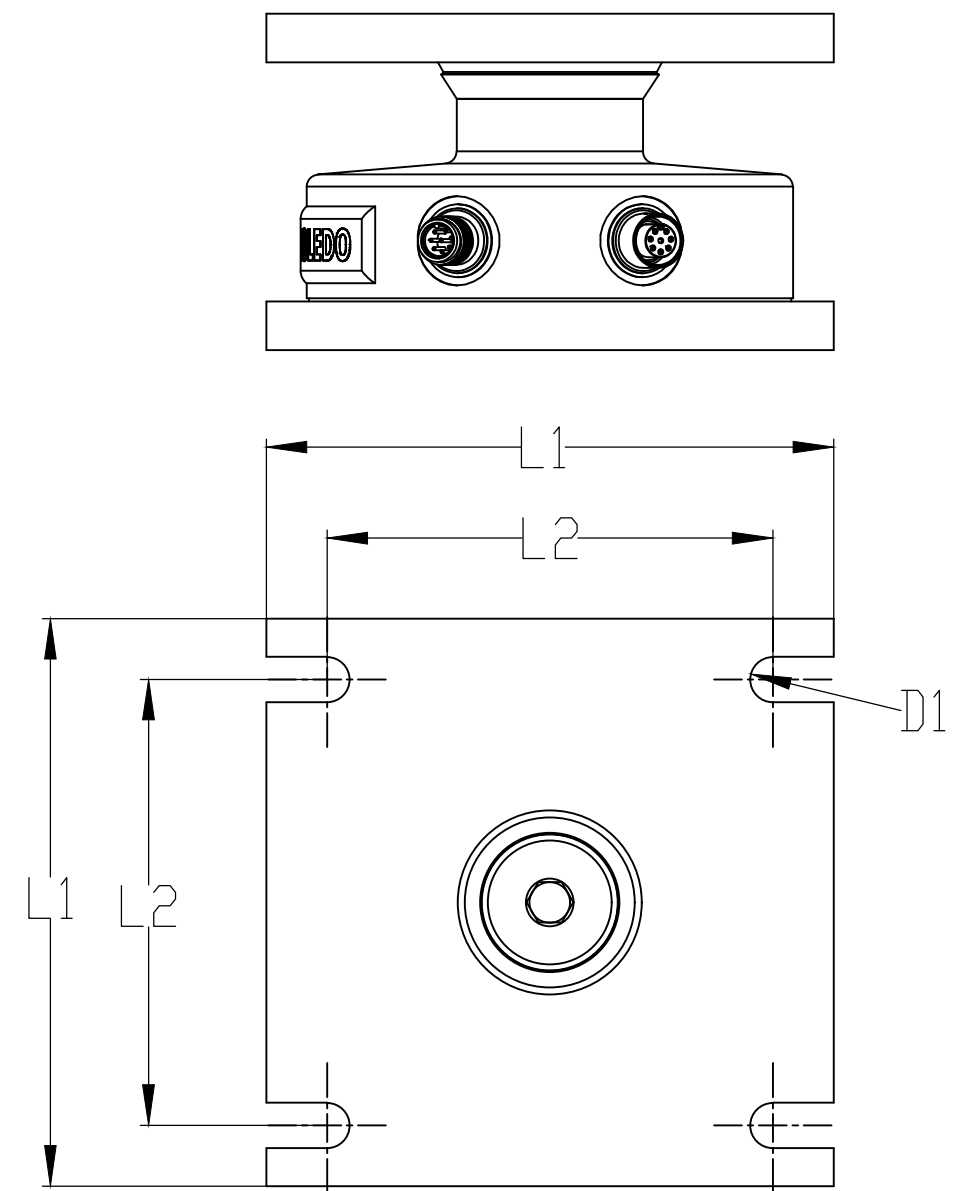

RoHS/REACH conform

Length	0.5...3	>3...6	>6...30	>30...120	>120...400	>400	Angle	>0...10	>10...50	>50...120	>120...400	R+Chamfer	0.5...3	>3...6	>6
medium	±0.1	±0.1	±0.2	±0.3	±0.5	±0.8	medium	±1°	±0°30'	±0°20'	±0°10'	medium	±0.2	±0.5	±1

Material: - Standard threads: ISO: 6H / 6g ANSI: class 2
Material2: - Size ISO 14405

Finish: - General geometrical tolerances ISO 2768-K
All Dimensions are finished dimensions post surface treatment

METTLER TOLEDO
Drawn Binbin 14-June-2024
Change - - - - - Format A3

Title SLL210 Plate Kit
Refer to protection notice ISO 16016
ERP Number **30966580** ERP Revision

Design Rev A Status Released Units MM 1/1

REV / CHG	ZONE	DESCRIPTION	BY	APPVD	AGENCY	E.R. NO.	DATE
A			Binbin	Bingzheng			2024.06
RECORD OF CHANGES							