

METTLER TOLEDO

Table of Contents

1	Introduction	5
1.1	Document purpose	5
1.2	Further documents and information	5
1.3	Explanation of conventions and symbols used	5
1.4	Acronyms and abbreviations	6
1.5	Product range	6
1.5.1	MA analytical balances	6
1.5.2	MA precision balances, small	7
1.5.3	MA precision balances, large	7
1.5.4	MA precision balances, compact	8
2	Safety Information	9
2.1	Definition of signal words and warning symbols	9
2.2	Product-specific safety notes	9
3	Design and Function	11
3.1	Overview analytical balances	11
3.2	Overview precision balances, small	11
3.3	Overview precision balances, large	12
3.4	Overview precision balances, compact	12
3.5	Overview terminal	13
3.6	Overview interface connections	14
3.7	Components description	15
3.7.1	Draft shield	15
3.7.2	Weighing pan	15
3.7.3	Drip tray	15
3.7.4	Door handle	15
3.7.5	Leveling feet	16
3.7.6	Terminal	16
3.7.7	QuickLock for doors and front panel	16
3.7.8	Release button for back panel	16
3.8	Overview type label	17
3.9	User interface	17
3.9.1	Main sections at a glance	17
3.9.2	Main weighing screen	17
4	Installation and Putting into Operation	20
4.1	Selecting the location	20
4.2	Unpacking the balance	20
4.3	Installation	21
4.3.1	Balances with draft shield	21
4.3.2	Balances without draft shield	24
4.3.3	Balances, large	24
4.3.4	Balances, compact	24
4.4	Putting into operation	25
4.4.1	Connecting the balance	25
4.4.2	Switching on the balance	25
4.4.3	Leveling the balance	25
4.4.3.1	Leveling large balances	26
4.4.3.2	Leveling compact balances	26
4.4.3.3	Leveling all other balances	27
4.4.4	Performing an internal adjustment	27
4.4.5	Entering / Exiting standby mode	27
4.4.6	Entering / Exiting hibernation mode	28
4.4.7	Switching off the balance	28

4.5	Performing a simple weighing	28
4.5.1	Opening and closing draft shield doors	28
4.5.2	Zeroing the balance.....	28
4.5.3	Taring the balance	29
4.5.4	Performing a weighing	29
4.6	Using batteries (compact balance).....	29
4.6.1	Inserting or replacing batteries.....	29
4.7	Transporting, packing, and storing.....	30
4.7.1	Transporting the balance over short distances.....	30
4.7.2	Transporting the balance over long distances.....	30
4.7.3	Packing and storing.....	31
4.8	Weighing below the balance.....	31
<hr/>		
5	Operation	32
5.1	Weighing applications	32
5.1.1	Weighing applications overview	32
5.1.2	Application "Weighing"	32
5.1.3	Application "Piece Counting"	33
5.1.4	Application "Percent weighing"	34
5.1.5	Application "Formulation".....	36
5.1.6	Application "Dynamic Weighing"	37
5.1.7	Application "Density"	38
5.1.7.1	Determining the density of solids	38
5.1.7.2	Formulas used to calculate density	39
5.1.8	Application "Check weighing"	40
5.1.9	Application "Factor weighing"	42
5.1.10	Application "Statistics"	43
5.1.11	Application "Totaling"	44
5.2	Using a sample ID.....	44
5.3	Adjustments.....	45
5.4	Devices / Printers	45
5.4.1	Printer	45
5.4.1.1	Installing a printer through USB	46
5.4.1.2	Installing a printer through RS232	46
5.4.2	Foot switch	46
5.4.3	Auxiliary display	47
5.4.4	Exporting data to a USB storage device	48
5.5	Services	49
5.5.1	PC-Direct function	49
5.6	Passcode protection	50
5.7	Recall weight.....	51
5.8	Exporting data to a USB storage device.....	51
<hr/>		
6	Software Description	53
6.1	Menu navigation	53
6.2	Menu entries.....	53
6.3	Application settings	54
6.3.1	Settings: Weighing	54
6.3.2	Settings: Piece Counting	55
6.3.3	Settings: Percent Weighing.....	55
6.3.4	Settings: Dynamic Weighing	55
6.3.5	Settings: Density	56
6.3.6	Settings: Check Weighing	56
6.3.7	Settings: Factor weighing	57
6.4	Balance settings.....	57
6.5	Balance information	63
6.6	Adjustment settings	64

7	Maintenance	65
7.1	Maintenance tasks	65
7.2	Cleaning	65
7.2.1	Disassembling for cleaning	65
7.2.1.1	Balances with draft shield	65
7.2.1.2	Balances without draft shield.....	68
7.2.1.3	Balances, large	68
7.2.1.4	Balances, compact	69
7.2.2	Cleaning agents.....	69
7.2.3	Cleaning the balance.....	70
7.2.4	Putting into operation after cleaning	71
7.3	Service.....	71
7.4	Software update	71
7.4.1	Updating the software.....	71
7.4.2	Putting into operation after software update.....	72
8	Troubleshooting	73
8.1	Error messages.....	73
8.2	Error symptoms	75
8.3	Putting into operation after fixing an error	77
9	Technical Data	78
9.1	General data.....	78
9.2	Materials.....	79
9.3	Model-specific data	80
9.3.1	Analytical balances, readability 0.01 mg or 0.1 mg	80
9.3.2	Precision balances, readability 1 mg	83
9.3.3	Precision balances, readability 0.01 g or 0.1 g.....	85
9.3.4	Precision balances, large.....	89
9.3.5	Precision balances, compact	90
9.4	Dimensions.....	92
9.4.1	MA analytical balances, readability 0.01 mg	92
9.4.2	MA analytical balances, readability 0.1 mg	93
9.4.3	MA precision balances, small, readability 1 mg	94
9.4.4	MA precision balances, small, readability 0.01 g / 0.1 g	95
9.4.5	MA precision balances, large, readability 0.1 g / 1 g	96
9.4.6	MA precision balances, compact, readability 0.01 g / 0.1 g	97
10	Accessories and Spare Parts	98
10.1	Accessories	98
10.2	Spare parts.....	102
10.2.1	MA analytical balances, readability 0.01 mg	102
10.2.2	MA analytical balances, readability 0.1 mg	103
10.2.3	MA precision balances, small, readability 1 mg	104
10.2.4	MA precision balances, small, readability 0.01 g / 0.1 g	105
10.2.5	MA precision balances, large, readability 0.1 g / 1 g	106
10.2.6	MA precision balances, compact, readability 0.01 g / 0.1 g	107
10.2.7	AC/DC adapter, universal	108
10.2.8	Packaging	109
10.2.8.1	Balances with draft shield	109
10.2.8.2	Balances without draft shield.....	110
10.2.8.3	Balances, large	110
10.2.8.4	Balances, compact	111

11	Disposal	112
12	Compliance Information	113
	Index	115

1 Introduction

Thank you for choosing a METTLER TOLEDO balance. The balance combines high performance with ease of use.

This document is based on the software version V 1.2.

EULA

The software in this product is licensed under the METTLER TOLEDO End User License Agreement (EULA) for Software.

When using this product you agree to the terms of the EULA.

▶ www.mt.com/EULA

1.1 Document purpose

This Reference Manual provides detailed instructions on how to use the instrument.

1.2 Further documents and information

This document is available in other languages online.



▶ www.mt.com/MA-RM

Product page:

▶ www.mt.com/MA-balances

Instructions for cleaning a balance, "8 Steps to a Clean Balance":

▶ www.mt.com/lab-cleaning-guide

Search for software:

▶ www.mt.com/labweighing-software-download

Search for documents:

▶ www.mt.com/library

For further questions, please contact your authorized METTLER TOLEDO dealer or service representative.

▶ www.mt.com/contact

1.3 Explanation of conventions and symbols used

Conventions and symbols

Key and/or button designations and display texts are shown in graphic or bold text, e.g.,  **Publish**.

 **Note** For useful information about the product.



Refers to an external document.

Elements of instructions

In this manual, step-by-step instructions are presented as follows. The action steps are numbered and can contain prerequisites, intermediate results and results, as shown in the example. Sequences with less than two steps are not numbered.

- Prerequisites that must be fulfilled before the individual steps can be executed.

1 Step 1

➔ Intermediate result

2 Step 2

➔ Result

1.4 Acronyms and abbreviations



Original term	Explanation
ABS/PC	Acrylonitrile butadiene styrene / polycarbonate (polymer blend)
AC	Alternating Current
ASTM	American Society for Testing and Materials
DC	Direct Current
EMC	Electromagnetic Compatibility
FCC	Federal Communications Commission
GWP	Good Weighing Practice
ID	Identification
IP	Ingress Protection
LPS	Limited Power Source
MT-SICS	METTLER TOLEDO Standard Interface Command Set
NA	Not Applicable
OIML	Organisation Internationale de Métrologie Légale (International Organization of Legal Metrology)
PA 12	Polyamid 12
PBT	Polybutylene terephthalate
PET	Polyethylene terephthalate
POM	Polyoxymethylene
RM	Reference Manual
SOP	Standard Operating Procedure
TDNR	Type Definition Number
TPE	Thermoplastic elastomer
UM	User Manual
USB	Universal Serial Bus
USP	United States Pharmacopeia

1.5 Product range

1.5.1 MA analytical balances

Balance	Models designation
	Readability: 0.01 mg <ul style="list-style-type: none">• MA55• MA95• MA155DU
	Readability: 0.1 mg <ul style="list-style-type: none">• MA54• MA54E• MA104• MA104E• MA204• MA204E

1.5.2 MA precision balances, small

Balance	Models designation
	Readability: 1 mg <ul style="list-style-type: none"> • MA103 • MA103E • MA203 • MA203E • MA303 • MA303E • MA503 • MA503E
	Readability: 0.01 g <ul style="list-style-type: none"> • MA602 • MA602E • MA1002 • MA1002E • MA2002 • MA2002E • MA3002 • MA3002E • MA4002 • MA4002E • MA6002 • MA6002E
	Readability: 0.1 g <ul style="list-style-type: none"> • MA5001 • MA5001E

1.5.3 MA precision balances, large

Balance	Models designation
	Readability: 0.1 g <ul style="list-style-type: none"> • MA12001L • MA16001L • MA32001L
	Readability: 1 g <ul style="list-style-type: none"> • MA32000L

1.5.4 MA precision balances, compact

Balance	Models designation
	Readability: 0.01 g <ul style="list-style-type: none">• MA602P• MA602PE• MA2002P• MA2002PE
	Readability: 0.1 g <ul style="list-style-type: none">• MA6001P• MA6001PE

2 Safety Information

Two documents named "User Manual" and "Reference Manual" are available for this instrument.

- The User Manual is available online in various languages.
- A printed version of the User Manual is delivered with the instrument.
- The Reference Manual is available online. This manual contains a full description of the instrument and its use.
- Keep both documents for future reference.
- Include both documents if you transfer the instrument to other parties.

Only use the instrument according to the User Manual and the Reference Manual. If you do not use the instrument according to these documents or if the instrument is modified, the safety of the instrument may be impaired and Mettler-Toledo GmbH assumes no liability.

2.1 Definition of signal words and warning symbols

Safety notes contain important information on safety issues. Ignoring the safety notes may lead to personal injury, damage to the instrument, malfunctions and false results. Safety notes are marked with the following signal words and warning symbols:

Signal words

DANGER	A hazardous situation with high risk, resulting in death or severe injury if not avoided.
WARNING	A hazardous situation with medium risk, possibly resulting in death or severe injury if not avoided.
CAUTION	A hazardous situation with low risk, resulting in minor or moderate injury if not avoided.
NOTICE	A hazardous situation with low risk, resulting in damage to the instrument, other material damage, malfunctions and erroneous results, or loss of data.

Warning symbols



General hazard



Notice

2.2 Product-specific safety notes

Intended use

This instrument is designed to be used by trained staff. The instrument is intended for weighing purposes.

Any other type of use and operation beyond the limits of use stated by Mettler-Toledo GmbH without consent from Mettler-Toledo GmbH is considered as not intended.

Responsibilities of the instrument owner

The instrument owner is the person holding the legal title to the instrument and who uses the instrument or authorizes any person to use it, or the person who is deemed by law to be the operator of the instrument. The instrument owner is responsible for the safety of all users of the instrument and third parties.

Mettler-Toledo GmbH assumes that the instrument owner trains users to safely use the instrument in their workplace and deal with potential hazards. Mettler-Toledo GmbH assumes that the instrument owner provides the necessary protective gear.

Safety notes



WARNING

Death or serious injury due to electric shock

Contact with parts that carry a live current can lead to death or injury.

- 1 Only use the METTLER TOLEDO power cable and AC/DC adapter designed for your instrument.
- 2 Connect the power cable to a grounded power outlet.
- 3 Keep all electrical cables and connections away from liquids and moisture.
- 4 Check the cables and the power plug for damage and replace them if damaged.



NOTICE

Damage to the instrument or malfunction due to the use of unsuitable parts

- Only use parts from METTLER TOLEDO that are intended to be used with your instrument.

3 Design and Function

3.1 Overview analytical balances

0.01 mg / 0.1 mg

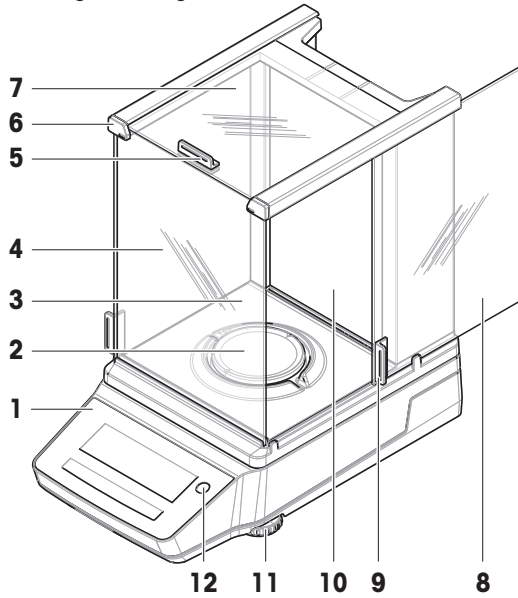

1	Terminal	7	Top door, draft shield
2	Weighing pan	8	Side door, draft shield (right/left)
3	Drip tray	9	Handle, side door
4	Front panel, draft shield	10	Back panel, draft shield
5	Handle, top door	11	Leveling feet
6	QuickLock, front panel	12	Level indicator

3.2 Overview precision balances, small

1 mg

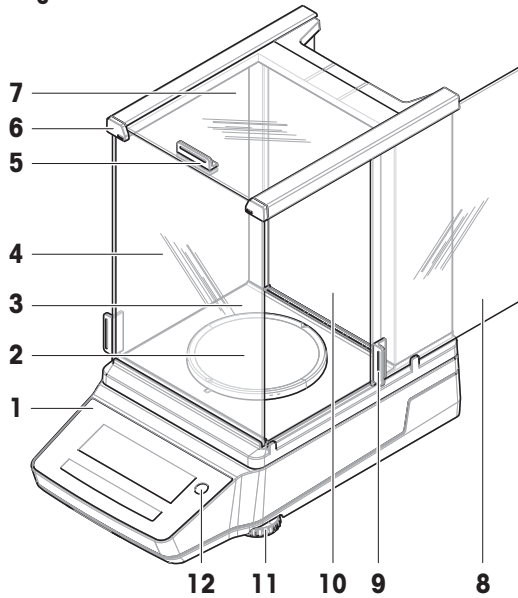

0.01 g / 0.1 g

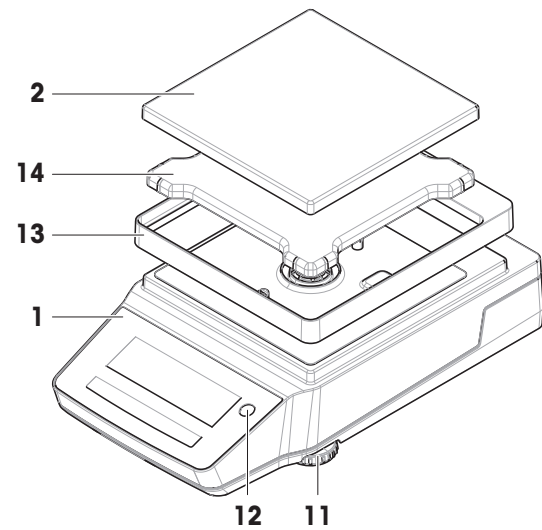

1	Terminal	8	Side door, draft shield (right/left)
2	Weighing pan	9	Handle, side door
3	Drip tray	10	Back panel, draft shield
4	Front panel, draft shield	11	Leveling feet
5	Handle, top door	12	Level indicator
6	QuickLock, front panel	13	Draft-protection element
7	Top door, draft shield	14	Weighing pan support

3.3 Overview precision balances, large

0.1 g / 1 g

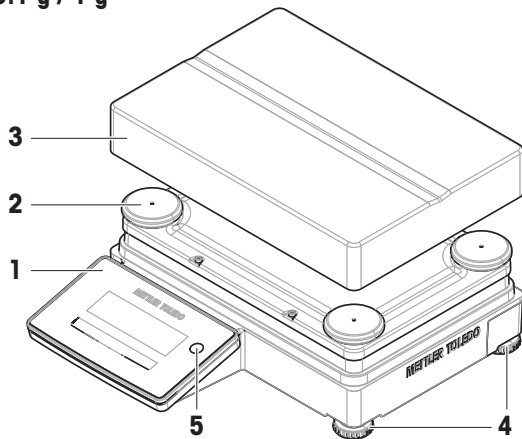

1	Terminal	4	Leveling feet
2	Weighing pan support cap	5	Level indicator
3	Weighing pan		

3.4 Overview precision balances, compact

0.01 g / 0.1 g

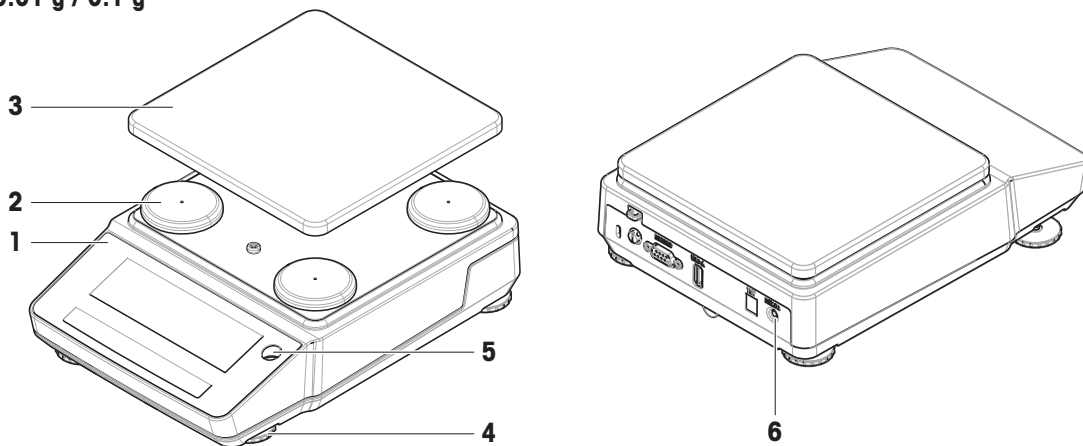

1	Terminal	4	Leveling feet
2	Weighing pan support cap	5	Level indicator
3	Weighing pan	6	Wake-up switch (battery mode)



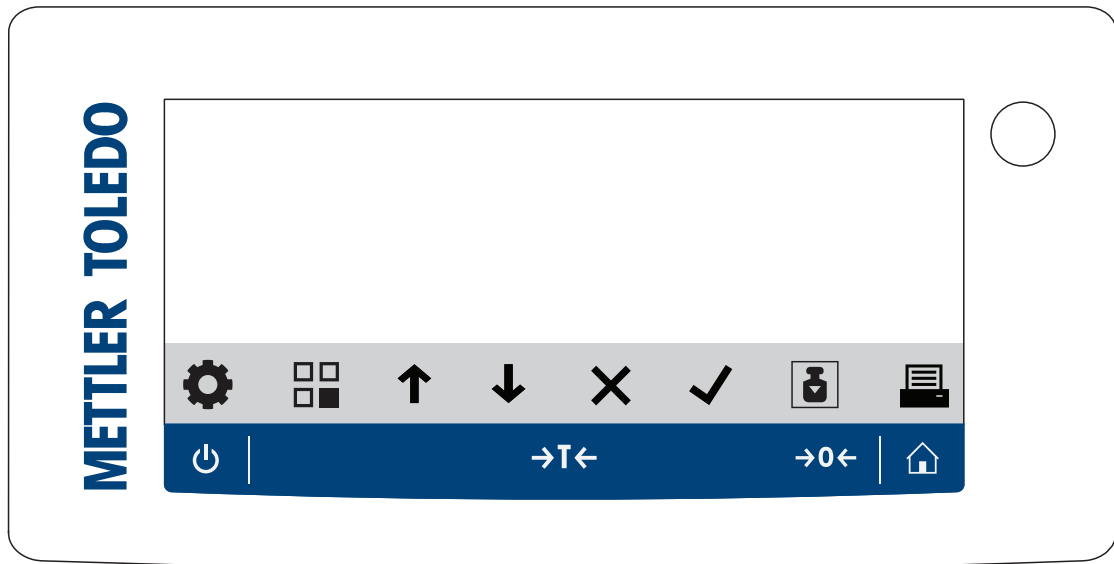





3.5 Overview terminal



Terminal keys

	Name	Description
	Standby	By tapping , the balance is not completely switched off but goes into standby mode. To switch the balance completely off, it must be unplugged from the power supply. Note Do not disconnect the balance from the power supply unless the balance is not used for an extended period of time. After switching on the instrument, it must warm up before giving accurate results. Note Compact balances in battery mode only: By tapping , the balance is completely switched off. There is no standby mode.
	Tare	Tares the balance. This function is used when the weighing process involves containers. After taring the balance, the screen shows ^{Net} which indicates that all displayed weights are net.
	Zero	Zeroes the balance. The balance must always be zeroed before starting the weighing process. After zeroing, the balance sets a new zero point.
	Home	To return from any settings menu level to the main weighing screen of the currently set or last used application.

Operation keys

	Name	Description
	Settings	Accesses the settings menu.
	Applications	Accesses the applications menu.
	Previous / Up / Increase	<ul style="list-style-type: none"> • Scrolls up in a list of topics. • Changes between unit 1, unit 2, and the application unit (if available). • Increases numbers. • Adds a captured weight within an application.
	Next / Down / Decrease	<ul style="list-style-type: none"> • Scrolls down in a list of topics. • Changes between unit 1, unit 2, and the application unit (if available). • Decreases numbers.
	Cancel	<ul style="list-style-type: none"> • Cancels a task or leaves the menu without saving. • Discards a sample in a workflow application.
	Accept	<ul style="list-style-type: none"> • Accesses the selected menu. • Starts the selected application. • Confirms the entry.
	Adjustment	Executes the predefined adjustment procedure.
	Print / Transfer	<ul style="list-style-type: none"> • Prints the displayed value. • Transfers data to the predefined target location.

3.6 Overview interface connections

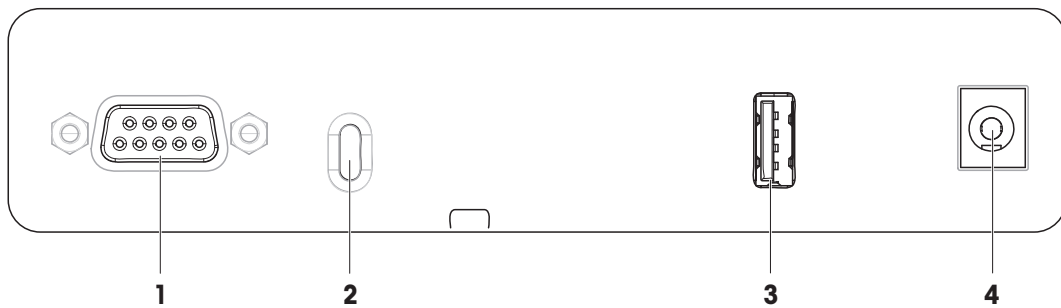

1	RS232C serial interface	3	USB-A port
2	Slot for anti-theft cable	4	Socket for AC/DC adapter

3.7 Components description

3.7.1 Draft shield

The draft shield protects the weighing area against environmental impacts like drafts or moisture. The side doors and the top door can be opened manually.

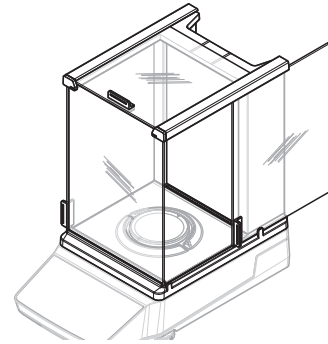

3.7.2 Weighing pan

The weighing pan is the load receptor that serves to accommodate the weighing item.

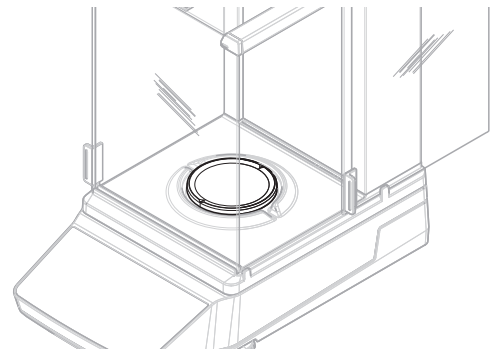

3.7.3 Drip tray

The drip tray is positioned below the weighing pan. The primary purpose of the drip tray is to ensure quick cleaning of the balance.

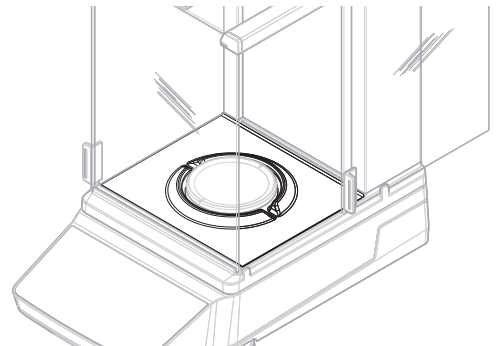

3.7.4 Door handle

The door handles are mounted on the draft shield doors. The handles are used to manually open the side doors and the top door of the draft shield.

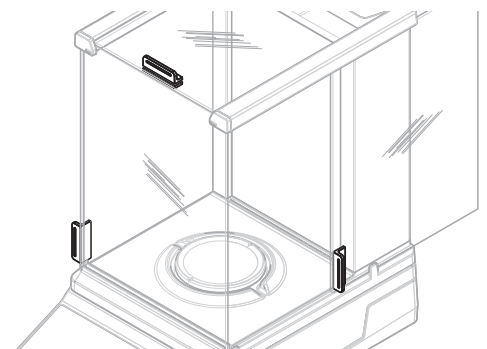

3.7.5 Leveling feet

The balance stands on height-adjustable feet. These feet are used to level the balance.

Note

Large balances and compact balances have four leveling feet.

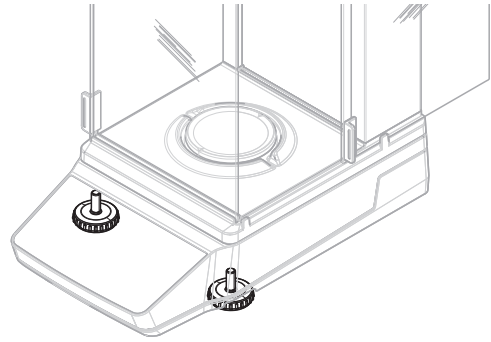

3.7.6 Terminal

The terminal is integrated into the balance and has an LCD display. The terminal and the platform are protected by a replaceable cover.

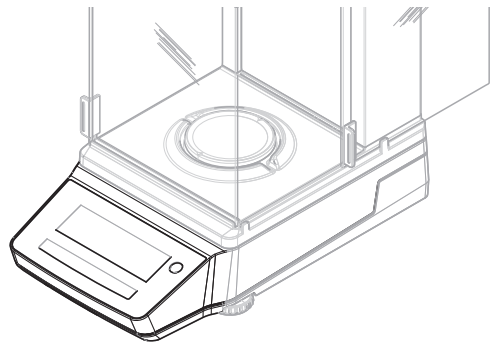

3.7.7 QuickLock for doors and front panel

Depending on the position, the QuickLock is used to lock/unlock the top door, the side doors, and the front panel of the draft shield.

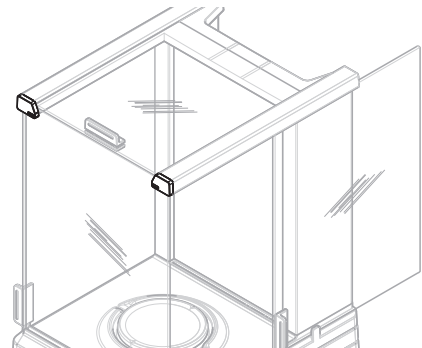

3.7.8 Release button for back panel

The release button is used to lock/unlock the back panel of the draft shield.

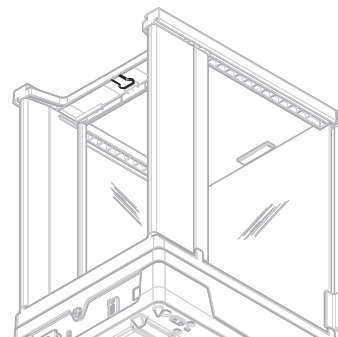

3.8 Overview type label

The information on the type label helps to identify the balance.



1	Balance model	5	Manufacturer
2	Year of manufacture	6	Balance serial number
3	Maximum capacity	7	Power consumption
4	Readability		

3.9 User interface

3.9.1 Main sections at a glance

The main weighing screen (1) displays weighing results and provides feedback on the status of the balance.



	Name	Description
1	Main weighing screen	Displays the weighing results and provides information on the status of the balance.

See also





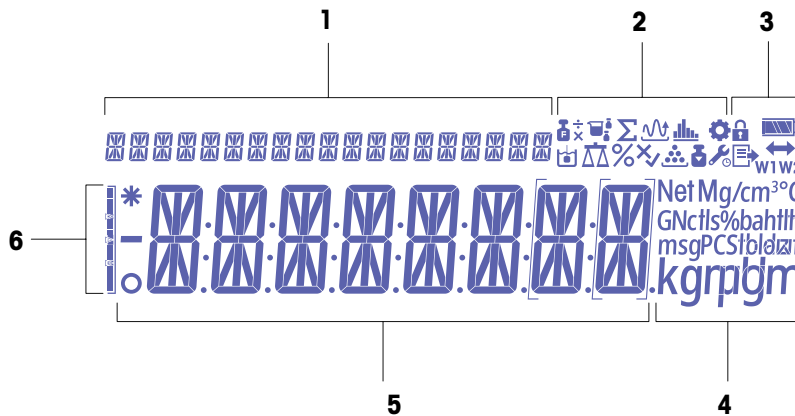





[Main weighing screen](#) ▶ Page 17

3.9.2 Main weighing screen















1	Coach text	4	Unit icons
2	Application icons	5	Weight value / menu label / parameter label / parameter value
3	Status icons	6	Weighing aid

Application icons

	Name	Description
	Application "Weighing"	The application "Weighing" is used for simple weighing tasks.
	Application "Piece counting"	The application "Piece counting" allows you to determine the number of pieces put on the weighing pan.
	Application "Percent weighing"	"Percent weighing" allows a sample weight to be checked as a percentage of a reference target weight
	Application "Formulation"	The application "Formulation" (Net total) has several purposes. <ul style="list-style-type: none"> • Weigh in (add and store) up to 999 individual component weights and display the total. If a printer is connected, the component weights are printed individually and as a total. • Tare and store up to 999 container weights and display the total. If a printer is connected, the tare weights are printed individually and as a total. • Fill up the sum of all component net weight values by adding a further component to a higher value.
	Application "Dynamic weighing"	The application "Dynamic weighing" allows you to determine the weights of unstable samples or to determine weights under unstable ambient conditions. The balance calculates the weight as the average of a number of weighing operations over a defined time.
	Application "Density"	The application "Density" allows you to determine the density of solid bodies. Determination of the density uses "Archimedes' principle" according to which a body immersed in a fluid undergoes an apparent loss in weight which is equal to the weight of the fluid it displaces.
	Application "Check weighing"	The application "Check weighing" allows you to check the deviation of a sample weight within a tolerance limit to a reference target weight.
	Application "Factor weighing"	The application "Factor weighing" multiplies a predefined factor by the weight value (in grams) or divides the weight value by a predefined factor. Depending on the method used, one of the following equations applies: <ul style="list-style-type: none"> • result = weight / factor • result = weight × factor • result = weight + factor • result = weight – factor The result is rounded to a predefined number of decimal places.
	Application "Statistics"	The application "Statistics" allows you to generate statistics of a series of weighing values. 1 to 999 values are possible.
	Application "Totaling"	The application "Totaling" allows you to weigh in different samples to add their weight values and to totalize them. 1 to 999 samples are possible.

Status icons

	Name	Description
	In the menu "Settings"	The Menu settings is open and an entry of this menu can be selected.

	Name	Description
	Access protection on	Menu settings are locked and cannot be adapted.
	Adjustments started	The internal or external adjustment of the balance has started.
	Service reminder	<ul style="list-style-type: none"> • Icon is blinking: next service is due. • Icon lights up constantly: service mode is active.
	Publishing	Data is being published. If this icon is displayed, it is not possible to start a new data transfer.
	Status of battery charge	Compact balances only: Indicates the level of the battery charge. <ul style="list-style-type: none"> • : Battery full • : Battery 3/4 full • : Battery 1/2 full • : Battery 1/4 full • : Battery discharged
	Connectivity	Data connection to a USB device.
W1	Weighing range 1	Weighing range 1 is active.
W2	Weighing range 2	Weighing range 2 is active.
Net	Net weight values	"Net" indicates that all weight values displayed are net values.
G	Gross weight values	Gross weight values are displayed.
M	Stored value (Memory)	A stored value from the memory of the balance is displayed.
X	Failed operation	An operation has not been completed successfully.

Label Icons

	Name	Description
-	Negative value	Indicates that the displayed values are negative.
*	Calculated value	Indicates that the displayed value is calculated.
o	Unstable value	Indicates the displayed value is unstable, meaning that it changes over time.
[]	Uncertified digits	Brackets indicate uncertified digits (approved balance models only). <ul style="list-style-type: none"> • []: First decimal place. • []: First decimal place for dual range balance.

4 Installation and Putting into Operation

4.1 Selecting the location

A balance is a sensitive precision instrument. The location where it is placed will have a profound effect on the accuracy of the weighing results.

Requirements of the location

Place indoors on stable table



Avoid direct sunlight

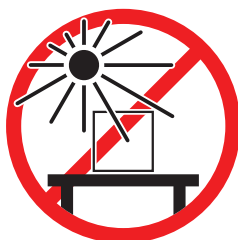

Ensure sufficient spacing

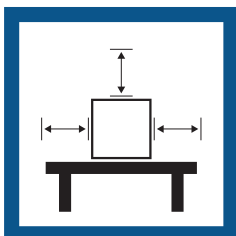

Avoid vibrations



Level the instrument



Avoid strong drafts



Provide adequate lighting

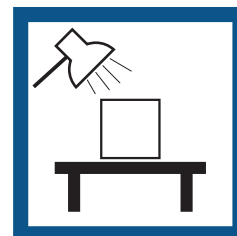

Avoid temperature fluctuations



Take into account the environmental conditions. See "Technical Data".

Sufficient spacing for balances: > 15 cm all around the instrument

4.2 Unpacking the balance

Check the package, the packaging elements and the delivered components for damages. If any components are damaged, please contact your METTLER TOLEDO service representative.

Note

Depending on the balance model, the packaging elements and the components may look different.

- 1 Open the box and lift the package out using the lifting strap (1).
- 2 Place the package on a level surface with the inscription **BOTTOM** (2) facing downwards.

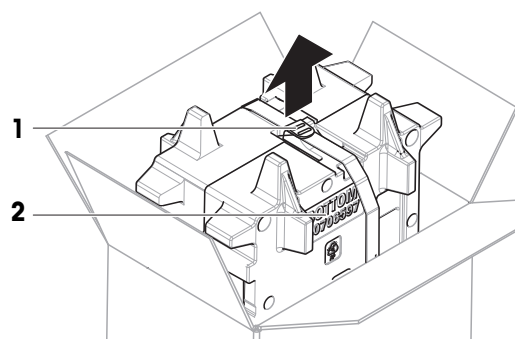

- 3 Open the lifting strap (1) and remove the User Manual (3).

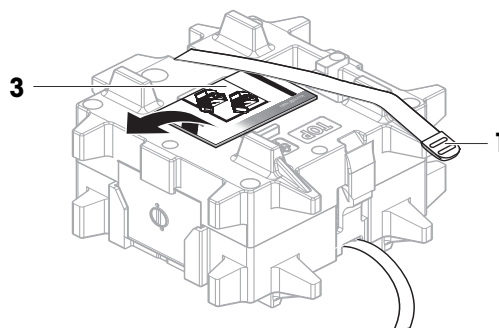

- 4 Remove the upper part of the package and unpack the drip tray (4).

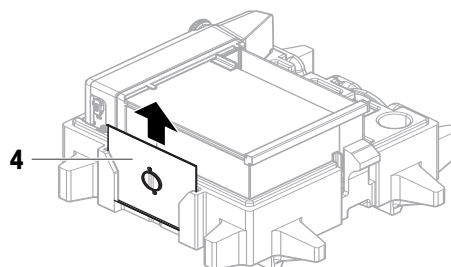

- 5 Carefully unpack the balance (5) and all other items.
- 6 Remove the protective bag.
- 7 Keep the protective cover installed on the platform and on the terminal.
- 8 Store all parts of the packaging in a safe place for future use.
 - ➔ The balance is ready for installation.

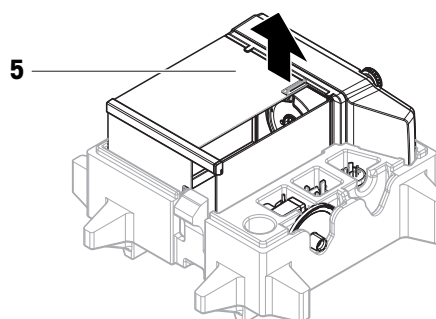

4.3 Installation

Note

Depending on the balance model, the components may look different.

4.3.1 Balances with draft shield



CAUTION

Injury due to sharp objects or broken glass

Instrument components, e.g., glass, can break and lead to injuries.

- Always proceed with focus and care.

Note

Skip steps 1 – 5 when unpacking the balance for the first time, or if the draft shield is already assembled and mounted on the platform.

- 1 Assemble the draft shield: Turn the QuickLock (**1**, right, left) and slide in the top door (**2**).

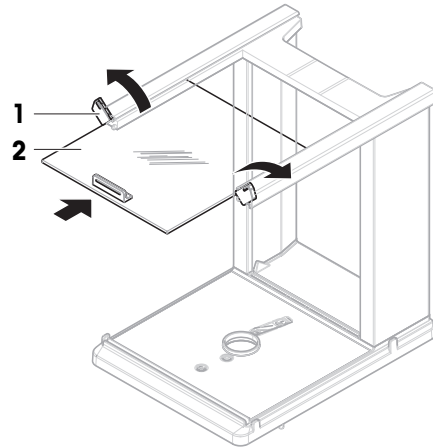

- 2 Slide in the side door (**3**) (right, left).

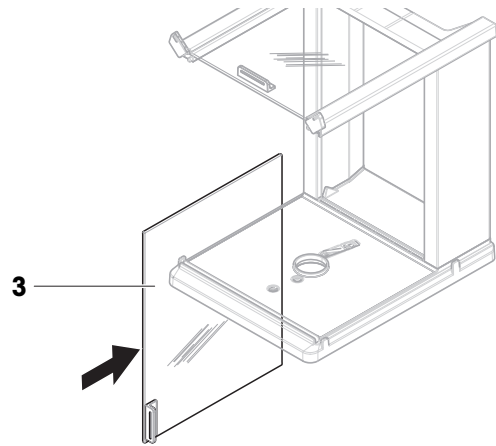

- 3 Attach the front panel (**4**), then turn the QuickLock (**1**, right, left) to hold the panel in place.

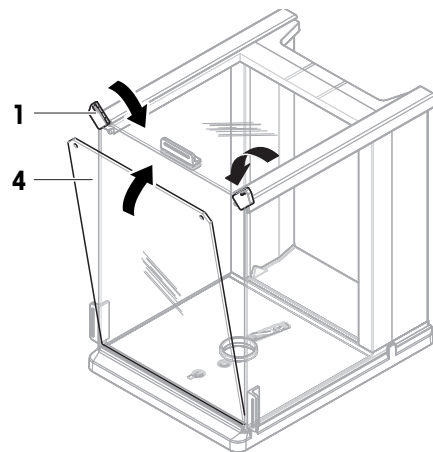

- 4 Attach the back panel (5). Make sure the release button (6) snaps in.

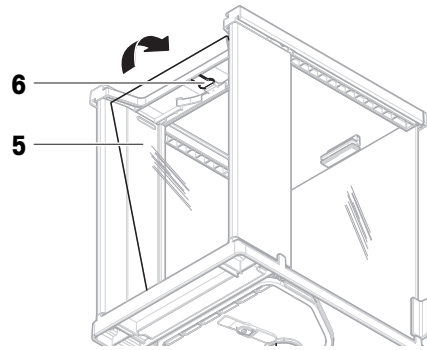

- 5 Secure the draft shield (7) to the platform (8) by fixing the front screw (9) and the rear screw (10) with a Phillips screwdriver.

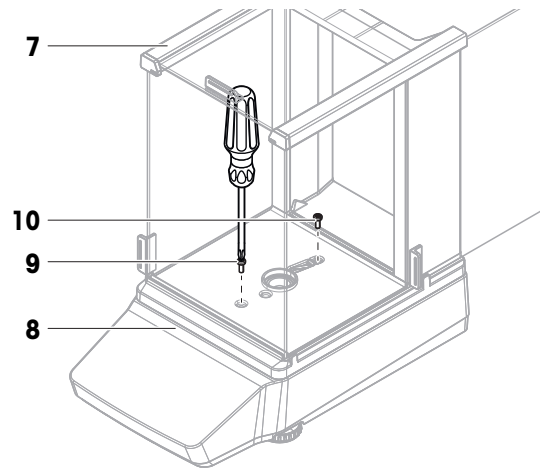

- 6 Fully open the side door (11)
- 7 Insert the drip tray (12).

Note

The ring-shaped elevation (13) must point upwards. It serves as draft protection.

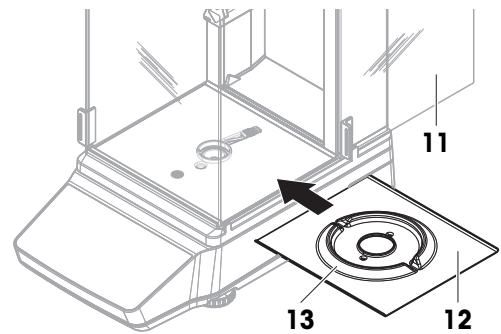

- 8 Install weighing pan (14).
➔ The balance is ready for use.

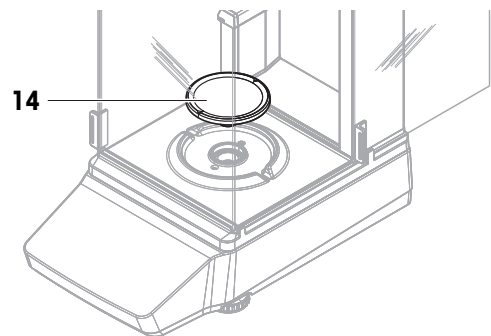

4.3.2 Balances without draft shield

- 1 Place the weighing pan support (1) on top of the platform (2).
- Note**
To protect your balance, keep the protective cover installed on the platform (2).
- 2 Place the weighing pan (3) on top of the weighing pan support (1).
 - 3 Place the draft-protection element (4) on top of the platform (2).
- ➔ The balance is ready for use.

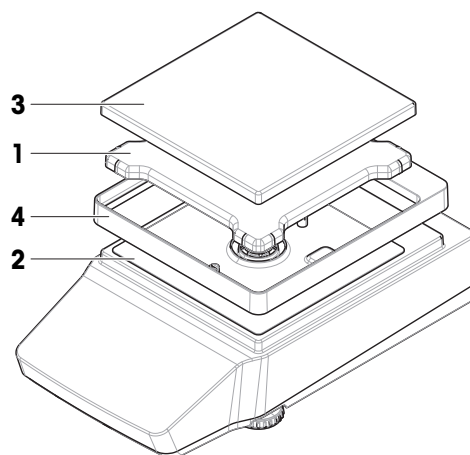

4.3.3 Balances, large

- 1 Remove the transport protection (1).
 - 2 Place the weighing pan (2) on top of the support caps (3).
- Note**
To protect your balance, keep the protective cover installed on the terminal (4).
- ➔ The balance is ready for use.

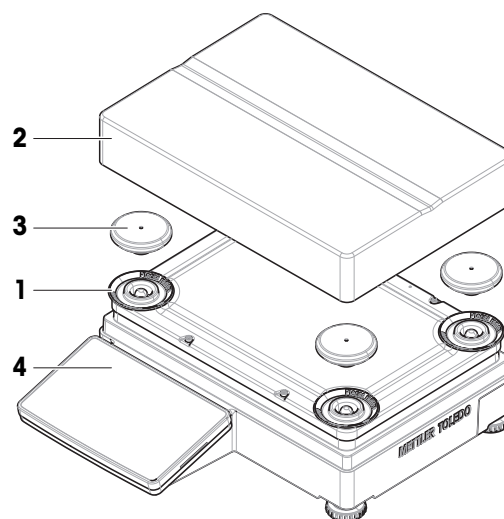

4.3.4 Balances, compact

- 1 Place the weighing pan (1) on top of the support caps (2).
- Note**
To protect your balance, keep the protective cover installed on the platform (3).
- ➔ The balance is ready for use.

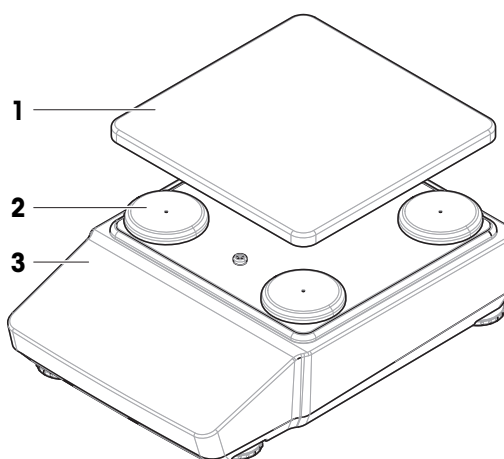

4.4 Putting into operation

4.4.1 Connecting the balance



WARNING

Death or serious injury due to electric shock

Contact with parts that carry a live current can lead to death or injury.

- 1 Only use the METTLER TOLEDO power cable and AC/DC adapter designed for your instrument.
- 2 Connect the power cable to a grounded power outlet.
- 3 Keep all electrical cables and connections away from liquids and moisture.
- 4 Check the cables and the power plug for damage and replace them if damaged.

- 1 Install the cables in such a way that they cannot be damaged or interfere with operation.
- 2 Insert the plug of the AC/DC adapter (1) into the power socket of the instrument.
- 3 Insert the plug of the power cable into a grounded power outlet that is easily accessible.
 - ➔ The balance automatically switches on.

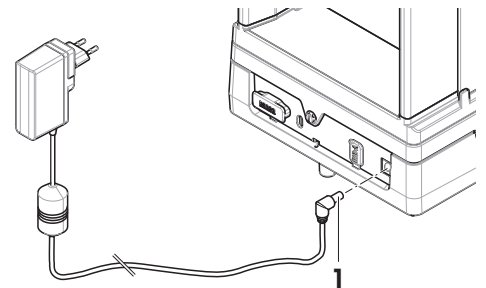

Note

Do not connect the instrument to a power outlet controlled by a switch. After switching on the instrument, it must warm up before giving accurate results.

See also

[General data](#) ▶ Page 78

4.4.2 Switching on the balance

When connected to the power supply, the balance automatically switches on.

Acclimatization and warm up

Before the balance gives reliable results, it must:

- acclimatize to the room temperature
- warm up by being connected to the power supply

The acclimatization time and warm-up time for balances are available in "General data".

Note

When the balance is exiting standby, it is ready immediately.

See also

[General data](#) ▶ Page 78

[Entering / Exiting standby mode](#) ▶ Page 27

[Entering / Exiting hibernation mode](#) ▶ Page 28

[Switching off the balance](#) ▶ Page 28

4.4.3 Leveling the balance

Exact horizontal and stable positioning are essential for repeatable and accurate weighing results.

4.4.3.1 Leveling large balances

- 1 Screw in all leveling feet fully.
- 2 Screw out all leveling feet two to three turns except for the rear left leveling foot.
- 3 Turn the leveling feet (1) until the air bubble is in the center of the level indicator (2). Proceed as shown in the following example.
- 4 Screw out the rear left leveling foot until it makes contact with the table surface.
 - ➔ The balance is leveled and supported by all four leveling feet.

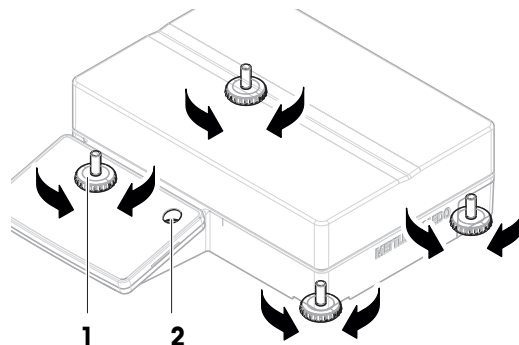

Example

Air bubble at 12 o'clock:



Turn both front feet clockwise.
Turn rear right foot counterclockwise.

Air bubble at 3 o'clock:



Turn left front foot clockwise, turn right front foot counterclockwise.
Turn rear right foot counterclockwise.

Air bubble at 6 o'clock:



Turn both front feet counterclockwise.
Turn rear right foot clockwise.

Air bubble at 9 o'clock:



Turn both front feet counterclockwise.
Turn rear right foot counterclockwise.

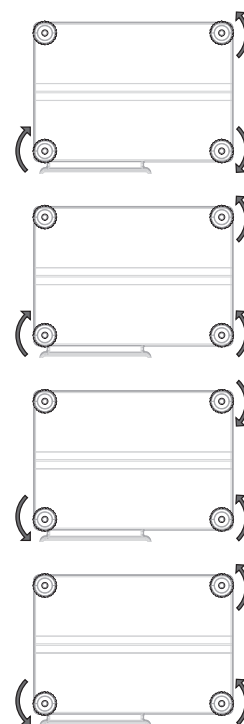

4.4.3.2 Leveling compact balances

- 1 Screw in both rear leveling feet fully.
- 2 Screw out both front leveling feet two to three turns.
- 3 Turn the front leveling feet (1) until the air bubble is in the center of the level indicator (2). Proceed as shown in the following example.
- 4 Screw out both rear leveling feet until they make contact with the table surface.
 - ➔ The balance is leveled and supported by all four leveling feet.

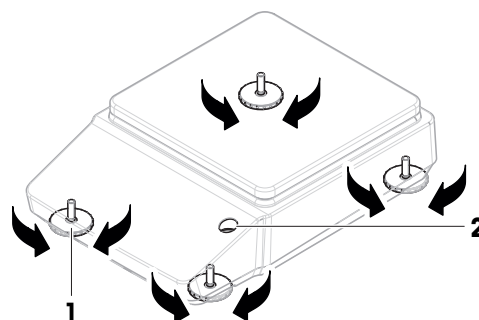

Example

Air bubble at 12 o'clock:



Turn both feet clockwise.



Air bubble at 3 o'clock:



Turn left foot clockwise, turn right foot counterclockwise.



Air bubble at 6 o'clock:



Turn both feet counterclockwise.



Air bubble at 9 o'clock:



Turn left foot counterclockwise, turn right foot clockwise.



4.4.3.3 Leveling all other balances

- Turn the leveling feet (1) until the air bubble is in the center of the level indicator (2).

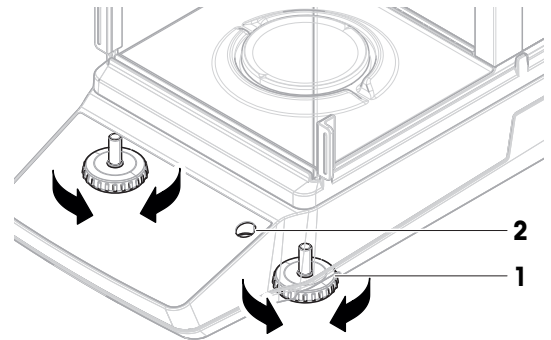

Example

Air bubble at 12 o'clock:



Turn both feet clockwise.



Air bubble at 3 o'clock:



Turn left foot clockwise, turn right foot counterclockwise.



Air bubble at 6 o'clock:



Turn both feet counterclockwise.



Air bubble at 9 o'clock:



Turn left foot counterclockwise, turn right foot clockwise.



4.4.4 Performing an internal adjustment

- 1 On the main weighing screen, press .
 - ➔ ADJ.INT appears.
- 2 Press .
- 3 Press .

4.4.5 Entering / Exiting standby mode

- 1 To enter standby mode, press for less than 2 s.
 - ➔ The brightness of the display is reduced, information on the display is visible. The balance is still switched on.

- 2 To exit standby mode, press .
➔ The display is turned on.

4.4.6 Entering / Exiting hibernation mode

 **Note**

Only relevant for compact balances in battery mode.

- 1 To enter hibernation mode, press  for less than 2 s.
➔ The display is turned off. The balance is in hibernation mode.
- 2 To exit hibernation mode, press the wake-up switch on the rear side of the balance.
➔ The display is turned on.



4.4.7 Switching off the balance

To completely switch off the balance, it must be disconnected from the power supply. By pressing , the balance goes only into standby mode.

 **Note**

When the balance has been completely switched off for some time, it must warm up before it can be used.

See also

-  Switching on the balance ▶ Page 25
-  Entering / Exiting standby mode ▶ Page 27
-  Entering / Exiting hibernation mode ▶ Page 28

4.5 Performing a simple weighing

 **Note**

A balance with draft shield is used to explain the procedure. For balances without a draft shield, skip the instructions steps concerning the draft shield.

4.5.1 Opening and closing draft shield doors

- Open the door manually with the door handle (1).

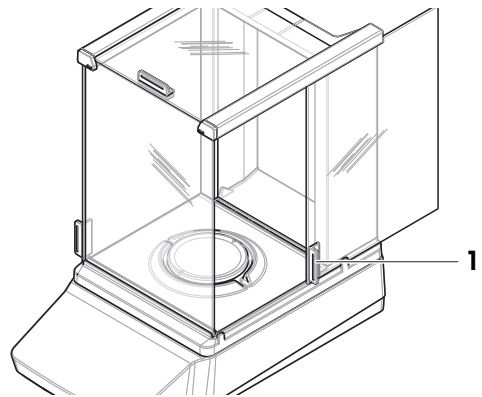

4.5.2 Zeroing the balance

- 1 Open the draft shield.
- 2 Clear the weighing pan.
- 3 Close the draft shield.
- 4 Press  to zero the balance.
➔ The balance is zeroed.

4.5.3 Taring the balance

If a sample vessel is used, the balance must be tared.

- The balance is zeroed.
- 1 Place the sample vessel (1) on the weighing pan (2).
- 2 Close the draft shield door (3).
- 3 Press →T← to tare the balance.
 - ➔ The balance is tared. The icon ^{Net} appears.

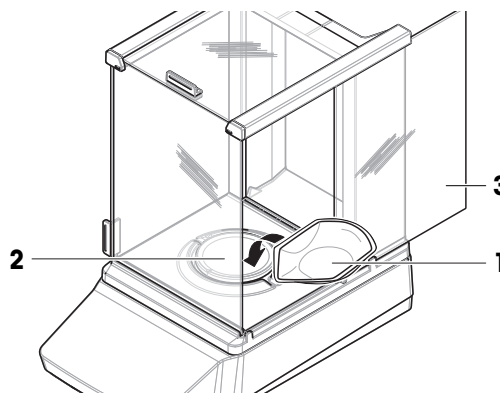

4.5.4 Performing a weighing

- 1 Open the draft shield.
- 2 Place the weighing object into the sample vessel.
- 3 Close the draft shield.
- 4 Wait until the instability detector ○ disappears.
 - ➔ The result is displayed.
- 5 Optional, if a printer is connected: Press to print the weighing result.

4.6 Using batteries (compact balance)

The balance can also be operated with batteries. Under normal operating conditions, the balance runs independently of the AC power supply for about 8 to 15 hours (using alkaline batteries).

Immediately after an interruption of the AC power supply, the balance automatically switches to battery operation. This can happen, for example, by pulling the power plug, or in the event of a power failure. After the AC power supply is restored, the balance automatically switches back to AC operation.

The balance uses eight standard AA batteries (LR6). Alkaline batteries are preferred.

Rechargeable batteries can be used. Charging batteries inside the balance is **not** possible.

When the balance is operated with batteries, the battery symbol in the display lights up. The number of segments that are shown in the battery symbol indicate the charge level. When the batteries are almost completely discharged, the battery symbol flashes.

See also

Main weighing screen ▶ Page 17

4.6.1 Inserting or replacing batteries

- Read and follow all warnings and instructions supplied by the battery manufacturer.
- Do not mix different types or brands of batteries. Performance of batteries varies depending on the manufacturer.
- Remove the batteries from the balance if the balance is not used for a long period of time.
- Batteries must be disposed of properly, according to local regulations.

Proceed as follows:

- The balance is switched off.
- The weighing pan is removed.
- 1 Turn the balance carefully on its side.

- 2 Open and remove the battery-chamber cover.
- 3 Insert / replace the batteries with the correct polarity as shown in the battery holder.
- 4 Insert and close the battery-chamber cover.
- 5 Turn the balance carefully to its normal position.
- 6 Reinstall all components in the reverse order.

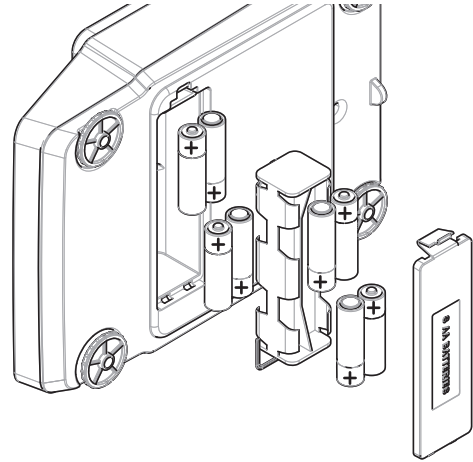

4.7 Transporting, packing, and storing

4.7.1 Transporting the balance over short distances

- 1 Disconnect the AC/DC adapter and unplug all interface cables.
- 2 Hold the balance with both hands and carry it in horizontal position to the target location. Consider the requirements of the location.

If you want to put the balance into operation, proceed as follows:

- 1 Connect in reverse order.
- 2 Give the balance sufficient time to warm up.
- 3 Level the balance.
- 4 Perform an internal adjustment.

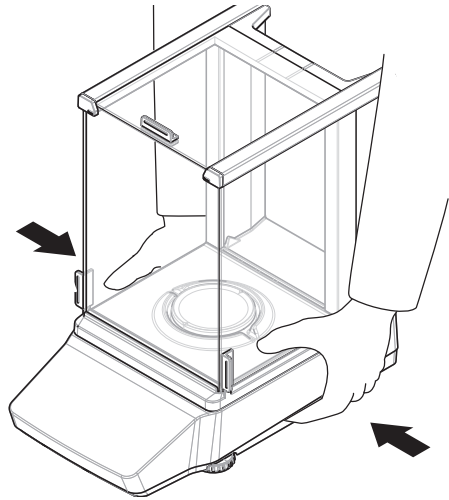

See also

- [Selecting the location ▶ Page 20](#)
- [Switching on the balance ▶ Page 25](#)
- [Leveling the balance ▶ Page 25](#)
- [Performing an internal adjustment ▶ Page 27](#)

4.7.2 Transporting the balance over long distances

METTLER TOLEDO recommends using the original packaging for transportation or shipment of the balance or balance components over long distances. The elements of the original packaging are developed specifically for the balance and its components and ensure maximum protection during transportation.

See also

- [Unpacking the balance ▶ Page 20](#)

4.7.3 Packing and storing

Packing the balance

Store all parts of packaging in a safe place. The elements of the original packaging are developed specifically for the balance and its components, and ensures maximum protection during transportation and storage.

Storing the balance

Only store the balance under the following conditions:

- Indoor and in the original packaging
- According to the environmental conditions, see "Technical Data"

Note

When storing for longer than two weeks, the battery (capacitor) may become empty (only date and time get lost).

See also

 [Technical Data](#) ▶ Page 78

4.8 Weighing below the balance

Your balance is equipped with a weighing hook for performing weighing operations below the work surface (weighing below the balance).

- A weighing table or workbench is available, through which the weighing hook can be accessed.
 - 1 Disconnect the balance from the AC/DC adapter.
 - 2 Disconnect all interface cables.
 - 3 Carefully tilt the balance to its side.
 - 4 Remove the weighing hook cover (1) that is closer to the front of the balance.
 - ➔ The hook (2) is accessible.
 - 5 Carefully put the balance back on its feet.
 - 6 Reconnect the AC/DC adapter and the interface cables.
 - ➔ The weighing hook is accessible and can be used for below-the-balance weighing.

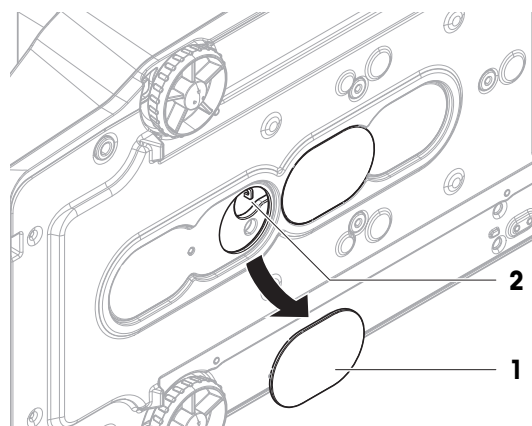

See also

 [Dimensions](#) ▶ Page 92





5 Operation

5.1 Weighing applications











A weighing application serves to carry out specific weighing tasks. The balance offers various weighing applications with default parameters.

5.1.1 Weighing applications overview

This section serves to select a weighing application for a specific weighing procedure.

- 1 Tap  to enter the applications menu.
→ CHOOSE APPLICATION is displayed.
- 2 Tap  or  to navigate between different applications.
- 3 Tap  to confirm your selection.







The following weighing applications are available:

-  "Weighing"
-  "Counting"
-  "Percent weighing"
-  "Formulation"
-  "Dynamic weighing"
-  "Density"
-  "Check weighing"
-  "Factor weighing"
-  "Statistics"
-  "Totaling"

5.1.2 Application "Weighing"

The application WEIGHING offers basic weighing functions. This application is used for simple weighing tasks. The settings of the weighing item, such as target weight and tolerances, can be specified.

Example procedure

- 1 Press  to enter the applications menu.
→ CHOOSE APPLICATION is displayed.
- 2 Press  or  to select the application WEIGHING.
- 3 Press  to confirm your selection.
→ The icon  WEIGHING. is displayed and the corresponding weighing application opens.
- 4 Press  to zero the balance.
- 5 Open the draft shield door (if applicable).
- 6 Place the weighing object (1) on the weighing pan (2).
- 7 Close the draft shield door (if applicable).
- 8 Wait until the weight stabilizes.
→ The result is displayed.
- 9 Optional, depending on the settings: Press  PUBLISH to print or export the weighing result.

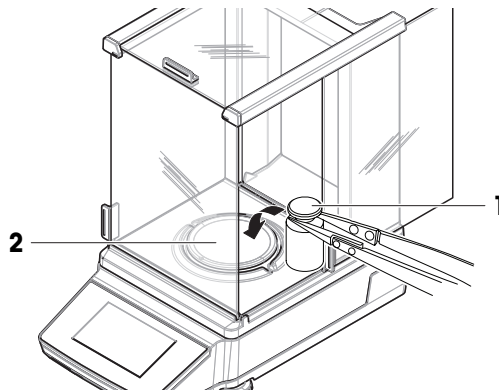

5.1.3 Application "Piece Counting"

The application "Piece counting" allows you to determine the number of pieces put on the weighing pan.

Example procedure

- 1 Press to enter the applications menu.
➔ CHOOSE APPLICATION is displayed.
- 2 Press \uparrow or \downarrow to select the application COUNTING.
- 3 Press \checkmark to confirm your selection.
➔ The icon PIECE COUNTING is displayed and the corresponding weighing application opens.

Methods for setting reference weight

"Piece counting" first requires the setting of a reference weight, there are 2 possibilities:

- **A** Setting the reference average weight **by weighing**.
- **B** Setting the reference average weight **by entering manually**.

A Weighing reference values

- 1 Access APP.SET using and by pressing \checkmark .
- 2 Select the entry AVG.WGT using \uparrow or \downarrow .
- 3 Press \checkmark to confirm your selection.
- 4 Select the entry MEASURE using \uparrow or \downarrow .
- 5 Press \checkmark to confirm your selection.
- 6 Adapt the number of reference pieces using \uparrow or \downarrow .
Adapt digit by digit and confirm each digit by pressing \checkmark^* .
- 7 Press \checkmark to confirm your selection.
- 8 Press $\rightarrow 0 \leftarrow$ to zero the balance. If using: place empty container on the weighing pan and press $\rightarrow T \leftarrow$ to tare the balance.
- 9 Add the selected number of reference pieces to container.

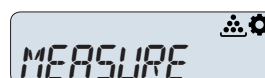
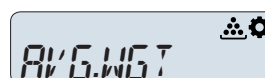
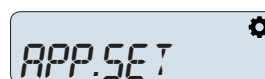

10

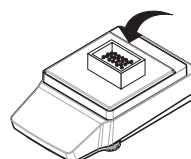
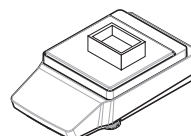

- ➔ The overall weight of the reference pieces is displayed.

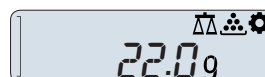

- 10 Press \checkmark to confirm your selection.
➔ The reference weight next to the top entry REF= displays the calculated value of a single piece.

- 11 Return APP.SET by pressing \times .

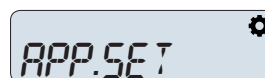



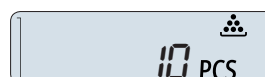











- 12 Press \times again to enter the weighing screen.



- ➔ The balance is ready for counting pieces with the determined reference weight.



* with approved balances in selected countries: min 10.

B Entering reference value manually

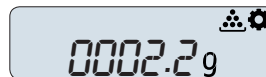
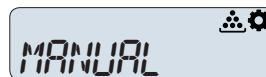
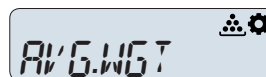
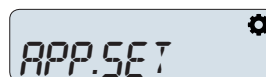
- 1 Access APP.SET using  and by pressing .
- 2 Select the entry AVG.WGT using  or .
- 3 Press  to confirm your selection.
- 4 Select the entry MANUAL using  or .
- 5 Confirm your selection by pressing .
- 6 Enter the reference weight of one piece using  or . Adapt digit by digit and confirm each digit by pressing *.
- 7 Press  to confirm your selection.
➔ The reference weight next to the top entry REF= displays the entered value of a single piece.
- 8 Return APP.SET by pressing .
- 9 Press  again to enter the weighing screen.
➔ The balance is ready for counting pieces with the determined reference weight.



Using piece counting application



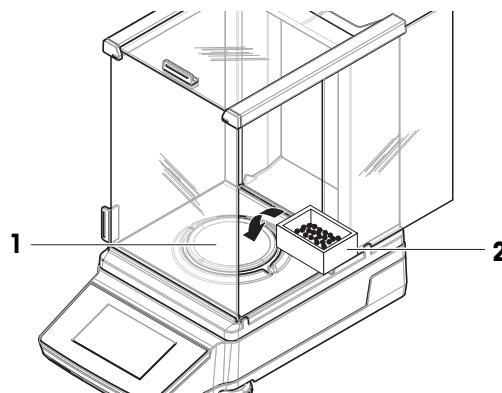

- 1 Zero the balance by pressing . If using: place empty container on the weighing pan and tare the balance by pressing .
- 2 Open the draft shield door (if applicable).
- 3 Place the tare container (2) on the weighing pan (1).
- 4 Tare the balance.
- 5 Place the pieces to be counted in the container.
- 6 Close the draft shield door (if applicable).
- 7 Wait until the weight stabilizes.
➔ The number of pieces is displayed.
- 8 Optional, depending on the settings: Press  PUBLISH to print or export the weighing result.







5.1.4 Application "Percent weighing"

The application "Percent weighing" allows a sample weight to be checked as a percentage of a reference target weight. You can set your reference weight by measuring or by manually entering a value.

Example procedure

- 1 Press  to enter the application menu.
➔ The Coach Text CHOOSE APPLICATION is displayed.
- 2 Press  or  to select the application PERCENT.
- 3 Press  to confirm your selection.
➔ The icon % "Percent weighing" is displayed and the corresponding weighing applications opens.

Setting a reference weight by measuring

- 1 Press  to enter the settings menu.
- 2 Press  or  to select APP.SET.
- 3 Press  to confirm your selection.

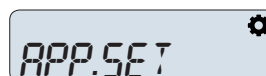

- ➔ The Coach Text REF.WGT is displayed. You can now choose to measure or to enter the reference weight.
- 4 Press ✓ to start selecting a method to determine the reference weight.
- 5 Select MEASURE to determine the reference weight by measuring an object.
- 6 Press ✓ to confirm your selection.
 - ➔ The Coach Text PLACE REF. SAMPLE prompts you to place a reference weight on the weighing pan.
- 7 Press →0← to zero the balance. If using: place empty container on the weighing pan and press →T← to tare the balance.

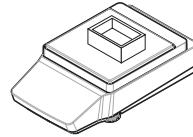

- 8 Place the reference object on the weighing pan.
- 9 Weight until the weighing result is stable.
- 10 Press ✓ to confirm the measured reference weight..
 - ➔ The Coach Text 100%= X G (X = <your reference weight>) is displayed. Setting the reference weight by measuring is complete.

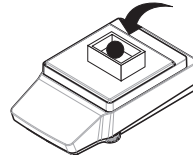

● = 100%

Entering a reference weight manually

- 1 Press ⚙ to enter the settings menu.
- 2 Press ↑ or ↓ to select APP.SET.
- 3 Press ✓ to confirm your selection.
 - ➔ The Coach Text REF.WGT is displayed. You can now choose to measure or to enter the reference weight.
- 4 Press ✓ to start selecting a method to determine the reference weight.

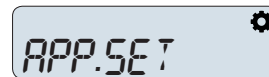

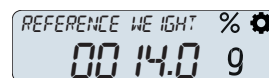

- 5 Select MANUAL to enter the reference weight manually.
- 6 Press ✓ to confirm your selection.
 - ➔ The Coach Text REFERENCE WEI HGT is displayed. You can now enter the reference weight.
- 7 Adapt the reference weight digit by digit using ↑ or ↓. Confirm your choice for each digit with ✓
- 8 Press ✓ to confirm the entered reference weight..
 - ➔ The Coach Text 100%= X G (X = <your reference weight>) is displayed. Entering the reference weight manually is complete.

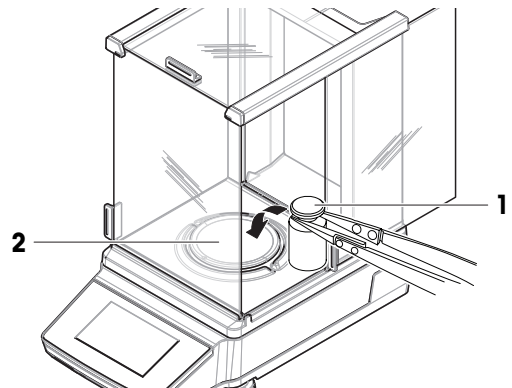

Performing a percent weighing

- 1 Press →0← to zero the balance.
- 2 Open the draft shield door (if applicable).
- 3 Place the weighing object (1) on the weighing pan (2).
- 4 Close the draft shield door (if applicable).
- 5 Wait until the weight stabilizes.



- ➔ The coach text indicates the reference weight. The weighing result is displayed.
- 6 Press **↑** or **↓** to display your weighing result as a percentage of the reference weight..
 - ➔ The percent value is displayed.
 - 7 Optional, depending on the settings: Press  PUBLISH to print or export the weighing result.

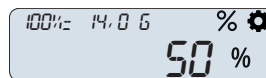
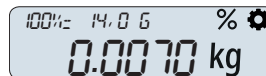



5.1.5 Application "Formulation"

The application "Formulation" allows you to.

- weigh in (add and store) up to 999 individual component weights and display the total. If a printer is connected, the component weights are printed individually and as a total.
- tare and store up to 999 container weights and display the total. If a printer is connected, the tare weights are printed individually and as a total.
- fill up the sum of all component net weight values by adding a further component to a higher value.

Performing a formulation

- 1 Tap  to enter the application menu.
 - ➔ The coach text CHOOSE APPLICATION is displayed.
- 2 Tap **↑** or **↓** to select the application FORMULA.
- 3 Tap **✓** to confirm your selection.
 - ➔ The icon  "Formulation" is displayed and the corresponding weighing applications opens.
- 4 If necessary zero the balance by pressing **→←**.
- 5 Place your first sample on the weighing pan.
 - ➔ The sample weight is displayed along with the coach text PRESS UP KEY TO ADD.
- 6 Press **↑** to proceed with the second sample.
 - ➔ The first sample weight is added. After saving the coach text PLACE SAMPLE 2 is displayed.
- 7 Leave the first sample on the weighing pan. Add the second sample onto the weighing pan.
 - ➔ The weight of the second sample is displayed. The corresponding sample number is incremented by one.
- 8 Press **↑** to proceed with the next sample.
 - ➔ The weight is saved and the coach text indicates the next step.
- 9 Repeat placing samples and pressing **↑** for all remaining samples.
- 10 Press **✓** to finish the sample weighing.
- 11 Choose between COMPLETE, PAUSE and RESULT using **↑** or **↓** and confirming with **✓**.
 - ➔ If COMPLETE is selected, the cumulative weight is displayed and transferred to the printer (if connected).
 - ➔ If PAUSE is selected, you can resume the weighing process by pressing **✓**.
 - ➔ If RESULT is selected, NUMBER OF SAMPLES is displayed. You may change to TOTAL GROSS WEIGHT by pressing **↑** or **↓**.

Note

Additionally, you have the option to fill up the sample to your target amount by pressing **↓** after the last sample is added. The net total will then be displayed, allowing you to fill up to your desired value.

Discarding samples

- 1 Press **✕** to open the menu DISCARD SAMPLES.
- 2 Select LAST using **↑** or **↓** and confirm your selection with **✓** to discard the last sample weighed.
 - ➔ The display text indicates that the sample with a number corresponding to the last sample used has been discarded.
- 3 Select ALL and confirm your selection with **✓** to discard all samples weighed.

- ➔ The coach text prompts you to place the first sample. All samples have been discarded.





5.1.6 Application "Dynamic Weighing"

The "Dynamic weighing" application allows you to determine the weights of unstable samples or to determine weights under unstable ambient conditions. The balance calculates the weight as the average of a number of weighing operations over a defined time.









Using sample identification

Weighing operations can be linked to a sample identification. You can activate and set up the sample ID in the APP.SET menu ([Using a sample ID ▶ Page 44]).

Example procedure







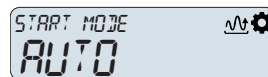
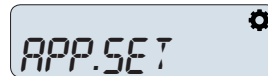

- 1 Press  to enter the applications menu.
- 2 Press  to confirm your selection.
 - ➔ The icon  DYNAMIC WEIGHING is displayed and the corresponding weighing application opens.
 - ➔ CHOOSE APPLICATION is displayed.
- 3 Press  or  to select the application DYNAMIC.

Setting start mode

- 1 Access APP.SET using  and by pressing .
- 2 Select the entry in the menu item START MODE using  or .
- 3 Press  to confirm your selection.
- 4 Adapt the START MODE to AUTO or MANUAL using  or .
- 5 Confirm your selection by pressing .
 - ➔ In AUTO start mode placing an item on the weighing pan triggers the weighing process. In MANUAL start mode pressing  when the weighing screen is displayed triggers the weighing process.







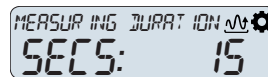
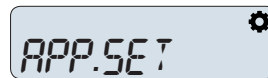



Setting measuring duration

- 1 Access APP.SET using  and by pressing .
- 2 Select menu item with the coach text MEASURING DURATION using  or .
- 3 Press  to confirm your selection.
- 4 Adapt the measuring duration in s digit by digit using  or .
- 5 Press  to confirm your selection.
 - ➔ The balance is set to manual start mode. Dynamic weighing is being started, by pressing  when the weighing screen is displayed.



Setting sample taring

- 1 Access APP.SET using  and by pressing .
- 2 Select menu item with the coach text SAMPLE TARE using  or .
- 3 Press  to confirm your selection.
- 4 Adapt the sample tare setting by changing from ON to OFF or vice versa pieces using  or .
- 5 Press  to confirm your selection.
 - ➔ The sample tare has been set. If set to ON, the balance will perform taring after the dynamic weighing procedure has been completed. If set to OFF, no taring is performed.

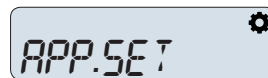

Performing a dynamic weighing

- 1 Return to the weighing screen using **X**.
- 2 If using MANUAL start mode: Place your item on the weighing pan and press **✓** to start the weighing process.
- 3 If using AUTO start mode: Place your item on the weighing pan to start the weighing process automatically.
 - ➔ Dynamic weighing is performed for the set measuring duration and on completion, the result is displayed. If sample taring is activated, the balance performs a taring after the item has been removed.

See also

 Using a sample ID ▶ Page 44



5.1.7 Application "Density"

The "Density" application allows you to determine the density of solid bodies. Determination of the density uses **Archimedes' principle** according to which a body immersed in a fluid undergoes an apparent loss in weight which is equal to the weight of the fluid it displaces.

To determine the density of solid bodies, we recommend you to work with the optional density kit which contains all the attachments and aids needed for convenient and precise density determination.

Note



You can also use the weighing hook for weighing below the balance which belongs to your balance.

- 1 Press  to enter the applications menu.
 - ➔ CHOOSE APPLICATION is displayed.
- 2 Press **↑** or **↓** to select the application "DENSITY".
- 3 Press **✓** to confirm your selection.
 - ➔ The icon  is displayed and the corresponding weighing application "DENSITY" opens.

5.1.7.1 Determining the density of solids

Determining the density of solids requires selecting an auxiliary liquid. Depending on the selected liquid specific properties have to be entered. Water and auxiliary liquid must have a temperature between 10°C and 30.9°C.

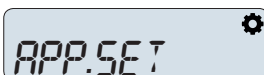
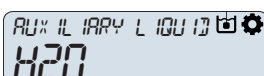
If using water

- 1 Press  to access APP.SET and confirm by pressing **✓**.
- 2 Start selecting the auxiliary liquid by pressing **✓**.
- 3 Select H2O by pressing **↑** or **↓**. Press **✓** to confirm your selection.
- 4 Access the TEMPERATURE setting by pressing **↑** or **↓**.
- 5 Enter the temperature setting by pressing **✓**.
- 6 Measure the temperature of the water.
- 7 Adapt the set temperature digit by digit using **↑** or **↓**. Confirm your choice for each digit with **✓**.
 - ➔ After confirming the last digit, the temperature is set.
- 8 Enter the measuring screen by pressing **X** twice.
 - ➔ For water the density will be calculated automatically. The balance is ready for measuring density.

If using a freely definable auxiliary liquid

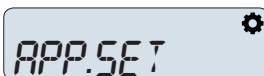
- 1 Press  to access APP.SET and confirm by pressing **✓**.
- 2 Start selecting the auxiliary liquid by pressing **✓**.

- 3 Select a CUSTOM liquid using ↑ or ↓ and confirm by pressing ✓.

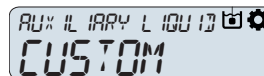

- 4 Access the density setting using ↑ or ↓.
 5 Press ✓ to enter the AUX LIQUID DENSITY setting.
 6 Adapt the set density digit by digit using ↑ or ↓. Confirm your choice for each digit with ✓.

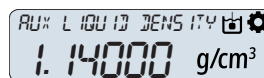

- ➔ After confirming the last digit, the density is set.
 7 Enter the TEMPERATURE setting using ↑ or ↓. Confirm your choice with ✓.
 8 Measure the temperature of the auxiliary liquid.
 9 Adapt the set temperature digit by digit using ↑ or ↓. Confirm your choice for each digit with ✓.



- ➔ After confirming the last digit, the temperature is set.
 10 After entering the temperature press ✕ twice to enter the measuring screen.
 ➔ The balance is ready for measuring density.

Performing a density determination

- PLACE KIT AND START is displayed.
- 1 Place your density kit as described in the according manual.
- 2 Press ✓ to start.
 - ➔ The balance performs taring/zeroing. After this, WEIGH IN AIR is displayed.
- 3 Load the solid.
- 4 Press ✓ to start measuring.
 - ➔ After weighing in air is complete, WEIGH IN LIQUID is displayed.
- 5 Load the solid.
 - ➔ After weighing in liquid is complete, RESULT is displayed in g/cm³.

5.1.7.2 Formulas used to calculate density

The application "Density" is based on the formulae listed below.

Formulae for determining the density of solids with compensation for air density

$$\rho = \frac{A}{A-B} (\rho_0 - \rho_L) + \rho_L$$

$$V = \alpha \frac{A - B}{\rho_0 - \rho_L}$$

- ρ = Density of the sample
- A = Weight of the sample in air
- B = Weight of the sample in the auxiliary liquid
- V = Volume of the sample
- ρ₀ = Density of the auxiliary liquid
- ρ_L = Density of air (0.0012 g/cm³)
- α = Weight correction factor (0.99985), to take the atmospheric buoyancy of the adjustment weight into account

Density of distilled water

T/ °C	0	0.1	0.2	0.3	0.4	0.5	0.6	0.7	0.8	0.9
10	0.99970	0.99969	0.99968	0.99967	0.99966	0.99965	0.99964	0.99963	0.99962	0.99961
11	0.99960	0.99959	0.99958	0.99957	0.99956	0.99955	0.99954	0.99953	0.99952	0.99951
12	0.99950	0.99949	0.99947	0.99946	0.99945	0.99944	0.99943	0.99941	0.99940	0.99939
13	0.99938	0.99936	0.99935	0.99934	0.99933	0.99931	0.99930	0.99929	0.99927	0.99926

T/ °C	0	0.1	0.2	0.3	0.4	0.5	0.6	0.7	0.8	0.9
14	0.99924	0.99923	0.99922	0.99920	0.99919	0.99917	0.99916	0.99914	0.99913	0.99911
15	0.99910	0.99908	0.99907	0.99905	0.99904	0.99902	0.99901	0.99899	0.99897	0.99896
16	0.99894	0.99893	0.99891	0.99889	0.99888	0.99886	0.99884	0.99883	0.99881	0.99879
17	0.99877	0.99876	0.99874	0.99872	0.99870	0.99869	0.99867	0.99865	0.99863	0.99861
18	0.99859	0.99858	0.99856	0.99854	0.99852	0.99850	0.99848	0.99846	0.99844	0.99842
19	0.99840	0.99838	0.99836	0.99835	0.99833	0.99831	0.99828	0.99826	0.99824	0.99822
20	0.99820	0.99818	0.99816	0.99814	0.99812	0.99810	0.99808	0.99806	0.99803	0.99801
21	0.99799	0.99797	0.99795	0.99793	0.99790	0.99788	0.99786	0.99784	0.99781	0.99779
22	0.99777	0.99775	0.99772	0.99770	0.99768	0.99765	0.99763	0.99761	0.99758	0.99756
23	0.99754	0.99751	0.99749	0.99747	0.99744	0.99742	0.99739	0.99737	0.99734	0.99732
24	0.99730	0.99727	0.99725	0.99722	0.99720	0.99717	0.99715	0.99712	0.99709	0.99707
25	0.99704	0.99702	0.99699	0.99697	0.99694	0.99691	0.99689	0.99686	0.99684	0.99681
26	0.99678	0.99676	0.99673	0.99670	0.99667	0.99665	0.99662	0.99659	0.99657	0.99654
27	0.99651	0.99648	0.99646	0.99643	0.99640	0.99637	0.99634	0.99632	0.99629	0.99626
28	0.99623	0.99620	0.99617	0.99615	0.99612	0.99609	0.99606	0.99603	0.99600	0.99597
29	0.99594	0.99591	0.99588	0.99585	0.99582	0.99579	0.99577	0.99574	0.99571	0.99568
30	0.99564	0.99561	0.99558	0.99555	0.99552	0.99549	0.99546	0.99543	0.99540	0.99537

ISO 15212-1:1998 Oscillation-type density meters – Part 1: Laboratory instruments

5.1.8 Application "Check weighing"

The application "Check weighing" allows you to check the deviation of a sample weight within a tolerance limit to a reference target weight.

Using sample identification

Weighing operations can be linked to a sample Identification. You can activate and set up the sample ID in the APP.SET menu ([Using a sample ID ▶ Page 44]).

Methods of setting the reference

- Setting the reference **in weighing mode** (weigh nominal weight).
- Setting the reference **in manual mode** (enter nominal weight).

Setting reference in weighing mode

1 Access APP.SET using  and by pressing .

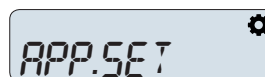

2 Select the entry TARGET.W using  or .

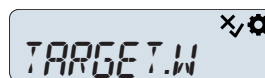

3 Press  to confirm your selection.

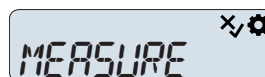

4 Select the entry MEASURE using  or .

5 Press  to confirm your selection.



6 Press  to zero the balance. If using: place empty container on the weighing pan and press  to tare the balance.

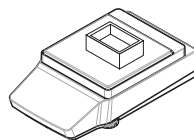

7 Place the nominal weight on the weighing pan.

8 Start weighing the nominal weight by pressing .

➔ The value of the nominal weight replaces the target value. You may now adapt the tolerances.

9 Select the entry + / - TOLERANCES using  or .

10 Press  to confirm your selection.

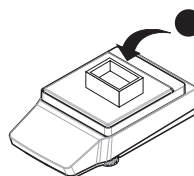

- 11 Enter the value for positive and negative tolerance in "%" using \uparrow or \downarrow . Adapt digit by digit and confirm each digit by pressing \checkmark .
- ➔ The tolerances are displayed. You may now adapt the Tolerances unit.

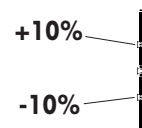

- 12 Select the entry UNIT: using \uparrow or \downarrow .
- 13 Press \checkmark to confirm your selection.
- ➔ The selected unit is displayed blinking.
- 14 Select an absolute tolerance in "g" or a relative tolerance in "%" using \uparrow or \downarrow .
- 15 Press \checkmark to confirm your selection.
- ➔ Nominal value, tolerance and unit have been set. You may now start check weighing.

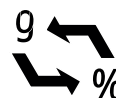
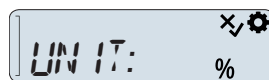

Setting the reference in manual mode

- 1 Access APP.SET using \odot and by pressing \checkmark .
- 2 Select the entry TARGET.W using \uparrow or \downarrow .
- 3 Press \checkmark to confirm your selection.
- 4 Select the entry MANUAL using \uparrow or \downarrow .
- 5 Press \checkmark to confirm your selection.
- 6 Enter the TARGET WEIGHT using \uparrow or \downarrow . Adapt digit by digit and confirm each digit by pressing \checkmark .
- ➔ The target weight is displayed. You may now adapt the tolerances.
- 7 Select the entry + / - TOLERANCES using \uparrow or \downarrow .
- 8 Press \checkmark to confirm your selection.
- 9 Enter the value for positive and negative tolerance in "%" using \uparrow or \downarrow . Adapt digit by digit and confirm each digit by pressing \checkmark .
- ➔ The tolerances are displayed. You may now adapt the Tolerances unit.

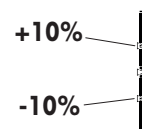
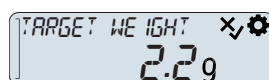
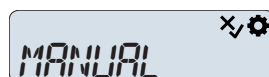
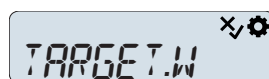
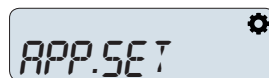

- 10 Select the entry UNIT: using \uparrow or \downarrow .
- 11 Press \checkmark to confirm your selection.
- ➔ The selected unit is displayed blinking.
- 12 Switch between "g" and "%" using \uparrow or \downarrow .
- 13 Press \checkmark to confirm your selection.
- ➔ Nominal value, tolerance and unit have been set. You may now start check weighing.

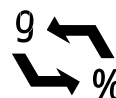
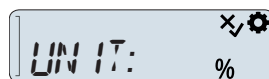

Performing a check weighing

- 1 Press $\rightarrow\text{O}\leftarrow$ to zero the balance. If using: place empty container on the weighing pan and press $\rightarrow\text{t}\leftarrow$ to tare the balance.

- Place the item to be check-weighed on the weighing pan.

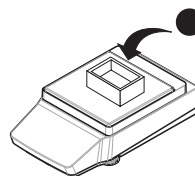

- ➔ The weight is displayed. If the placed weight is within the set tolerance, the tolerance bar indicates the position within the tolerance window. If the weight of the placed item exceeds the set tolerance, ABOVE TOLERANCE is displayed. Accordingly BELOW TOLERANCE is displayed, if the placed weight is below the tolerance.

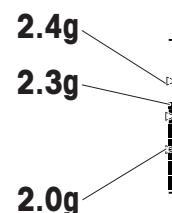

5.1.9 Application "Factor weighing"

The application "Factor weighing" allows you to automatically perform a mathematical operation on the measured weight. The weighing result is a calculated value depending on the selected operation:

- Result = Weight * Factor (Multiplication factor)
- Result = Factor / Weight (Division factor)
- Result = Weight + Factor (Addition factor)
- Result = Weight - Factor (Subtraction factor)

Example procedure

- Press to enter the application menu.
 - ➔ The Coach Text CHOOSE APPLICATION is displayed.
- Press or to select the application FACTOR.
- Press to confirm your selection.
 - ➔ The icon "Factor weighing" is displayed and the corresponding weighing applications opens.

Choosing a mathematical operation

- Press to enter the settings menu.
- Press or to select APP.SET.
- Press to confirm your selection.
 - ➔ The Coach Text METHOD UPON GRAM is displayed.

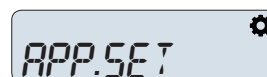

You can now choose the mathematical operation performed on the weighing result.

- Press to start selecting an operation.
- Press or to select from (MULTIPLY | DIVIDE | PLUS | MINUS).
- Press to confirm your selection.
 - ➔ The mathematical operation is set. You can now define the factor value to be applied.
- Press twice to select the FACTOR VALUE setting.
- Press to confirm your selection.
- Enter the factor value to be applied. Depending on the selected mathematical operation this value factor is now multiplier, divisor, summand or subtrahend.

- * X MULT IPLY
- / X D I V I D E
- + X PLUS
- X M I N U S



Performing a factor weighing

- Press to zero the balance.
- Open the draft shield door (if applicable).

- 3 Place the weighing object on the weighing pan.
- 4 Close the draft shield door (if applicable).
- 5 Wait until the weight stabilizes.

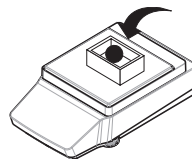

● = 14g

- ➔ The coach text indicates the mathematical operation performed and the factor value applied. The result is displayed taking into account the mathematical operation selected.

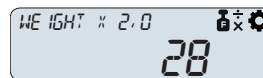

14g x 2.0 = 28

- 6 Optional, depending on the settings: Press PUBLISH to print or export the weighing result.

5.1.10 Application "Statistics"

The application "Statistics" allows you to generate statistics of a series of weighing values. 1 to 999 values are possible.

- 1 Press to enter the applications menu.
 - ➔ The coach text CHOOSE APPLICATION is displayed.
- 2 Press or to select the entry STAT.
- 3 Press to confirm your selection.
 - ➔ The icon "Statistics" is displayed and the corresponding weighing applications opens.

- 1 Place the first sample on the weighing pan.
- 2 Press to add the first sample to the calculation.
 - ➔ The balance confirms that the first sample has been added. The coach text REMOVE SAMPLE is displayed.

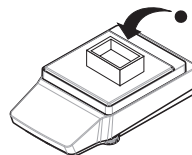

- 3 Remove the first sample from the weighing pan.
 - ➔ The coach text prompts to place the second sample.

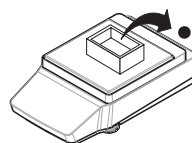

- 4 Place the second sample on the weighing pan.

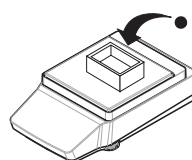

- 5 Press to add the second sample to the calculation.
 - ➔ The balance confirms that the second sample has been added and prompts to remove this sample.

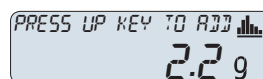

- 6 Repeat placing, confirming and removing samples until all samples have been weighed and added to the calculation.

- 7 Tap to finish the sample weighing.
- 8 Choose between COMPLETE, PAUSE and RESULT using or and confirming with .

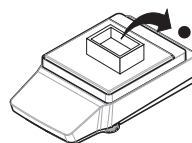

- ➔ If COMPLETE is selected, the calculated results are displayed and transferred to the printer (if connected).
- ➔ If PAUSE is selected, you can resume the weighing process by pressing .
- ➔ If RESULT is selected, COUNT is displayed. You may change to the AVERAGE X, SUM, MINIMUM MAXIMUM, RANGE, STANDARD DEVIATION or REL.STD.DEVIATION by pressing or .

Discarding samples

- 1 Press to open the menu DISCARD SAMPLES.

- 2 Select LAST using \uparrow or \downarrow and confirm your selection with \checkmark to discard the last sample weighed.
 - ➔ The display text indicates that the sample with a number corresponding to the last sample used has been discarded.
- 3 Select ALL and confirm your selection with \checkmark to discard all samples weighed.
 - ➔ The coach text prompts you to place the first sample. All samples have been discarded.

5.1.11 Application "Totaling"

The application "Totaling" allows you to weigh in different samples to add their weight values and to totalize them. 1 to 999 samples are possible.

- 1 Press \square to enter the application menu.
 - ➔ The Coach Text CHOOSE APPLICATION is displayed.
- 2 Press \uparrow or \downarrow to select the application TOTALING.
- 3 Press \checkmark to confirm your selection.
 - ➔ The icon Σ "Totaling" is displayed and the corresponding weighing applications opens.

Performing a totaling

- 1 Place your first sample on the weighing pan.
 - ➔ The sample weight is displayed along with the coach text PRESS UP KEY TO ADD.
- 2 Tap \uparrow proceed with the second sample.
 - ➔ The first sample weight is added. After saving the coach text PLACE SAMPLE 2 is displayed.
- 3 Leave the first sample on the weighing pan and add the second sample onto the weighing pan.
 - ➔ The weight of the second sample is displayed.
- 4 Tap \uparrow proceed with the next sample.
 - ➔ The weight is added and the coach text indicates the next step.
- 5 Repeat the last step, until all samples have been weighed.
- 6 Tap \checkmark to finish the sample weighing.
- 7 Choose between COMPLETE, PAUSE and RESULT using \uparrow or \downarrow and confirming with \checkmark .
 - ➔ If COMPLETE is selected, the cumulative weight is displayed and transferred to the printer (if connected).
 - ➔ If PAUSE is selected, you can resume the weighing process by pressing \checkmark .
 - ➔ If RESULT is selected, COUNT is displayed. You may change to the GROSS TOTAL by pressing \uparrow or \downarrow .

Discarding samples

- 1 Press \times to open the menu DISCARD SAMPLES.
- 2 Select LAST using \uparrow or \downarrow and confirm your selection with \checkmark to discard the last sample weighed.
 - ➔ The display text indicates that the sample with a number corresponding to the last sample used has been discarded.
- 3 Select ALL and confirm your selection with \checkmark to discard all samples weighed.
 - ➔ The coach text prompts you to place the first sample. All samples have been discarded.

5.2 Using a sample ID

When the sample ID is activated, weighing results are assigned to this ID when printing the results. The sample ID is available for most applications.

- 1 Access APP.SET using ⚙ and by pressing \checkmark .
- 2 Select the entry in the menu item SAMPLE ID using \uparrow or \downarrow .
- 3 Press \checkmark to confirm your selection.
- 4 Change SAMPLE ID to ON using \uparrow or \downarrow .
- 5 Confirm your selection by pressing \checkmark .

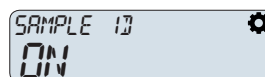
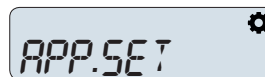

- ➔ The sample ID is activated. You can now edit the SAMPLE ID NAME manually or activate an automatic increment.

Editing a sample ID manually

- 1 Adapt the sample ID digit by digit using ↑ or ↓. Press ✓ to confirm each digit.
- 2 After editing the last digit, press ✓ to confirm the entered sample ID.
 - ➔ The next weighing will be assigned to the sample ID just entered.



Activating auto increment

- 1 Select the entry in the menu item AUTO INCREMENT using ↑ or ↓.
- 2 Press ✓ to confirm your selection.
- 3 Change AUTO INCREMENT to ON using ↑ or ↓.
 - ➔ The sample ID will now be incremented by 1 for each weighing process.



5.3 Adjustments

Types of adjustments

The internal adjustment is performed with a build in weight. For the external adjustment a test weight is required.

Performing an internal adjustment

- 1 Press  to enter the settings menu.
 - ➔ The coach text ADJUSTMENT TYPE is displayed.
- 2 Press ↑ or ↓ to select the menu entry ADJ.INT.
- 3 Press ✓ to confirm your selection.
 - ➔ The internal adjustment is started. The coach text ADJUSTMENT ONGOING is displayed. A successful adjustment is indicated by PASSED. If the adjustment was not successful try starting the internal adjustment again. If your instrument fails the adjustment, inform a METTLER TOLEDO service technician.

Performing an external adjustment

- 1 Press  to enter the settings menu.
 - ➔ The coach text ADJUSTMENT TYPE is displayed.
- 2 Press ↑ or ↓ to select the menu entry ADJ.EXT.
- 3 Press ✓ to confirm your selection.
- 4 Enter the weight of the adjustment weight using ↑ or ↓ digit by digit. Confirm each digit by pressing ✓.
- 5 Place a test weight with the entered weight on the weighing pan.
 - ➔ The external adjustment is started. The coach text ADJUSTMENT ONGOING is displayed. A successful adjustment is indicated by PASSED. If the adjustment was not successful, repeat the external adjustment. If your instrument fails the adjustment, inform a METTLER TOLEDO service technician.

5.4 Devices / Printers

5.4.1 Printer

Printers serve to document your processes and results. Each weighing application offers the possibility to trigger the printing process manually. The balance can also be configured such that the results are automatically printed.



NOTICE

Damage to the device due to inappropriate use

- Consult the User Manual of the device before using it.

Note













A suitable cable from METTLER TOLEDO must be used to ensure proper function.

5.4.1.1 Installing a printer through USB

A USB printer is automatically detected by the balance (plug and play).

- The printer is switched on.
- A suitable cable to connect the printer to the balance is available.
- On the balance, the main weighing screen is open.
 - 1 Connect the cable to the printer.
 - 2 Connect the cable to the USB port of the balance.
 - ➔ The icon  appears on the main weighing screen.
 - 3 Configure the printer.
- ➔ The printer is ready for use.

5.4.1.2 Installing a printer through RS232

- The printer is switched on.
- A suitable cable to connect the printer to the balance is available.
- On the balance, the main weighing screen is open.
 - 1 Connect the cable to the printer.
 - 2 Connect the cable to the RS232 port of the balance.
 - 3 Press  to enter the settings menu.
 - 4 Press  or  to select BAL.SET.
 - 5 Press  to confirm your selection.
 - 6 Press  or  to select INT.FACE.
 - 7 Press  to confirm your selection.
 - 8 Press  or  to select RS232.
 - 9 Press  to confirm your selection.
 - 10 Press  or  to set the connection to P-20 or P-50, depending on the printer series.
 - 11 Press  to confirm your selection.
 - 12 Configure the printer.
- ➔ The printer is ready for use.

5.4.2 Foot switch

















The foot switch can be used to perform taring, zeroing or printing without having to use the terminal.

Installing the foot switch

















A foot switch is automatically detected by the balance (plug and play).

- On the balance, the main weighing screen is open.
 - Connect the foot switch to the USB port of the balance.
 - ➔ The icon  appears on the main weighing screen.
- ➔ The foot switch is ready for use and can be used for taring.

Changing the function of the foot switch

- A foot switch is connected to the balance.
- On the balance, the main weighing screen is open.
- 1 Press  to enter the settings menu.
- 2 Press  or  to select BAL.SET.
- 3 Press  to confirm your selection.
- 4 Press  or  to select INT.FACE.
- 5 Press  to confirm your selection.
- 6 Press  or  to select USB.
- 7 Press  to confirm your selection.
- 8 Press  or  to select TARE.
- 9 Press  to confirm your selection.
- 10 Press  or  to change the function the foot switch to PUBLISH or ZERO.
- 11 Press  to confirm your selection.
- ➔ The operation to be performed by the foot switch has been changed.













Turning off the foot switch

- A foot switch is connected to the balance.
- On the balance, the main weighing screen is open.
- 1 Press  to enter the settings menu.
- 2 Press  or  to select BAL.SET.
- 3 Press  to confirm your selection.
- 4 Press  or  to select INT.FACE.
- 5 Press  to confirm your selection.
- 6 Press  or  to select USB.
- 7 Press  to confirm your selection.
- 8 Press  or  to select ON.
- 9 Press  to confirm your selection.
- 10 Press  or  to change the setting to OFF.
- 11 Press  to confirm your selection.
- ➔ The foot switch is turned off.

5.4.3 Auxiliary display

The auxiliary display duplicates the information of the balance display.

Installing the auxiliary display

- On the balance, the main weighing screen is open.
- 1 Connect the auxiliary display to the RS232 port of the balance.
- 2 Press  to enter the settings menu.
- 3 Press  or  to select BAL.SET.
- 4 Press  to confirm your selection.
- 5 Press  or  to select INT.FACE.
- 6 Press  to confirm your selection.
- 7 Press  or  to select RS232.
- 8 Press  to confirm your selection.
- 9 Press  or  to set the connection to 2.DISPLAY.

10 Press ✓ to confirm your selection.

➔ The auxiliary display switches on. It switches automatically off and on with the balance.

Note

To switch off the auxiliary display permanently, disconnect it from the balance.

5.4.4 Exporting data to a USB storage device

This function allows you to export the weighing data to a USB storage device in the file formats TXT and CSV, which can be used to transfer the data to a computer.

Exporting weighing data

1 Insert the USB storage device.

2 Make sure the connectivity icon ↔ is visible in the screen.

3 Press ⚙ to enter the settings menu.

4 Press ↑ or ↓ to select BAL.SET.

5 Press ✓ to confirm your selection.

6 Press ↑ or ↓ to select PUBLISH.

7 Press ✓ to confirm your selection.

8 Press ↑ or ↓ to select EXPORT FILE.

9 Press ✓ to confirm your selection.

10 Press ↑ or ↓ to select ON.

11 Press ✓ to confirm your selection.

12 Press 🏠 to go back to the main weighing screen.

13 Weigh a few samples and press 📄 to transfer the result to the USB storage device.

➔ The symbol 🔄 appears to indicate that data transfer is in progress.

NOTICE: Do not remove the USB storage device as long as the symbol is displayed.

14 Remove the USB storage device and view the data on your computer.

Exporting configuration data

1 Insert the USB storage device.

2 Make sure the connectivity icon ↔ is visible in the screen.

3 Press ⚙ to enter the settings menu.

4 Press ↑ or ↓ to select BAL.SET.

5 Press ✓ to confirm your selection.

6 Press ↑ or ↓ to select MAINT.

7 Press ✓ to confirm your selection.

8 Press ↑ or ↓ to select EXPORT.

9 Press ✓ to confirm your selection.

➔ START is preselected.

10 Press ✓ to confirm your selection.

11 Press ↑ or ↓ to select one of the following options:

– BAL+APP to export the balance and application settings

– BAL to export the balance settings

– APP to export the application settings

12 Press ✓ to confirm your selection.

13 Wait until the export is complete.

14 Press 🏠 to go back to the main weighing screen.

15 Remove the USB storage device.

16 Insert the USB storage device on your computer

17 Check if the file (.jne) was successfully transferred.

➔ The balance and/or application settings can now be imported to another MA balance model, provided that model and software version of both balances are identical.

5.5 Services

5.5.1 PC-Direct function

The PC-Direct function of the balance allows you to transfer weighing results from the balance to a Windows application. The weight value and weight unit displayed on the balance are transferred to the cursor position in, e.g., Excel or Word.

Requirements

- Computer with one of the following Microsoft Windows® 32-bit/64-bit operating systems: Win 7 (SP1), Win 8, Win 10, or Win 11
- Serial interface RS232 or USB
- Administrator rights for installing the SerialPortToKeyboard software (if data transfer is via RS232)
- Windows application (e.g., Excel)
- Connection between balance and computer via a suitable cable from METTLER TOLEDO

Installing SerialPortToKeyboard software

The operation of PC-Direct via serial port RS232C requires the installation of **SerialPortToKeyboard** on your host computer. The file **SerialPortToKeyboard** can be found on ► www.mt.com/labweighing-software-download. If you have any questions, please contact a METTLER TOLEDO representative.

Download SerialPortToKeyboard

- 1 Connect to the internet.
- 2 Go to the site www.mt.com/labweighing-software-download.
- 3 Click **Download Software and Instructions** in section **SerialPortToKeyboard software for Advanced and Standard level laboratory balances**.
 - ➔ A pop-up window with interactions appears.
- 4 Click, e.g., **Open**.
 - ➔ The extract screen appears.
- 5 Extract the file **SerialPortToKeyboard_V_x.xx_installer_and_instructions.zip** to your specified location.
- 6 Right-click on the downloaded installation program **SerialPortToKeyboard_V_x.xx.exe** and select **Run as Administrator**.
- 7 If a safety warning appears, confirm windows to perform the installation.
- 8 Click **Next** and follow the installer's instructions.

Checking operation

- 1 Start **SerialPortToKeyboard** (RS232)
- 2 Start Excel (or another application) on the computer.
- 3 Activate a cell in Excel.



Settings on the PC

Settings for SerialPortToKeyboard

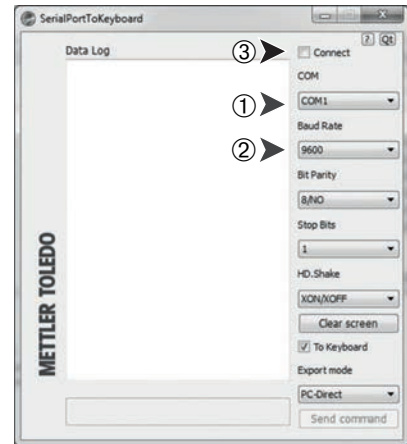
- 1 Select the serial port **COM** for the connection with the balance.
- 2 Set the **Baud Rate** to **9600**.
- 3 Activate **Connect**.
 - Closing the window terminates the session.







Settings at the balance

- 1 Access the settings menu by pressing .
- 2 Select BAL.SET and confirm with .
- 3 Scroll down and select INT.FACE.
- 4 Select RS232 as connectivity.
- 5 Select RS232 CONNECTION.
- 6 Set the connection to PC.DIRECT.
- 7 Select the appropriate options.
- 8 Navigate to LINE END-PC.D
- 9 Select one of the following the end-of-line settings:
 - **<TAB>** to write into the same row (e.g., in Excel).
 - **<CR><LF>** to write into the same column (e.g., in Excel).
- 10 Press  to confirm your selection.

5.6 Passcode protection

Passcode protection allows you to secure the balance settings. The passcode can have up to eight digits.

Setting up a passcode



- 1 Access the settings menu by pressing .
- 2 Select BAL.SET and confirm with .
- 3 Scroll down and select GENERAL.
- 4 Go to ACCESS PROTECTION.
- 5 Select ON.
- 6 Enter a passcode.
- 7 Press and hold down  to confirm the passcode.
 -  **Note** If a passcode of less than eight digits is entered, the code will be confirmed with unused digits displayed as zeros.
- 8 Check the passcode and press  again.
 - ➔ The settings menu is secured by the passcode.

Resetting the passcode

- 1 Contact your METTLER TOLEDO service representative.

- 2 Provide the following information:
 - serial number (to be found in BAL.INF)
 - date displayed on the balance (press and hold  to show the date in the upper left corner of the display)
 - 3 Enter the provided service passcode (valid for three days).
- ➔ The access protection of the settings menu is deactivated.

Removing the passcode



- 1 Press  and select BAL.SET.
 - 2 Enter the passcode.
 - 3 Press and hold .
 - 4 Scroll down and select "GENERAL.
 - 5 Select ACCESS PROTECTION.
 - 6 Select OFF.
 - 7 Press  to go back to the main weighing screen.
- ➔ The passcode is removed.

5.7 Recall weight

With the recall weight functionality, you can retrieve the last stable weight after the sample has been removed from the balance.

In the manual mode, the weight can be recalled by pressing  after the sample has been removed from the balance.















In the automatic mode, the balance displays the last stable weight value automatically for five seconds as soon as you remove the weight from it. Also, it can recall the last stable weight by pressing .



- 1 Access the settings menu by pressing .
 - 2 Select BAL.SET and confirm with .
 - 3 Select WEIGHING.
 - 4 Scroll down and select RECALL WEIGHT.
 - 5 Select ON and confirm with .
 - 6 Select RECALL WEIGHT MODE.
 - 7 Select MANUAL for the manual mode or AUTO for the automatic mode.
- ➔ The recall weight functionality is switched on.

5.8 Exporting data to a USB storage device

















This function allows you to export the weighing data to a USB storage device in the file formats TXT and CSV, which can be used to transfer the data to a computer.

Exporting weighing data

- 1 Insert the USB storage device.
- 2 Make sure the connectivity icon  is visible in the screen.
- 3 Press  to enter the settings menu.
- 4 Press  or  to select BAL.SET.
- 5 Press  to confirm your selection.
- 6 Press  or  to select PUBLISH.
- 7 Press  to confirm your selection.
- 8 Press  or  to select EXPORT FILE.
- 9 Press  to confirm your selection.
- 10 Press  or  to select ON.
- 11 Press  to confirm your selection.

- 12 Press  to go back to the main weighing screen.
- 13 Weigh a few samples and press  to transfer the result to the USB storage device.
 - ➔ The symbol  appears to indicate that data transfer is in progress.
- NOTICE: Do not remove the USB storage device as long as the symbol is displayed.**
- 14 Remove the USB storage device and view the data on your computer.

Exporting configuration data







- 1 Insert the USB storage device.
- 2 Make sure the connectivity icon  is visible in the screen.
- 3 Press  to enter the settings menu.
- 4 Press  or  to select BAL.SET.
- 5 Press  to confirm your selection.
- 6 Press  or  to select MAINT.
- 7 Press  to confirm your selection.
- 8 Press  or  to select EXPORT.
- 9 Press  to confirm your selection.
 - ➔ START is preselected.
- 10 Press  to confirm your selection.
- 11 Press  or  to select one of the following options:
 - BAL+APP to export the balance and application settings
 - BAL to export the balance settings
 - APP to export the application settings
- 12 Press  to confirm your selection.
- 13 Wait until the export is complete.
- 14 Press  to go back to the main weighing screen.
- 15 Remove the USB storage device.
- 16 Insert the USB storage device on your computer
- 17 Check if the file (.jne) was successfully transferred.
 - ➔ The balance and/or application settings can now be imported to another MA balance model, provided that model and software version of both balances are identical.

6 Software Description







6.1 Menu navigation

After the balance has been switched on, the operation keys can be used to navigate the balance menu.

Navigating the settings menu





- 1 Press  to enter the settings menu.
- 2 Press  or  to navigate between different menu entries.
- 3 Press  to confirm your selection.
 - ➔ The selected menu entry opens. From there you can navigate to the next level of menus.
- 4 Press  to go back one menu level.
- 5 Press  to exit the current menu and return to the main weighing screen of the current application.

Navigating the applications menu

- 1 Press  to enter the applications menu.
- 2 Press  or  to navigate between different applications.
- 3 Press  to exit the applications menu.
- 4 Press  to start the selected application.
 - ➔ The selected application opens. For more information on the applications, refer to Weighing applications.
- 5 Press  to exit the applications menu and return to the main weighing screen of the last used application.

Adapting values

Some values can be adapted. In this case the first digit is blinking. You can start by adapting the first digit.

- 1 Press  to increase the value of the digit.
- 2 Press  to decrease the value of the digit.
- 3 When the desired number is displayed, press  to confirm the first digit.
 - ➔ The balance changes to the next digit. This digit is now blinking.
- 4 Repeat adapting the digits. Confirm each digit by pressing .
- 5 Press  after adapting the last digit to confirm the entered value.
 - ➔ The value has been adapted and can now be used for further operations.

6.2 Menu entries

Applications menu

Pressing  will access the applications menu, where you can choose from a selection of applications







Menu entry	Name of application	Description
WEIGHING	Weighing	[Application "Weighing" ▶ Page 32]
COUNTING	Piece counting	[Application "Piece Counting" ▶ Page 33]
PERCENT	Percent weighing	[Application "Percent weighing" ▶ Page 34]
FORMULA	Formulation	[Application "Formulation" ▶ Page 36]
DYNAMIC	Dynamic weighing	[Application "Dynamic Weighing" ▶ Page 37]
DENSITY	Density determination	[Application "Density" ▶ Page 38]
CHECK	Check weighing	[Application "Check weighing" ▶ Page 40]
FACTOR	Factor weighing	[Application "Factor weighing" ▶ Page 42]
STAT	Statistics	[Application "Statistics" ▶ Page 43]
TOTALING	Totaling	[Application "Totaling" ▶ Page 44]

Settings menu

Pressing  will access the settings menu, where you can make general and application specific settings. Additionally you can look up general information about the balance.

Menu entry	Name of application	Description
APP.SET	Application Settings	The APP.SET menu offers different settings depending on the active weighing application. The applications "FORMULA", "STAT" and "TOTALING" do not offer any application settings.
BAL.SET	Balance Settings	The BAL.SET menu offers general settings of the balance. [Balance settings ▶ Page 57]
BAL INFO	Balance Information	The BAL INFO menu offers information about the balance. [Balance information ▶ Page 63]

See also

-  Settings: Weighing ▶ Page 54
-  Settings: Piece Counting ▶ Page 55
-  Settings: Dynamic Weighing ▶ Page 55
-  Settings: Density ▶ Page 56
-  Settings: Check Weighing ▶ Page 56
-  Settings: Percent Weighing ▶ Page 55
-  Settings: Factor weighing ▶ Page 57

6.3 Application settings

6.3.1 Settings: Weighing

Navigation:  > WEIGHING >  > APP.SET

Menu entry	Description	Values and meaning
SAMPLE ID	Defines a sample identification.	<ul style="list-style-type: none">• ON: Activates sample identification.• OFF*: Deactivates sample identification. Only if SAMPLE ID is set to ON: <ul style="list-style-type: none">• SAMPLE ID NUMBER: Allows you to enter a specific sample identification for the next weighing operation.• AUTOINCREMENT:<ul style="list-style-type: none">– ON*: The balance increments the sample identification automatically by 1 for the next weighing operation.– OFF: The entered sample identification is used for all subsequent samples.

* Factory setting

6.3.2 Settings: Piece Counting

Navigation:  > **PIECE COUNTING** >  > **APP.SET**

Menu entry	Description	Values and meaning
AVG.WGT	Determines the method for setting the average weight of a single piece.	<ul style="list-style-type: none"> MANUAL: Determines the readability for the average weight. <ul style="list-style-type: none"> REFERENCE WEIGHT: Weight of one piece put on the weighing pan. Default: 100d* MEASURE: Determines the reference quantity on which the average weight is based. <ul style="list-style-type: none"> REFERENCE PIECES: Number of pieces put on the weighing pan. Default: 10 pcs*
UNIT	Determines the unit of the reference weight.	The available units are country-specific and depend on the balance model. Default: g*
SAMPLE ID	Allows to define a sample identification.	[Settings: Weighing ▶ Page 54]

* Factory setting

6.3.3 Settings: Percent Weighing

Navigation:  > **PERCENT** >  > **APP.SET**

Menu entry	Description	Values and meaning
REF.WGT	Defines the reference weight. This weight corresponds to 100 %. The weighing result is displayed as a percentage of the entered weight.	<ul style="list-style-type: none"> MANUAL: Set the reference weight manually (enter 100%). <ul style="list-style-type: none"> Default: 1000d* MEASURE: Set the reference weight by weighing an object (weigh 100%).
SAMPLE ID	Allows to define a sample identification.	[Settings: Weighing ▶ Page 54]

* Factory setting

See also

 Settings: Weighing ▶ Page 54

6.3.4 Settings: Dynamic Weighing

Navigation:  > **DYNAMIC** >  > **APP.SET**

Menu entry	Description	Values and meaning
START MODE	Determines the start mode of the dynamic weighing process.	<ul style="list-style-type: none"> MANUAL: Start the weighing process by pressing . AUTO*: The weighing process automatically starts after a defined time once you place an object on the weighing pan.
MEASURING DURATION	Defines the measuring duration in seconds.	Default: 10 s*

Menu entry	Description	Values and meaning
SAMPLE TARE	Activates or deactivates automatic taring between samples.	<ul style="list-style-type: none"> ON: After the result has been calculated, the balance is automatically tared when the sample is removed from the weighing pan. OFF*: Sample tare is deactivated.
SAMPLE ID	Allows to define a sample identification.	[Settings: Weighing ▶ Page 54]

* Factory setting

6.3.5 Settings: Density

Navigation:  > DENSITY >  > APP.SET

Menu entry	Description	Values and meaning
AUXILIARY LIQUID	Determines the auxiliary liquid.	<ul style="list-style-type: none"> H2O*: Choose this setting if the auxiliary liquid is water. CUSTOM: Choose this setting if the auxiliary liquid is not water. <ul style="list-style-type: none"> AUX LIQUID DENSITY: Enter the density of the custom auxiliary liquid here.
TEMPERATURE	Serves to enter the measured temperature of the auxiliary liquid.	Default: 20 °C*
SAMPLE ID	Allows to define a sample identification.	[Settings: Weighing ▶ Page 54]

* Factory setting

6.3.6 Settings: Check Weighing

Navigation:  > CHECK WEIGHING >  > APP.SET

Menu entry	Description	Values and meaning
TARGET.W	Serves to set the target weight manually or by measurement.	<ul style="list-style-type: none"> MANUAL: Set the target weight manually. <ul style="list-style-type: none"> Default: 1000d* MEASURE: Set the target weight by weighing an object.
+/- TOLERANCES	Serves to set the upper and lower limits in percentage.	Default: 2.5%*
TOLERANCES UNIT	Determines the method that the balance uses to calculate the tolerance.	<ul style="list-style-type: none"> %*: Percentage as a measuring method for the tolerance. Example: If in parameter "TOLERANCES" the number "5" is entered, the tolerance is 5%. g: Weight unit as a measuring method for the tolerance. Example: If in parameter "TOLERANCES" the number "5" is entered, the tolerance is 5 g.
SAMPLE ID	Allows to define a sample identification.	[Settings: Weighing ▶ Page 54]

* Factory setting

6.3.7 Settings: Factor weighing

Navigation:  > **FACTOR** >  > **APP.SET**

Menu entry	Description	Values and meaning
METHOD UPON GRAM	Adapts the operation performed with the measured weight.	<ul style="list-style-type: none"> MULTIPLY*: Multiplies the measured weight with the defined factor value. DIVIDE: Divides the measured weight by the defined factor value. PLUS: Adds the defined factor value to the measured weight. MINUS: Subtracts the defined factor value from the measured weight.
DISPLAY DECIMAL	Adapts the displayed decimal places.	Default: 1d*
FACTOR VALUE	Adapts the factor value. The measured weight will be multiplied or divided by this value or the value will be added to or subtracted from the measured weight.	Default: 1*
SAMPLE ID	Allows to define a sample identification.	[Settings: Weighing ▶ Page 54]

* Factory setting

See also

 Settings: Weighing ▶ Page 54

6.4 Balance settings

WEIGHING

Navigation:  > **BAL.SET** > **WEIGHING**

Use this menu to adapt the general settings of weighing processes and overall balance settings.

Menu entry	Description	Values and meaning
MAIN UNIT	Adapts the main weight unit. Weighing results are initially displayed in this unit.	UNIT 1: Sets the main weight unit. The available units depend on the balance model. Default: g*
SECONDARY UNIT	Adapts the secondary weight unit. Displaying of weighing results can be switched between the main unit and the secondary unit.	UNIT 2: Sets the secondary weight unit. The available units depend on the balance model. Default: g*
ENVIRONMENT	Defines the environmental conditions of the balance.	<ul style="list-style-type: none"> V.STABLE: For an environment that is free from any drafts and vibrations. STABLE: For an environment that is practically free from drafts and vibrations. STANDARD*: For an average working environment subject to moderate variations in the ambient conditions. UNSTABLE: For an environment where the conditions are from time to time changing. V.UNSTABLE: For an environment where the conditions are continuously changing.

Menu entry	Description	Values and meaning
WEIGHING MODE	Adapts the weighing mode.	<ul style="list-style-type: none"> • UNIVERS*: For all common weighing procedures. • SNSR.MODE: Delivers a filtered weighing signal of varying strength, depending on the setting of the ambient conditions. Filter has linear characteristic in relation to time (not adaptive) and is suitable for continuous measured value processing.
VALUE RELEASE MODE	Defines the speed at which the balance regards the measured value as stable and available for capture.	<ul style="list-style-type: none"> • V.RLBL.: Very reliable. Provides very good repeatability of the measured results but prolongs the stabilization time. Some intermediate settings can also be chosen from. • RELIABLE • RLBL.FAST* • FAST • V.FAST: Recommended if you require fast results and repeatability is not very important.
DISPLAY READABILITY	Determines the readability [d] of the balance display.	<ul style="list-style-type: none"> • 1d*: Shows the maximum readability. • 10d: 10 times smaller readability <p>The available readability options depend on the balance model.</p>
ZERO DRIFT COMP	<p>Activates or deactivates zero drift compensation.</p> <p>The function Zero drift compensation performs ongoing corrections of deviations from zero which may occur, for example, as a result of small amounts of dirt on the weighing pan.</p> <p>This menu option is not available for "Approved balances", as the settings are predefined.</p>	<ul style="list-style-type: none"> • ON: Zero drift compensation is activated. • OFF: Zero drift compensation is deactivated. <p>The default value depends on the balance model.</p>
SERVICE REMINDER	Activates or deactivates the service reminder function.	<ul style="list-style-type: none"> • ON*: Service reminder is activated. • OFF: Service reminder is deactivated.
ADJUSTMENT	Activates or deactivates manual adjustment.	<ul style="list-style-type: none"> • ON*: Adjustment is activated. • OFF: Adjustment is deactivated.
RECALL WEIGHT	<p>Activates or deactivates the recall-weight function which displays the last weighing result.</p> <p>Stable weights with an absolute display value bigger than 10d are stored.</p>	<ul style="list-style-type: none"> • ON: Recall weight is activated. • OFF*: Recall weight is deactivated. <p>Only if RECALL WEIGHT is set to ON:</p> <ul style="list-style-type: none"> • MANUAL*: The last weighing result can displayed by pressing ✓. • AUTO: The last weighing result is displayed automatically for five seconds after removal of the weighing object.
AUTOMATIC TARE	Activates or deactivates automatic taring.	<ul style="list-style-type: none"> • ON: The first stable weight after a zero is automatically tared. Valid after any zero (including initial zero). • OFF: Automatic tare is deactivated. <p>The default value depends on the balance model.</p>

* Factory setting

PUBLISH

Navigation:  > **BAL.SET** > **PUBLISH**

Use this menu to select and adjust publishing options.

Menu entry	Description	Values and meaning
WEIGHT CAPTURE MODE	Defines the result data transfer behavior. Data can be transferred manually or automatically.	<ul style="list-style-type: none"> • MAN.STABL.*: Manually triggered transfer. The balance waits for a stable weight. • MAN.ALL: Manually triggered transfer. The balance transfers all weighing results. • AUTO.W/OZ: The results are published as soon as the weight is stable. Values of 0 g are not published. • AUTO: The results are published as soon as the weight is stable. Values of 0 g are published.
INTERVAL	Activates or deactivates a time interval between result data transfers.	<ul style="list-style-type: none"> • ON: Activates the time interval between result data transfers. <ul style="list-style-type: none"> – INTERVAL IN SECONDS: Defines the duration of the interval in seconds. • OFF*:: The time interval between result data transfers is deactivated.
EXPORT FILE	Determines if an export file is created.	<ul style="list-style-type: none"> • ON: Export file is used. • OFF*: No export file is used.
WORKFLOW RESULTS	Adapts the trigger for publishing workflow results.	<ul style="list-style-type: none"> • AUTO*: The results are published as soon as the workflow is finished. • MANUAL: Manually triggered transfer of workflow results.
ADJUSTMENT RESULTS	Adapts the trigger for publishing adjustment results.	<ul style="list-style-type: none"> • AUTO: The results are published as soon as the adjustment is finished. • MANUAL*: Manually triggered transfer of adjustment results.
PRINT APPRO BRACKE	Activates or deactivates publishing of approval brackets. This function is only available for approved balances.	<ul style="list-style-type: none"> • ON: Approval brackets are published. • OFF*: Publishing of approval brackets is deactivated.

* Factory setting

REPORT

Navigation: > BAL.SET > REPORT

Use this menu to adapt the data included and the format of the generated report.

Menu entry	Description	Values and meaning
HEADER	Adapts the content of the report header.	<ul style="list-style-type: none">• DATE/TIME<ul style="list-style-type: none">– ON: Includes date and time in the header.– OFF*: Excludes date and time from the header.• BALANCE INFO<ul style="list-style-type: none">– ON: Includes balance information (for example, Balance ID) in the header.– OFF*: Excludes balance information from the header.• APPLICATION INFO<ul style="list-style-type: none">– ON: Includes the application used for the weighing operation in the header.– OFF*: Excludes the application used for the weighing operation from the header.
RESULT	Adapts additional information about the result in the report.	<ul style="list-style-type: none">• TARE/GROSS WEIGHT<ul style="list-style-type: none">– ON: Includes the gross weight for multiple cumulative weighing operations in the result.– OFF*: Excludes the gross weight for multiple cumulative weighing operations from the result.• SECONDARY UNIT<ul style="list-style-type: none">– ON: Includes the weighing result in the secondary unit.– OFF*: Excludes the weighing result from the secondary unit.
FOOTER	Adapts the content of the report footer.	<ul style="list-style-type: none">• DATE/TIME<ul style="list-style-type: none">– ON: Includes date and time in the footer.– OFF*: Excludes date and time from the footer.• SIGNATURE LINE<ul style="list-style-type: none">– ON: Includes the signature line in the footer.– OFF*: Excludes the signature line from the footer.• EMPTY LINES<ul style="list-style-type: none">– ON: Includes empty lines in the footer. This guarantees some space before the next report.– OFF*: Excludes empty lines from the footer.

* Factory setting

INT.FACE

Navigation: > BAL.SET > INT.FACE

Use this menu to select and define specific interface options.

Menu entry	Description	Values and meaning
RS232	Adapts the settings for the RS232 interface.	<ul style="list-style-type: none"> • RS232 CONNECTION <ul style="list-style-type: none"> – CMD.HOST – P-20: printer – P-50: printer – 2.DISPLAY: Notice that the balance can be damaged if other devices besides compatible displays are connected. – PC.DIRECT – EDB: EasyDirect Balance software <p>After selecting the connection type (RS232 CONNECTION) you can define the interface properties. Not all options are available for every connection type.</p> <ul style="list-style-type: none"> • BAUDRATE: Sets the baud rate (600 1200 2400 4800 9600 19200 38400 57600 115200) • BITS/PARITY: Sets the number of bits and the parity bit settings (8/No 7/No 7/Mark 7/Space 7/Even 7/Odd • DATA FLOW: Sets the data flow options (XOn/XOff RTC / CTS NONE) • STOP BIT: Sets stop bit options (1-bit 2 bits) • LINE END: Sets the line end ((CR) (LF) (CR) (LF) (TAB)) (CR) (LF)): Writes in the same column. (TAB): Writes in the same row. • COMMAND SET: Sets the command set (MT-SICS SART.16 SART.22) MT-SICS): MT-SICS data transfer format is used. SART.16 / SART.22: Emulated Sartorius balances data format is used. • HOST OUTPUT MODE: Sets the output mode (SINGLE CONT) SINGLE: A single data package is sent. CONT.: The data package is repeated continuously. • WEIGHT UNIT: Activates or deactivates the transfer of the selected weight unit. PC.DIRECT only.
USB	Adapts settings for the USB interface.	<ul style="list-style-type: none"> • USB CONNECTION <ul style="list-style-type: none"> – USB D.S.: Activates USB protocol for data transfer. – RS232 D.S.: Activates RS232 protocol for data transfer. • CONNECTED DEVICE: Lists connected devices found. If no compatible device is connected NO FOUND is displayed.

Menu entry	Description	Values and meaning
COMMUNICATION	Activates or deactivates data transfer.	<ul style="list-style-type: none"> COMMUNICATION <ul style="list-style-type: none"> ACTIVE*: The selected interface connection is transferring data. BLOCKED: Balance communication is blocked.

* Factory setting

DATE.TIME

Navigation:  > **BAL.SET** > **DATE.TIME**

Use this menu to set date and time.

Menu entry	Description	Values and meaning
DATE FORMAT	Adapts the date format.	<ul style="list-style-type: none"> DD.MM.YYYY* MM / DD / YY YY - MM - DD YY / MM / DD
DATE	Sets the balance date.	<ul style="list-style-type: none"> DATE/DAY DATE/MONTH DATE/YEAR
TIME FORMAT	Adapts the time format.	<ul style="list-style-type: none"> 24:MM*: Sets a 24 h format with colon as separator between hours and minutes. 12:MM: Sets a 12 h format with colon as separator between hours and minutes. 24.MM: Sets a 24 h format with period as separator between hours and minutes. 12.MM: Sets a 12 h format with period as separator between hours and minutes.
TIME	Sets the balance time.	<ul style="list-style-type: none"> TIME/HOURS TIME/MINUTES

* Factory setting

GENERAL

Navigation:  > **BAL.SET** > **GENERAL**

Use this menu to display the balance identifier and to set up protection against unauthorized access.

Menu entry	Description	Values and meaning
BACKLIGHT	Activates or deactivates the display backlight.	<ul style="list-style-type: none"> ON*: Backlight is activated. OFF: Backlight is deactivated.
SOUND ON KEY PRESS	Activates or deactivates acoustic feedback.	<ul style="list-style-type: none"> ON*: Pressing a key is indicated by a beeping sound. OFF: Sounds are deactivated.
BALANCE ID	Sets a balance identifier.	—
ACCESS PROTECTION	Restricts access to some balance menus by establishing a passcode.	<ul style="list-style-type: none"> ON: Passcode protection is activated. Access some menus is restricted. [Passcode protection ► Page 50] OFF*: Passcode protection is deactivated.
AUTO STANDBY	Activates or deactivates automatic standby.	<ul style="list-style-type: none"> ON*: The balance automatically enters standby mode after a defined time. OFF: Standby mode will not be activated automatically.

Menu entry	Description	Values and meaning
WAIT TIME IN	Defines the time in seconds until standby mode is entered. Does not apply to compact balances in battery mode.	Default: 10*

* Factory setting

MAINT

Navigation:  > **BAL.SET** > **MAINT**

Use this menu to update the software or to reset the balance.

Menu entry	Description	Values and meaning
DATA AND SETTINGS	Exports data and settings to a USB storage device or imports existing data.	<ul style="list-style-type: none"> • IMPORT • EXPORT
SOFTWARE	Updates the balance software or displays the software version log.	<ul style="list-style-type: none"> • UPDATE: Performs a software update. [Updating the software ► Page 71] • LOG: Displays the software version log.
RESET	Resets the balance software.	–

See also

 Settings: Weighing ► Page 54

6.5 Balance information

Navigation:  > **BAL.INFO**

Menu entry	Description	Values and meaning
BALANCE TYPE	This menu item shows the type of the balance.	–
BALANCE ID	This menu item shows the ID of the balance.	–
MAXIMUM CAPACITY	This menu item shows the maximum capacity of the scale.	–
SCALE INTERVAL	The scale interval in grams.	–
SERIAL NUMBER 1/2	The first 8 digits of the 9-digit serial number.	–
SERIAL NUMBER 2/2	The last digit of the 9-digit serial number.	–
SOFTWARE SYSTEM	The version of the installed software.	–
DIGITAL LOAD CELL	The software version of the digital load cell.	–
TDNR 1/2	First part of the type definition number. The type definition number is the key to a defined set of configuration parameters of the balance.	–
TDNR 2/2	Second part of the type definition number.	–

6.6 Adjustment settings

Navigation: >  > following menu entry

Menu entry	Description	Values and meaning
ADJ.INT	The internal adjustment uses the built-in weights to adjust the balance.	–
ADJ.EXT	The external adjustment requires separate weights to adjust the balance.	ADJUSTMENT WEIGHT: Defines the weight of your choice.

7 Maintenance

To guarantee the functionality of the balance and the accuracy of the weighing results, a number of maintenance actions must be performed by the user.

7.1 Maintenance tasks

Maintenance action	Recommended interval	Remarks
Performing an adjustment	<ul style="list-style-type: none">• Daily• After cleaning• After leveling• After changing the location	see "Adjustments"
Cleaning	<ul style="list-style-type: none">• After every use• Depending on the degree of pollution• Depending on your internal regulations (SOP)	see "Cleaning"
Updating the software	<ul style="list-style-type: none">• Depending on your internal regulations (SOP).• After a new software release.	see "Software update"

See also

- [Adjustments](#) ▶ Page 45
- [Cleaning](#) ▶ Page 65
- [Software update](#) ▶ Page 71

7.2 Cleaning

7.2.1 Disassembling for cleaning

Note

Depending on the balance model, the components may look different.

Note

In most cases, it is not necessary to remove the protective cover to clean the balance.

7.2.1.1 Balances with draft shield



CAUTION

Injury due to sharp objects or broken glass

Instrument components, e.g., glass, can break and lead to injuries.

- Always proceed with focus and care.

- 1 Fully open the side door (1).
- 2 Remove the weighing pan (2) and the drip tray (3).

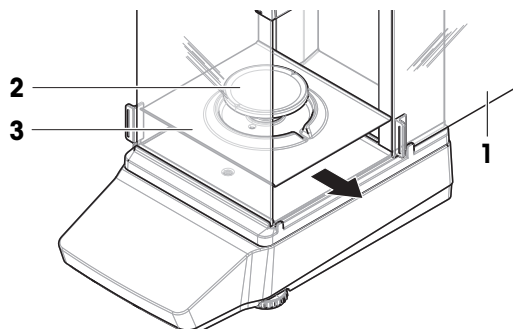

- 3 Turn the quick lock **(4)** and pull the side door **(1)** towards the front to remove it (right, left).

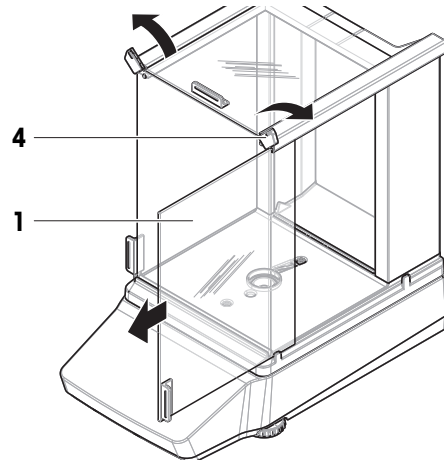

- 4 Tilt the front panel **(5)** towards the front and lift it upwards to remove it.

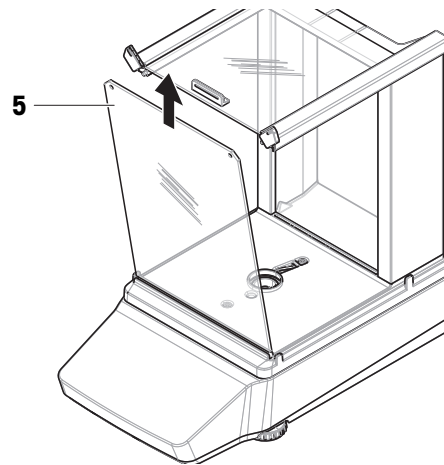

- 5 Pull the top door **(6)** towards the front to remove it.

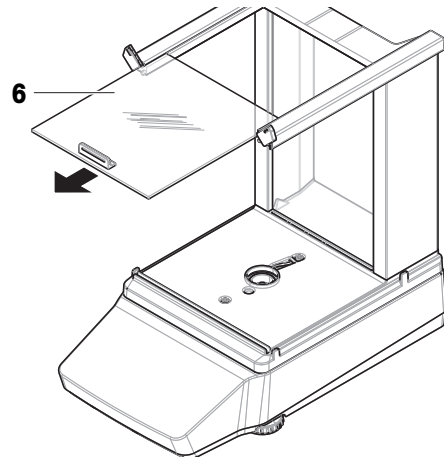

- 6 Press the release button (7) and tilt the back panel (8) to remove it.

Note

Optional, if required: Remove the protective cover for cleaning as described below.

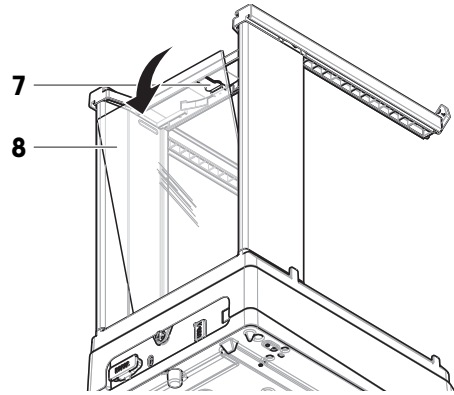

- 7 Remove the front screw (9) and the rear screw (10) with a Phillips screwdriver.
- 8 Remove the draft shield (11).

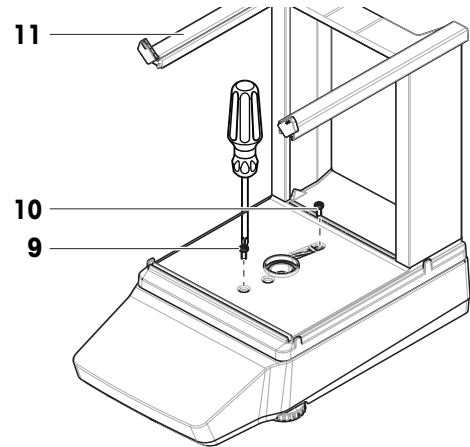

- 9 Remove the protective cover (12) from the platform (13).

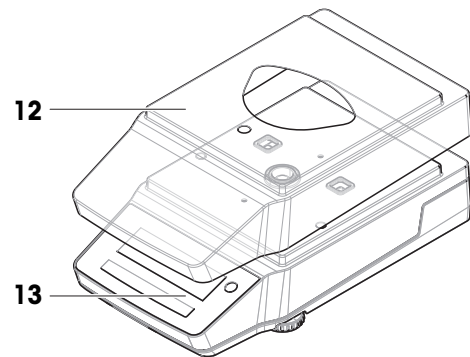

7.2.1.2 Balances without draft shield

- 1 Remove the draft-protection element (1).
- 2 Remove the weighing pan (2).
- 3 Remove the weighing pan support (3).

Note

Optional, if required: Remove the protective cover for cleaning as described below.

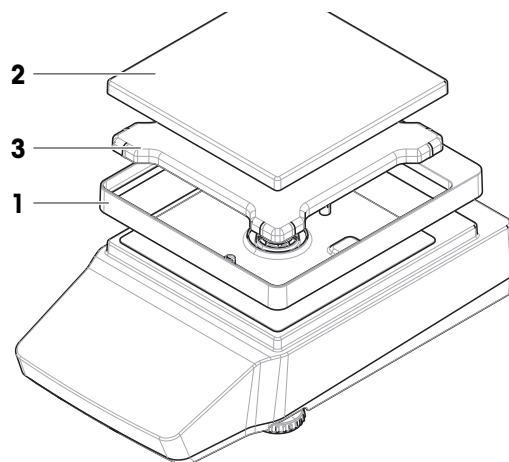

- 4 Remove the screws (4) to remove the EMC plate (5).
- 5 Remove the protective cover (6) from the platform (7).

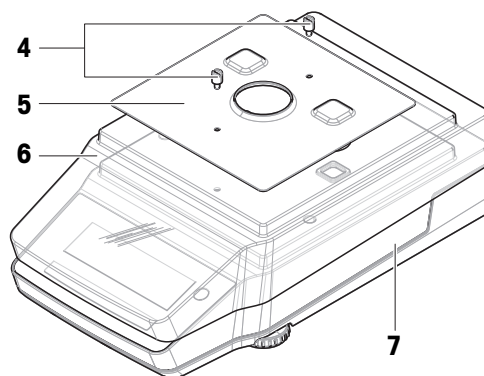

7.2.1.3 Balances, large

- 1 Remove the weighing pan (1).
- 2 Remove the support caps (2).
- 3 Optional, if required: Remove the protective cover (3) for cleaning.

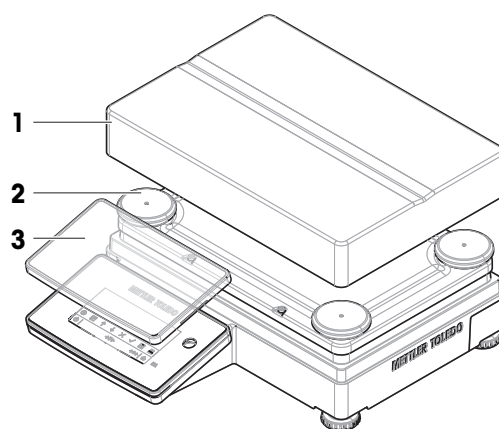

7.2.1.4 Balances, compact

- 1 Remove the weighing pan (1).
- 2 Remove the support caps (2).

Note

Optional, if required: Remove the protective cover for cleaning as described below.

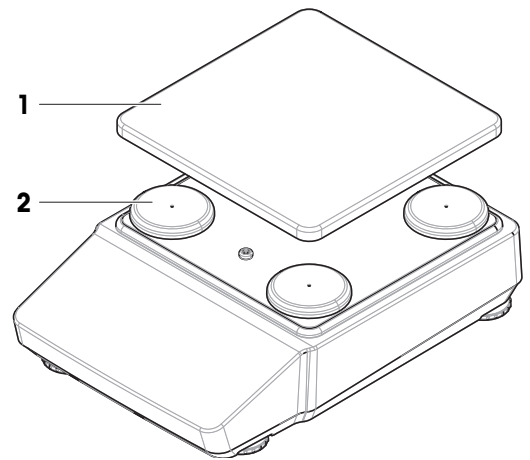

- 3 Remove the screw (4) to remove the EMC plate (5).
- 4 Remove the protective cover (6) from the platform (7).

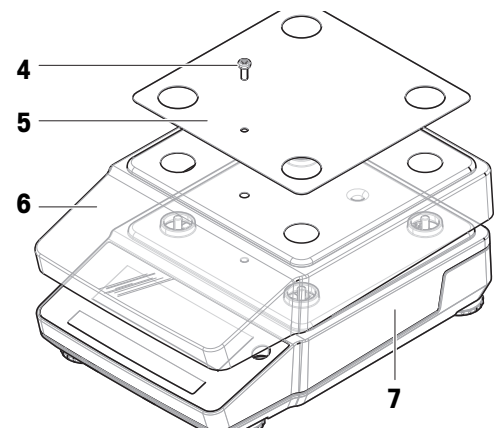

7.2.2 Cleaning agents

In the following table, cleaning tools and cleaning agents recommended by METTLER TOLEDO are listed. Pay attention to the concentration of the agents specified in the table.

		Tools				Cleaning agents					
		Paper tissue	Brush	Dishwasher	Water	Acetone	Ethanol (70%)	Isopropanol (70%)	Hydrochloric acid (3-10%)	Sodium hydroxide (1-4%)	Peracetic acid (2-3%)
Around the balance	Balance housing	✓	✓	-	✓	-	✓	✓	✓	✓	✓
	Feet	✓	✓	-	✓	-	✓	✓	✓	✓	✓
Balance terminal	Terminal	✓	✓	-	✓	PR	✓	✓	✓	✓	✓
	Display	✓	✓	-	✓	PR	✓	✓	✓	✓	✓
	Terminal cover	✓	✓	-	✓	-	✓	✓	✓	PR	PR

		Paper tissue	Brush	Dishwasher	Water	Acetone	Ethanol (70%)	Isopropanol (70%)	Hydrochloric acid (3-10%)	Sodium hydroxide (1-4%)	Peracetic acid (2-3%)
Balance draft shield	Glass panels	✓	✓	✓	✓	PR	✓	✓	✓	✓	✓
	Non-removable handles and frames	✓	✓	—	✓	—	✓	✓	✓	✓	✓
Weighing area	Weighing pan	✓	✓	✓	✓	PR	✓	✓	✓	✓	✓
	Drip tray	✓	✓	✓	✓	PR	✓	✓	—	—	✓
Accessories	Dust cover	✓	✓	—	✓	—	✓	✓	—	—	PR
	Antistatic kit	✓	✓	—	—	—	—	—	—	—	—

Legend

- ✓ Recommended by METTLER TOLEDO; can be used without limitation.
- PR Partially recommended by METTLER TOLEDO: individual resistance to acid and alkali must be evaluated, including dependence to the time exposure.
- Not recommend. High risk for damage.

7.2.3 Cleaning the balance



NOTICE

Damage to the instrument due to inappropriate cleaning methods

If liquid enters the housing, it can damage the instrument. The surface of the instrument can be damaged by certain cleaning agents, solvents, or abrasives.

- 1 Do not spray or pour liquid on the instrument.
- 2 Only use the cleaning agents specified in the Reference Manual (RM) of the instrument or the guide "8 Steps to a Clean Balance".
- 3 Only use a lightly moistened, lint-free cloth or a tissue to clean the instrument.
- 4 Wipe off any spills immediately.



For further information on cleaning a balance, consult "8 Steps to a Clean Balance".

► www.mt.com/lab-cleaning-guide

Cleaning around the balance

- Remove any dirt or dust around the balance and avoid further contaminations.

Cleaning the terminal

- Clean the terminal with a damp cloth or a tissue and a mild cleaning agent.

Cleaning the removable parts

- Clean the removed part with a damp cloth or a tissue and a mild cleaning agent or clean in a dishwasher up to 80 °C.

Cleaning the balance

- 1 Disconnect the balance from the AC/DC adapter.
- 2 Use a lint-free cloth moistened with a mild cleaning agent to clean the surface of the balance.
- 3 Remove powder or dust with a disposable tissue first.
- 4 Remove sticky substances with a damp lint-free cloth and a mild solvent, e.g., isopropanol or ethanol 70%.

7.2.4 Putting into operation after cleaning

- 1 Reassemble the balance.
- 2 Check that the draft shield doors (top, sides) open and close normally (if applicable).
- 3 Reconnect the balance to the AC/DC adapter.
- 4 Check the level bubble, level the balance if necessary.
- 5 Respect the warm-up time specified in the "Technical Data".
- 6 Perform an adjustment.
- 7 Perform a routine test according to the internal regulations of your company.
- 8 Press **→0←** to zero the balance.
 - ➔ The balance is ready for use.

See also

- 🔗 Leveling the balance ▶ Page 25
- 🔗 Technical Data ▶ Page 78
- 🔗 Performing an internal adjustment ▶ Page 27

7.3 Service

Regular servicing by an authorized service technician ensures reliability for years to come. Contact your METTLER TOLEDO representative for details about the available service options.

7.4 Software update

Search for software:

▶ www.mt.com/labweighing-software-download

Contact a METTLER TOLEDO service representative if you need support updating the software.

Navigation: ⚙️ > **BAL.SET** > **MAINT** > **SOFTWARE** > **UPDATE**

7.4.1 Updating the software

The software update is only accessible to users with the corresponding rights. Make sure that the USB storage device used contains only one software in the file format MOT.



NOTICE

Removing USB storage device during software update

Do not remove the USB storage device during the software update procedure. This can lead to an incomplete or faulty installation of the balance software.

- A USB storage device containing the software is connected to the balance.
 - 1 Press ⚙️ to enter the settings menu.
 - 2 Navigate to the menu entry BAL.SET.
 - 3 Navigate to the menu entry MAINT.
 - 4 Navigate to the menu entry SOFTWARE UPDATE.

- ➔ A request to insert a USB storage device is displayed.
- 5 Insert a USB storage device with the desired software version.
- 6 Select START to run the update.
- ➔ The balance performs the update. After completing the update, the balance reboots.

7.4.2 Putting into operation after software update

- 1 Check the level status. Level the balance if required.
- 2 Perform an internal adjustment.
- 3 Press **→0←** to zero the balance.
 - ➔ The balance is ready for use.

See also

- [🔗 Leveling the balance ▶ Page 25](#)
- [🔗 Performing an internal adjustment ▶ Page 27](#)

8 Troubleshooting

Possible errors with their cause and remedy are described in the following chapter. If there are errors that cannot be corrected through these instructions, contact METTLER TOLEDO.

8.1 Error messages

Error message	Possible cause	Diagnostic	Remedy
The balance shows an error code.	Software or hardware error.	–	Restart the balance. If that does not help, perform a balance reset. If the issue persists, contact your METTLER TOLEDO service representative.
DATE AND TIME DATA LOST - CHECK SETTINGS	The battery (capacitor) is low. The backup is lost.	Check the settings for date and time.	Connect the balance to the power outlet and let the battery (capacitor) charge for two to three days. Set date and time. If the issue persists, contact your METTLER TOLEDO service representative.
EEPROM CHECKSUM ERROR	EEPROM is corrupt.	–	Perform a balance reset. If the issue persists, contact your METTLER TOLEDO service representative.
MEMORY FULL	The memory storage is full.	–	Perform a balance reset.
NO STANDARD ADJUSTMENT	The standard adjustment is missing or invalid.	–	Contact your METTLER TOLEDO service representative.
PROGRAM MEMORY DEFECT	The checksum for the stored program is not correct anymore.	–	Reinstall the balance software. If the issue persists, contact your METTLER TOLEDO service representative.
TEMPERATURE SENSOR DEFECT	The temperature sensor that measures the cell temperature is defective.	–	Contact your METTLER TOLEDO service representative.
UNKNOWN ERROR	General error for an unspecific issue.	–	Restart the balance. Perform a balance reset. If the issue persists, contact your METTLER TOLEDO service representative.
WRONG CELL DATA	The cell data is damaged or its checksum is incorrect.	–	Contact your METTLER TOLEDO service representative.

Error message	Possible cause	Diagnostic	Remedy
NO FILE	<p>During software update: No MOT file on the USB storage device.</p> <p>During data import: No JNE file in the folder \METTLER TOLEDO\Export\.</p>	–	<p>Make sure that a USB storage device with a suitable MOT file in the root directory is connected to the USB-A port of the balance.</p> <p>Make sure that a USB storage device with a suitable MOT file in the folder \METTLER TOLEDO\Export\ is connected to the USB-A port of the balance.</p> <p>If the issue persists, contact your METTLER TOLEDO service representative.</p>
APPROVED BALANCE	The software on the USB storage device is not for approved balances.	–	<p>Make sure that the USB storage device contains the correct software for approved balances.</p> <p>If the issue persists, contact your METTLER TOLEDO service representative.</p>
CONFLICTING FILES	<p>During software update: The USB storage device contains more than one suitable MOT file for the present balance.</p> <p>During data import: The USB storage device contains more than one suitable JNE file for the present balance in the folder \METTLER TOLEDO\Export\.</p>	–	<p>Make sure that the USB storage device contains only one suitable MOT file for the present balance.</p> <p>Make sure that the USB storage device contains only one suitable JNE file for the present balance in the folder \METTLER TOLEDO\Export\.</p> <p>If the issue persists, contact your METTLER TOLEDO service representative.</p>
WRITING FAILED	Writing has failed, e.g., because the USB storage device has been damaged or disconnected during export.	–	<p>Make sure that an intact USB storage device is connected to the balance and not disconnected during export.</p> <p>If the issue persists, contact your METTLER TOLEDO service representative.</p>

Error message	Possible cause	Diagnostic	Remedy
NO USB STICK	No USB storage device connected.	–	Make sure that a USB storage device is connected to the USB-A port of the balance. If the issue persists, contact your METTLER TOLEDO service representative.
WRONG FILE	No suitable JNE file in the folder \METTLER TOLEDO\Export\.	–	Make sure that the USB storage device contains the correct JNE file for the present balance in the folder \METTLER TOLEDO\Export\ If the issue persists, contact your METTLER TOLEDO service representative.
WRONG FILE	No suitable MOT file on the USB storage device.	–	Make sure that the USB storage device contains the correct MOT file for the present balance. If the issue persists, contact your METTLER TOLEDO service representative.

8.2 Error symptoms

Error symptom	Possible cause	Diagnostic	Remedy
The balance shows no valid date and time.	The battery (capacitor) is low. The battery (capacitor) backup is lost.	Check the settings for date and time.	Connect the balance to the power outlet and let the battery (capacitor) charge for two to three days. Set date and time. If the issue persists, contact your METTLER TOLEDO service representative.
The display is dark.	There is no power.	Check the connection to the AC/DC adapter and the power outlet.	Connect the balance to the power outlet. See "Connecting the balance".
	The wrong AC/DC adapter is connected to the balance.	Check the AC/DC adapter, see "Technical Data".	Use the correct AC/DC adapter.
	The AC/DC adapter is defective.	–	Replace the AC/DC adapter.
	The display is defective.	–	Contact your METTLER TOLEDO service representative.

Error symptom	Possible cause	Diagnostic	Remedy
The balance does not react to any input.	Software freeze.	—	Disconnect the power cable from the balance and reconnect it after a few seconds. Perform a balance reset. If the issue persists, contact your METTLER TOLEDO service representative.
The balance does not start up properly.	The balance has no power.	Check if the AC/DC adapter is plugged in.	Connect the AC/DC adapter.
	The AC/DC adapter is defective.	Check with another AC/DC adapter if available.	Replace the AC/DC adapter. See "Accessories".
The balance does not return to zero when the weight is removed.	Something is touching the weighing pan. Dirt or dust on the weighing pan.	Remove the weighing pan and check it for dirt or dust.	Clean the weighing pan. If the issue persists, contact your METTLER TOLEDO service representative.
Taring fails.	The weighing bench is vibrating.	Tab →← and check if the value on the display is still unstable.	Place the balance on a weighing bench free of vibrations.
	The weighing sample is electrostatically charged.	Place a test weight on the weighing pan. Check if the weighing result is stable.	For balances with a draft shield: place a water container into the weighing chamber to increase the humidity. Use an antistatic device. See "Accessories".
	The balance is exposed to drafts.	Check the location for sources of draft.	Place the balance in a location without draft.
The internal adjustment fails.	A weight is on the weighing pan.	—	Remove the weight from the weighing pan.
	Repeatability is poor.	—	Perform a repeatability test.
	The internal weight does not function properly.	—	Contact your METTLER TOLEDO service representative.
The display shows overload or underload.	The wrong weighing pan is installed.	Slightly lift or press the weighing pan to see if the weight appears on the display.	Install a proper weighing pan.
	No weighing pan is installed.	—	Install a proper weighing pan.
	Incorrect zero point when the balance is switched on.	—	Disconnect the power cable and reconnect it after a few seconds.
	The balance is not adjusted.	—	Perform an internal adjustment. See "Performing an internal adjustment".

Error symptom	Possible cause	Diagnostic	Remedy
The value on the display oscillates.	Vibrations on the weighing bench, for example, building vibrations, foot traffic.	Place a beaker with water on the weighing bench. Vibrations cause ripples on the water surface.	Protect the weighing location against vibrations, for example, with an absorber. Find a different weighing location.
	Draft due to untight draft shield and/or open window.	Check the draft shield for gaps.	Fix the draft shield. Close the window.
	The weighing sample is electrostatically charged.	Check if the weighing result is stable when using a test weight.	Increase the air humidity in the weighing chamber. Use an ionizer. See "Accessories".
	The location is not suitable for weighing.	–	Follow the requirements for the location. See "Selecting the location".
	Something is touching the weighing pan.	Check for touching parts or dirt.	Remove touching parts. Clean the balance.
The value on the display is drifting towards plus or minus.	The location is not suitable for weighing.	–	Place the balance in a location with suitable environmental conditions.
	The weighing sample absorbs moisture or evaporates moisture.	Check if the weighing result is stable when using a test weight.	Cover the weighing sample.
	The weighing sample is electrostatically charged.	Use a test weight to check if the weighing result is stable.	Increase the humidity in the weighing chamber. Use an ionizer. See "Accessories".
	The weighing sample is warmer or colder than the air in the weighing chamber.	Check if the weighing result is stable when using an acclimatized test weight.	Bring the sample to room temperature.
	The balance has not yet warmed up.	–	Let the balance warm up. Adequate warm-up time is specified in the section "General data".

8.3 Putting into operation after fixing an error

After troubleshooting, perform the following steps to put the balance into operation:

- Ensure that the balance is completely reassembled and cleaned.
- Reconnect the balance to the AC/DC adapter.

9 Technical Data

9.1 General data

Power supply

AC/DC adapter:	Input: 100 – 240 V AC \pm 10%, 50 – 60 Hz, 0.5 A Output: 12 V DC, 1 A, LPS
Balance power consumption:	12 V DC, 0.5 A
Polarity:	

Protection and standards

Overvoltage category:	II
Degree of pollution:	2
Ingress protection code:	IP43 (balances with readability of 0.01 g or higher, excluding compact balances)

Note

Stated IP is only achieved when the balance is ready for operation. The protective cover must be installed, and the caps must cover the interface connections.

Standards for safety and EMC:	See Declaration of Conformity
Range of application:	Use only indoors in dry locations

Environmental conditions

The limit values apply when the balance is used under the following environmental conditions:

Height above mean sea level:	Up to 5000 m
Ambient temperature:	+10 – +30 °C (excluding large balances) +5 – +40 °C (large balances)
Temperature change, max.:	5 °C/h
Relative humidity:	30 – 70%, non-condensing
Acclimatization time:	Recommendation: Up to 4 hours for precision balances, or up to 8 hours for analytical balances. These values apply after placing the balance in the same location where it will be put into operation.

Note

The acclimatization time depends on the readability of the balance, and on the environmental conditions.

Warm-up time:	At least 30 minutes for precision balances, or 60 minutes for analytical balances. These values apply after connecting the balance to the power supply. When switched on from standby, the balance is ready for operation immediately.
---------------	--

The balance can be used under the following environmental conditions. However, the weighing performances of the balance may be outside the limit values:

Ambient temperature:	+5 °C – +40 °C
Relative humidity:	20% to max. 80% at 31 °C, decreasing linearly to 50% at 40 °C, non-condensing

The balance can be disconnected and stored in its packaging under the following conditions:

Ambient temperature:	-25 – +70 °C
Relative humidity:	10 – 90%, non-condensing

9.2 Materials

Housing regular balances:	Bottom housing: die-cast aluminum Top housing: PBT Housing frame: POM
Housing large balances:	Bottom housing, top housing and terminal frame: die-cast aluminum, powder-coated Housing frame: POM
Housing compact balances:	ABS/PC
Draft shield:	POM (U-shaped top frame), PBT (bottom plate), glass (doors, front panel), powder-coated aluminum (posts), PA 12 (handles)
Weighing pan:	∅ 80 mm and ∅ 90 mm: stainless steel X2CrNiMo17-12-2 (1.4404) All others: stainless steel X5CrNi18-10 (1.4301)
Drip tray:	Stainless steel X2CrNiMo17-12-2 (1.4404)
Draft-protection element:	PBT
Touchscreen:	Glass
Protective cover:	PET
Feet regular and large balances:	TPE, stainless steel X5CrNi18-10 (1.4301)
Feet compact balances:	ABS/PC, stainless steel X5CrNi18-10 (1.4301)

9.3 Model-specific data

i Note

Balances with the letter E in their model designation use external adjustment only. These balances do not have internal adjustment as an option.

9.3.1 Analytical balances, readability 0.01 mg or 0.1 mg

	MA55	MA95	MA155DU
Limit values			
Capacity	52 g	92 g	152 g
Nominal load	50 g	80 g	150 g
Readability	0.01 mg	0.01 mg	0.1 mg
Capacity of fine range	–	–	62 g
Readability in fine range	–	–	0.01 mg
Repeatability (at 5% load)	0.03 mg	0.03 mg	0.03 mg
Linearity deviation	0.1 mg	0.1 mg	0.2 mg
Eccentricity deviation (at test load)	0.1 mg (20 g)	0.1 mg (50 g)	0.1 mg (50 g)
Sensitivity offset (at nominal load) ▲	0.4 mg	0.4 mg	0.8 mg
Sensitivity temperature drift	0.0002%/°C	0.0002%/°C	0.0002%/°C
Typical values			
Repeatability (at 5% load)	0.015 mg	0.015 mg	0.015 mg
Linearity deviation	0.03 mg	0.03 mg	0.06 mg
Eccentricity deviation (at test load)	0.03 mg (20 g)	0.03 mg (50 g)	0.03 mg (50 g)
Sensitivity offset (at nominal load) ▲	0.25 mg	0.25 mg	0.5 mg
Minimum weight (USP, tolerance = 0.10%) ▼	30 mg	30 mg	30 mg
Minimum weight (tolerance = 1%) ▼	3 mg	3 mg	3 mg
Settling time	4 s	4 s	4 s
Dimensions and other specifications			
Balance dimensions (W × D × H)	209 × 354 × 354 mm	209 × 354 × 354 mm	209 × 354 × 354 mm
Weighing pan diameter	80 mm	80 mm	80 mm
Usable height of draft shield	238 mm	238 mm	238 mm
Balance weight	5.6 kg	5.6 kg	5.6 kg
Weights for routine testing			
Weights (OIML class)	50 g (F2) / 2 g (F2)	50 g (F2) / 2 g (F2)	100 g (F2) / 5 g (F2)
Weights (ASTM class)	50 g (ASTM 1) / 2 g (ASTM 1)	50 g (ASTM 1) / 2 g (ASTM 1)	100 g (ASTM 1) / 5 g (ASTM 1)

▲ after adjustment with internal weight

▼ determined at 5% load, k = 2

	MA54	MA54E	MA104	MA104E
Limit values				
Capacity	52 g	52 g	120 g	120 g
Nominal load	50 g	50 g	100 g	100 g
Readability	0.1 mg	0.1 mg	0.1 mg	0.1 mg
Repeatability (at 5% load)	0.1 mg	0.1 mg	0.1 mg	0.1 mg
Linearity deviation	0.2 mg	0.2 mg	0.2 mg	0.2 mg
Eccentricity deviation (at test load)	0.4 mg (20 g)	0.4 mg (20 g)	0.4 mg (50 g)	0.4 mg (50 g)
Sensitivity offset (at nominal load) ▲	0.3 mg	0.3 mg	0.5 mg	0.5 mg
Sensitivity temperature drift	0.0002%/°C	0.0002%/°C	0.0002%/°C	0.0002%/°C
Typical values				
Repeatability (at 5% load)	0.08 mg	0.08 mg	0.08 mg	0.08 mg
Linearity deviation	0.06 mg	0.06 mg	0.06 mg	0.06 mg
Eccentricity deviation (at test load)	0.12 mg (20 g)	0.12 mg (20 g)	0.12 mg (50 g)	0.12 mg (50 g)
Sensitivity offset (at nominal load) ▲	0.15 mg	–	0.3 mg	–
Minimum weight (USP, tolerance = 0.10%) ▼	160 mg	160 mg	160 mg	160 mg
Minimum weight (tolerance = 1%) ▼	16 mg	16 mg	16 mg	16 mg
Settling time	2 s	2 s	2 s	2 s
Dimensions and other specifications				
Balance dimensions (W × D × H)	209 × 354 × 354 mm	209 × 354 × 354 mm	209 × 354 × 354 mm	209 × 354 × 354 mm
Weighing pan diameter	90 mm	90 mm	90 mm	90 mm
Usable height of draft shield	238 mm	238 mm	238 mm	238 mm
Balance weight	5.6 kg	5.4 kg	5.6 kg	5.4 kg
Weights for routine testing				
Weights (OIML class)	50 g (F2) / 2 g (F2)	50 g (F2) / 2 g (F2)	100 g (F2) / 5 g (F2)	100 g (F2) / 5 g (F2)
Weights (ASTM class)	50 g (ASTM 1) / 2 g (ASTM 1)	50 g (ASTM 1) / 2 g (ASTM 1)	100 g (ASTM 1) / 5 g (ASTM 1)	100 g (ASTM 1) / 5 g (ASTM 1)

▲ after adjustment with internal weight

▼ determined at 5% load, k = 2

	MA204	MA204E
Limit values		
Capacity	220 g	220 g
Nominal load	200 g	200 g
Readability	0.1 mg	0.1 mg
Repeatability (at 5% load)	0.1 mg	0.1 mg
Linearity deviation	0.2 mg	0.2 mg
Eccentricity deviation (at test load)	0.4 mg (100 g)	0.4 mg (100 g)
Sensitivity offset (at nominal load) ▲	0.8 mg	0.8 mg
Sensitivity temperature drift	0.0002%/°C	0.0002%/°C
Typical values		
Repeatability (at 5% load)	0.08 mg	0.08 mg
Linearity deviation	0.06 mg	0.06 mg
Eccentricity deviation (at test load)	0.12 mg (100 g)	0.12 mg (100 g)
Sensitivity offset (at nominal load) ▲	0.5 mg	–
Minimum weight (USP, tolerance = 0.10%) ▼	160 mg	160 mg
Minimum weight (tolerance = 1%) ▼	16 mg	16 mg
Settling time	2 s	2 s
Dimensions and other specifications		
Balance dimensions (W × D × H)	209 × 354 × 354 mm	209 × 354 × 354 mm
Weighing pan diameter	90 mm	90 mm
Usable height of draft shield	238 mm	238 mm
Balance weight	5.6 kg	5.4 kg
Weights for routine testing		
Weights (OIML class)	200 g (F2) / 10 g (F2)	200 g (F2) / 10 g (F2)
Weights (ASTM class)	200 g (ASTM 1) / 10 g (ASTM 1)	200 g (ASTM 1) / 10 g (ASTM 1)

▲ after adjustment with internal weight

▼ determined at 5% load, k = 2

9.3.2 Precision balances, readability 1 mg

	MA103	MA103E	MA203	MA203E
Limit values				
Capacity	120 g	120 g	220 g	220 g
Nominal load	100 g	100 g	200 g	200 g
Readability	1 mg	1 mg	1 mg	1 mg
Repeatability (at 5% load)	1 mg	1 mg	1 mg	1 mg
Linearity deviation	2 mg	2 mg	2 mg	2 mg
Eccentricity deviation (at test load)	4 mg (50 g)	4 mg (50 g)	4 mg (100 g)	4 mg (100 g)
Sensitivity offset (at nominal load) ▲	6 mg	6 mg	8 mg	8 mg
Sensitivity temperature drift	0.0003%/°C	0.0003%/°C	0.0003%/°C	0.0003%/°C
Typical values				
Repeatability (at 5% load)	0.7 mg	0.7 mg	0.7 mg	0.7 mg
Linearity deviation	0.6 mg	0.6 mg	0.6 mg	0.6 mg
Eccentricity deviation (at test load)	1.2 mg (50 g)	1.2 mg (50 g)	1.2 mg (100 g)	1.2 mg (100 g)
Sensitivity offset (at nominal load) ▲	4 mg	–	5 mg	–
Minimum weight (USP, tolerance = 0.10%) ▼	1.4 g	1.4 g	1.4 g	1.4 g
Minimum weight (tolerance = 1%) ▼	140 mg	140 mg	140 mg	140 mg
Settling time	1.5 s	1.5 s	1.5 s	1.5 s
Dimensions and other specifications				
Balance dimensions (W × D × H)	209 × 354 × 354 mm	209 × 354 × 354 mm	209 × 354 × 354 mm	209 × 354 × 354 mm
Weighing pan diameter	120 mm	120 mm	120 mm	120 mm
Usable height of draft shield	236 mm	236 mm	236 mm	236 mm
Balance weight	5.8 kg	5.6 kg	5.8 kg	5.6 kg
Weights for routine testing				
Weights (OIML class)	100 g (F2) / 5 g (F2)	100 g (F2) / 5 g (F2)	200 g (F2) / 10 g (F2)	200 g (F2) / 10 g (F2)
Weights (ASTM class)	100 g (ASTM 1) / 5 g (ASTM 1)	100 g (ASTM 1) / 5 g (ASTM 1)	200 g (ASTM 1) / 10 g (ASTM 1)	200 g (ASTM 1) / 10 g (ASTM 1)

▲ after adjustment with internal weight

▼ determined at 5% load, k = 2

	MA303	MA303E	MA503	MA503E
Limit values				
Capacity	320 g	320 g	520 g	520 g
Nominal load	300 g	300 g	500 g	500 g
Readability	1 mg	1 mg	1 mg	1 mg
Repeatability (at 5% load)	1 mg	1 mg	1 mg	1 mg
Linearity deviation	2 mg	2 mg	2 mg	2 mg
Eccentricity deviation (at test load)	4 mg (100 g)	4 mg (100 g)	4 mg (200 g)	4 mg (200 g)
Sensitivity offset (at nominal load) ▲	8 mg	8 mg	8 mg	8 mg
Sensitivity temperature drift	0.0003%/°C	0.0003%/°C	0.0003%/°C	0.0003%/°C
Typical values				
Repeatability (at 5% load)	0.7 mg	0.7 mg	0.7 mg	0.7 mg
Linearity deviation	0.6 mg	0.6 mg	0.6 mg	0.6 mg
Eccentricity deviation (at test load)	1.2 mg (100 g)	1.2 mg (100 g)	1.2 mg (200 g)	1.2 mg (200 g)
Sensitivity offset (at nominal load) ▲	5 mg	–	5 mg	–
Minimum weight (USP, tolerance = 0.10%) ▼	1.4 g	1.4 g	1.4 g	1.4 g
Minimum weight (tolerance = 1%) ▼	140 mg	140 mg	140 mg	140 mg
Settling time	1.5 s	1.5 s	1.5 s	1.5 s
Dimensions and other specifications				
Balance dimensions (W × D × H)	209 × 354 × 354 mm	209 × 354 × 354 mm	209 × 354 × 354 mm	209 × 354 × 354 mm
Weighing pan diameter	120 mm	120 mm	120 mm	120 mm
Usable height of draft shield	236 mm	236 mm	236 mm	236 mm
Balance weight	5.8 kg	5.6 kg	5.8 kg	5.6 kg
Weights for routine testing				
Weights (OIML class)	200 g (F2) / 10 g (F2)	200 g (F2) / 10 g (F2)	500 g (F2) / 20 g (F2)	500 g (F2) / 20 g (F2)
Weights (ASTM class)	200 g (ASTM 1) / 10 g (ASTM 1)	200 g (ASTM 1) / 10 g (ASTM 1)	500 g (ASTM 1) / 20 g (ASTM 1)	500 g (ASTM 1) / 20 g (ASTM 1)

▲ after adjustment with internal weight

▼ determined at 5% load, k = 2

9.3.3 Precision balances, readability 0.01 g or 0.1 g

	MA602	MA602E	MA1002	MA1002E
Limit values				
Capacity	620 g	620 g	1.2 kg	1.2 kg
Nominal load	600 g	600 g	1 kg	1 kg
Readability	0.01 g	0.01 g	0.01 g	0.01 g
Repeatability (at 5% load)	10 mg	10 mg	10 mg	10 mg
Linearity deviation	20 mg	20 mg	20 mg	20 mg
Eccentricity deviation (at test load)	30 mg (200 g)	30 mg (200 g)	30 mg (500 g)	30 mg (500 g)
Sensitivity offset (at nominal load) ▲	40 mg	40 mg	60 mg	60 mg
Sensitivity temperature drift	0.0003%/°C	0.0003%/°C	0.0003%/°C	0.0003%/°C
Typical values				
Repeatability (at 5% load)	7 mg	7 mg	7 mg	7 mg
Linearity deviation	6 mg	6 mg	6 mg	6 mg
Eccentricity deviation (at test load)	10 mg (200 g)	10 mg (200 g)	10 mg (500 g)	10 mg (500 g)
Sensitivity offset (at nominal load) ▲	25 mg	–	40 mg	–
Minimum weight (USP, tolerance = 0.10%) ▼	14 g	14 g	14 g	14 g
Minimum weight (tolerance = 1%) ▼	1.4 g	1.4 g	1.4 g	1.4 g
Settling time	1 s	1 s	1 s	1 s
Dimensions and other specifications				
Balance dimensions (W × D × H)	209 × 354 × 100 mm	209 × 354 × 100 mm	209 × 354 × 100 mm	209 × 354 × 100 mm
Weighing pan dimensions (W × D)	180 × 180 mm	180 × 180 mm	180 × 180 mm	180 × 180 mm
Balance weight	4.1 kg	3.9 kg	4.1 kg	3.9 kg
Weights for routine testing				
Weights (OIML class)	500 g (F2) / 20 g (F2)	500 g (F2) / 20 g (F2)	1 kg (F2) / 50 g (F2)	1 kg (F2) / 50 g (F2)
Weights (ASTM class)	500 g (ASTM 1) / 20 g (ASTM 1)	500 g (ASTM 1) / 20 g (ASTM 1)	1 kg (ASTM 1) / 50 g (ASTM 1)	1 kg (ASTM 1) / 50 g (ASTM 1)

▲ after adjustment with internal weight

▼ determined at 5% load, k = 2

	MA2002	MA2002E	MA3002	MA3002E
Limit values				
Capacity	2.2 kg	2.2 kg	3.2 kg	3.2 kg
Nominal load	2 kg	2 kg	3 kg	3 kg
Readability	0.01 g	0.01 g	0.01 g	0.01 g
Repeatability (at 5% load)	10 mg	10 mg	10 mg	10 mg
Linearity deviation	20 mg	20 mg	20 mg	20 mg
Eccentricity deviation (at test load)	30 mg (1 kg)	30 mg (1 kg)	40 mg (1 kg)	40 mg (1 kg)
Sensitivity offset (at nominal load) ▲	80 mg	80 mg	80 mg	80 mg
Sensitivity temperature drift	0.0003%/°C	0.0003%/°C	0.0003%/°C	0.0003%/°C
Typical values				
Repeatability (at 5% load)	7 mg	7 mg	7 mg	7 mg
Linearity deviation	6 mg	6 mg	6 mg	6 mg
Eccentricity deviation (at test load)	10 mg (1 kg)	10 mg (1 kg)	12 mg (1 kg)	12 mg (1 kg)
Sensitivity offset (at nominal load) ▲	50 mg	–	50 mg	–
Minimum weight (USP, tolerance = 0.10%) ▼	14 g	14 g	14 g	14 g
Minimum weight (tolerance = 1%) ▼	1.4 g	1.4 g	1.4 g	1.4 g
Settling time	1 s	1 s	1 s	1 s
Dimensions and other specifications				
Balance dimensions (W × D × H)	209 × 354 × 100 mm	209 × 354 × 100 mm	209 × 354 × 100 mm	209 × 354 × 100 mm
Weighing pan dimensions (W × D)	180 × 180 mm	180 × 180 mm	180 × 180 mm	180 × 180 mm
Balance weight	4.1 kg	3.9 kg	4.1 kg	3.9 kg
Weights for routine testing				
Weights (OIML class)	2000 g (F2) / 100 g (F2)	2000 g (F2) / 100 g (F2)	2 kg (F2) / 100 g (F2)	2 kg (F2) / 100 g (F2)
Weights (ASTM class)	2000 g (ASTM 1) / 100 g (ASTM 1)	2000 g (ASTM 1) / 100 g (ASTM 1)	2 kg (ASTM 1) / 100 g (ASTM 1)	2 kg (ASTM 1) / 100 g (ASTM 1)

▲ after adjustment with internal weight

▼ determined at 5% load, k = 2

	MA4002	MA4002E	MA6002	MA6002E
Limit values				
Capacity	4.2 kg	4.2 kg	6.2 kg	6.2 kg
Nominal load	4 kg	4 kg	6 kg	6 kg
Readability	0.01 g	0.01 g	0.01 g	0.01 g
Repeatability (at 5% load)	10 mg	10 mg	10 mg	10 mg
Linearity deviation	20 mg	20 mg	20 mg	20 mg
Eccentricity deviation (at test load)	40 mg (2 kg)	40 mg (2 kg)	40 mg (2 kg)	40 mg (2 kg)
Sensitivity offset (at nominal load) ▲	80 mg	80 mg	80 mg	80 mg
Sensitivity temperature drift	0.0003%/°C	0.0003%/°C	0.0003%/°C	0.0003%/°C
Typical values				
Repeatability (at 5% load)	7 mg	7 mg	7 mg	7 mg
Linearity deviation	6 mg	6 mg	6 mg	6 mg
Eccentricity deviation (at test load)	12 mg (2 kg)	12 mg (2 kg)	12 mg (2 kg)	12 mg (2 kg)
Sensitivity offset (at nominal load) ▲	50 mg	–	50 mg	–
Minimum weight (USP, tolerance = 0.10%) ▼	14 g	14 g	14 g	14 g
Minimum weight (tolerance = 1%) ▼	1.4 g	1.4 g	1.4 g	1.4 g
Settling time	1 s	1 s	1 s	1 s
Dimensions and other specifications				
Balance dimensions (W × D × H)	209 × 354 × 100 mm	209 × 354 × 100 mm	209 × 354 × 100 mm	209 × 354 × 100 mm
Weighing pan dimensions (W × D)	180 × 180 mm	180 × 180 mm	180 × 180 mm	180 × 180 mm
Balance weight	4.1 kg	3.9 kg	4.1 kg	3.9 kg
Weights for routine testing				
Weights (OIML class)	2 kg (F2) / 200 g (F2)	2 kg (F2) / 200 g (F2)	5 kg (F2) / 200 g (F2)	5 kg (F2) / 200 g (F2)
Weights (ASTM class)	2 kg (ASTM 1) / 200 g (ASTM 1)	2 kg (ASTM 1) / 200 g (ASTM 1)	5 kg (ASTM 4) / 200 g (ASTM 4)	5 kg (ASTM 4) / 200 g (ASTM 4)

▲ after adjustment with internal weight

▼ determined at 5% load, k = 2

	MA5001	MA5001E
Limit values		
Capacity	5.2 kg	5.2 kg
Nominal load	5 kg	5 kg
Readability	0.1 g	0.1 g
Repeatability (at 5% load)	80 mg	80 mg
Linearity deviation	60 mg	60 mg
Eccentricity deviation (at test load)	300 mg (2 kg)	300 mg (2 kg)
Sensitivity offset (at nominal load) ▲	240 mg	240 mg
Sensitivity temperature drift	0.0015%/°C	0.0015%/°C
Typical values		
Repeatability (at 5% load)	50 mg	50 mg
Linearity deviation	20 mg	20 mg
Eccentricity deviation (at test load)	100 mg (2 kg)	100 mg (2 kg)
Sensitivity offset (at nominal load) ▲	150 mg	–
Minimum weight (USP, tolerance = 0.10%) ▼	100 g	100 g
Minimum weight (tolerance = 1%) ▼	10 g	10 g
Settling time	1 s	1 s
Dimensions and other specifications		
Balance dimensions (W × D × H)	209 × 354 × 100 mm	209 × 354 × 100 mm
Weighing pan dimensions (W × D)	180 × 180 mm	180 × 180 mm
Balance weight	4.1 kg	3.9 kg
Weights for routine testing		
Weights (OIML class)	5 kg (F2) / 200 g (F2)	5 kg (F2) / 200 g (F2)
Weights (ASTM class)	5 kg (ASTM 4) / 200 g (ASTM 4)	5 kg (ASTM 4) / 200 g (ASTM 4)

▲ after adjustment with internal weight

▼ determined at 5% load, k = 2

9.3.4 Precision balances, large

	MA12001L	MA16001L	MA32001L	MA32000L
Limit values				
Capacity	12.2 kg	16.2 kg	32.2 kg	32.2 kg
Nominal load	12 kg	16 kg	30 kg	30 kg
Readability	0.1 g	0.1 g	0.1 g	1 g
Repeatability (at 5% load)	80 mg	80 mg	80 mg	600 mg
Linearity deviation	200 mg	200 mg	250 mg	300 mg
Eccentricity deviation (at test load)	300 mg (5 kg)	300 mg (5 kg)	300 mg (10 kg)	1 g (10 kg)
Sensitivity offset (at nominal load) ▲	600 mg	800 mg	900 mg	1 g
Sensitivity temperature drift	0.0015%/°C	0.0015%/°C	0.0015%/°C	0.0015%/°C
Typical values				
Repeatability (at 5% load)	40 mg	40 mg	40 mg	400 mg
Linearity deviation	60 mg	60 mg	80 mg	100 mg
Eccentricity deviation (at test load)	100 mg (5 kg)	100 mg (5 kg)	100 mg (10 kg)	300 mg (10 kg)
Sensitivity offset (at nominal load) ▲	400 mg	500 mg	550 mg	650 mg
Minimum weight (USP, tolerance = 0.10%) ▼	82 g	82 g	82 g	820 g
Minimum weight (tolerance = 1%) ▼	8.2 g	8.2 g	8.2 g	82 g
Settling time	1.5 s	1.5 s	1.5 s	1.2 s
Dimensions and other specifications				
Balance dimensions (W × D × H)	354 × 380 × 126 mm	354 × 380 × 126 mm	354 × 380 × 126 mm	354 × 380 × 126 mm
Weighing pan dimensions (W × D)	352 × 246 mm	352 × 246 mm	352 × 246 mm	352 × 246 mm
Balance weight	11.3 kg	11.3 kg	11.3 kg	11.3 kg
Weights for routine testing				
Weights (OIML class)	10 kg (F2) / 500 g (F2)	10 kg (F2) / 500 g (F2)	20 kg (F2) / 1 kg (F2)	20 kg (F2) / 1 kg (F2)
Weights (ASTM class)	10 kg (ASTM 4) / 500 g (ASTM 4)	10 kg (ASTM 4) / 500 g (ASTM 4)	20 kg (ASTM 4) / 1 kg (ASTM 4)	20 kg (ASTM 4) / 1 kg (ASTM 4)

▲ after adjustment with internal weight

▼ determined at 5% load, k = 2

9.3.5 Precision balances, compact

	MA602P	MA602PE	MA2002P	MA2002PE
Limit values				
Capacity	620 g	620 g	2.2 kg	2.2 kg
Nominal load	600 g	600 g	2 kg	2 kg
Readability	0.01 g	0.01 g	0.01 g	0.01 g
Repeatability (at 5% load)	10 mg	10 mg	10 mg	10 mg
Linearity deviation	20 mg	20 mg	20 mg	20 mg
Eccentricity deviation (at test load)	0.03 g (200 g)	30 mg (200 g)	30 mg (1 kg)	30 mg (1 kg)
Sensitivity offset (at nominal load) ▲	40 mg	40 mg	80 mg	80 mg
Sensitivity temperature drift	0.001%/°C	0.001%/°C	0.001%/°C	0.001%/°C
Typical values				
Repeatability (at 5% load)	7 mg	7 mg	7 mg	7 mg
Linearity deviation	6 mg	6 mg	6 mg	6 mg
Eccentricity deviation (at test load)	10 mg (200 g)	10 mg (200 g)	10 mg (1 kg)	10 mg (1 kg)
Sensitivity offset (at nominal load) ▲	25 mg	–	50 mg	–
Minimum weight (USP, tolerance = 0.10%) ▼	14 g	14 g	14 g	14 g
Minimum weight (tolerance = 1%) ▼	1.4 g	1.4 g	1.4 g	1.4 g
Settling time	1.5 s	1.5 s	1.5 s	1.5 s
Dimensions and other specifications				
Balance dimensions (W × D × H)	177 × 253 × 74 mm	177 × 253 × 74 mm	177 × 253 × 74 mm	177 × 253 × 74 mm
Weighing pan dimensions (W × D)	160 × 160 mm	160 × 160 mm	160 × 160 mm	160 × 160 mm
Balance weight	1.8 kg	1.6 kg	1.8 kg	1.6 kg
Weights for routine testing				
Weights (OIML class)	500 g (F2) / 20 g (F2)	500 g (F2) / 20 g (F2)	2 kg (F2) / 100 g (F2)	2 kg (F2) / 100 g (F2)
Weights (ASTM class)	500 g (ASTM 1) / 20 g (ASTM 1)	500 g (ASTM 1) / 20 g (ASTM 1)	2 kg (ASTM 1) / 100 g (ASTM 1)	2 kg (ASTM 1) / 100 g (ASTM 1)

▲ after adjustment with internal weight

▼ determined at 5% load, k = 2

	MA6001P	MA6001PE
Limit values		
Capacity	6.2 kg	6.2 kg
Nominal load	6 kg	6 kg
Readability	0.1 g	0.1 g
Repeatability (at 5% load)	100 mg	100 mg
Linearity deviation	200 mg	200 mg
Eccentricity deviation (at test load)	300 mg (2 kg)	300 mg (2 kg)
Sensitivity offset (at nominal load) ▲	400 mg	400 mg
Sensitivity temperature drift	0.0015%/°C	0.0015%/°C
Typical values		
Repeatability (at 5% load)	70 mg	70 mg
Linearity deviation	60 mg	60 mg
Eccentricity deviation (at test load)	100 mg (2 kg)	100 mg (2 kg)
Sensitivity offset (at nominal load) ▲	250 mg	–
Minimum weight (USP, tolerance = 0.10%) ▼	140 g	140 g
Minimum weight (tolerance = 1%) ▼	14 g	14 g
Settling time	1 s	1 s
Dimensions and other specifications		
Balance dimensions (W × D × H)	177 × 253 × 74 mm	177 × 253 × 74 mm
Weighing pan dimensions (W × D)	160 × 160 mm	160 × 160 mm
Balance weight	1.8 kg	1.6 kg
Weights for routine testing		
Weights (OIML class)	5 kg (F2) / 200 g (F2)	5 kg (F2) / 200 g (F2)
Weights (ASTM class)	5 kg (ASTM 4) / 200 g (ASTM 4)	5 kg (ASTM 4) / 200 g (ASTM 4)

▲ after adjustment with internal weight

▼ determined at 5% load, k = 2

9.4 Dimensions

Dimensions in mm.

9.4.1 MA analytical balances, readability 0.01 mg

Balance models: MA55, MA95, MA155DU

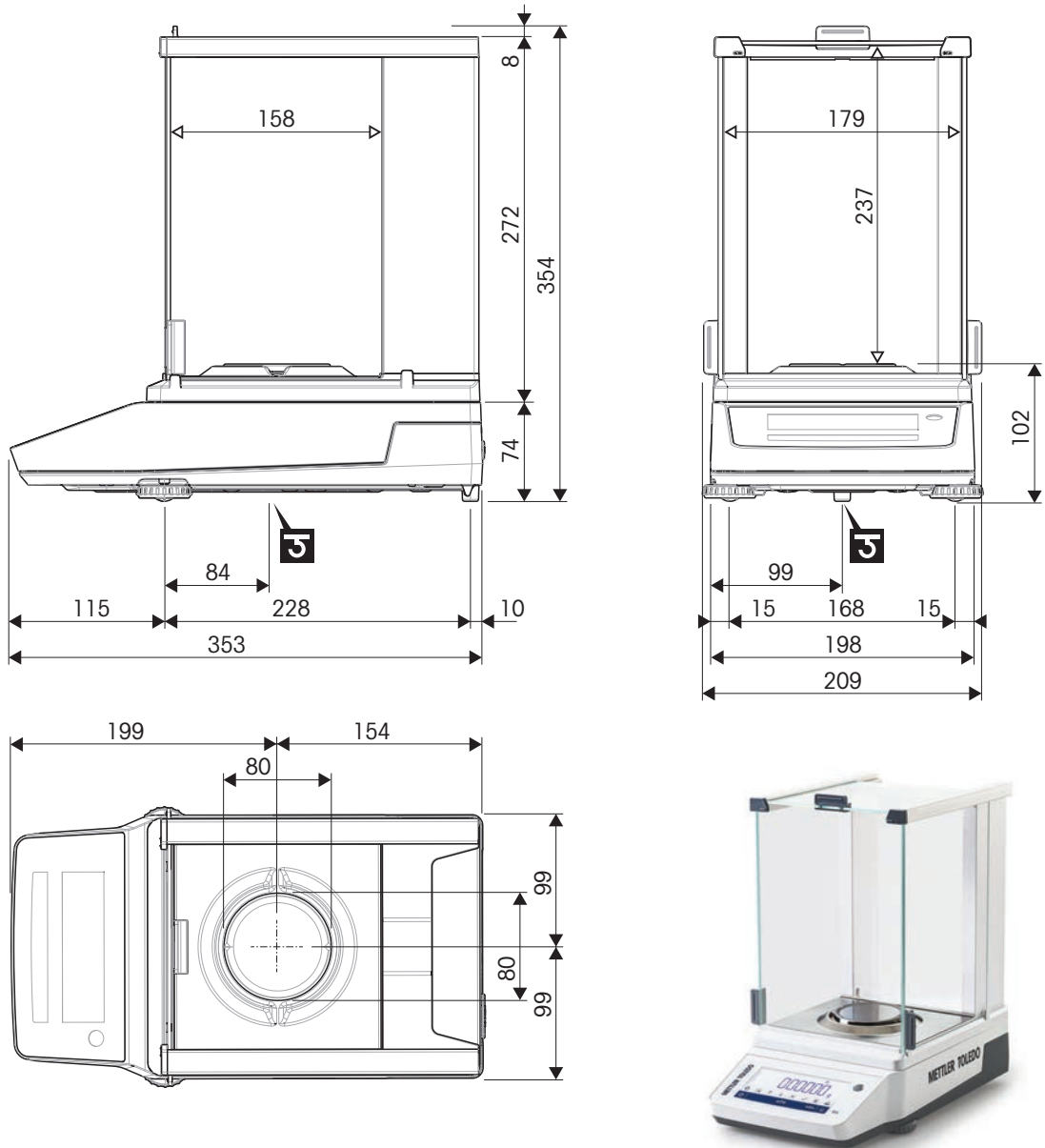

	Outer dimensions [mm]
	Clear dimensions [mm]
	Position of the weighing hook axle

9.4.2 MA analytical balances, readability 0.1 mg

Balance models: MA54, MA54E, MA104, MA104E, MA204, MA204E

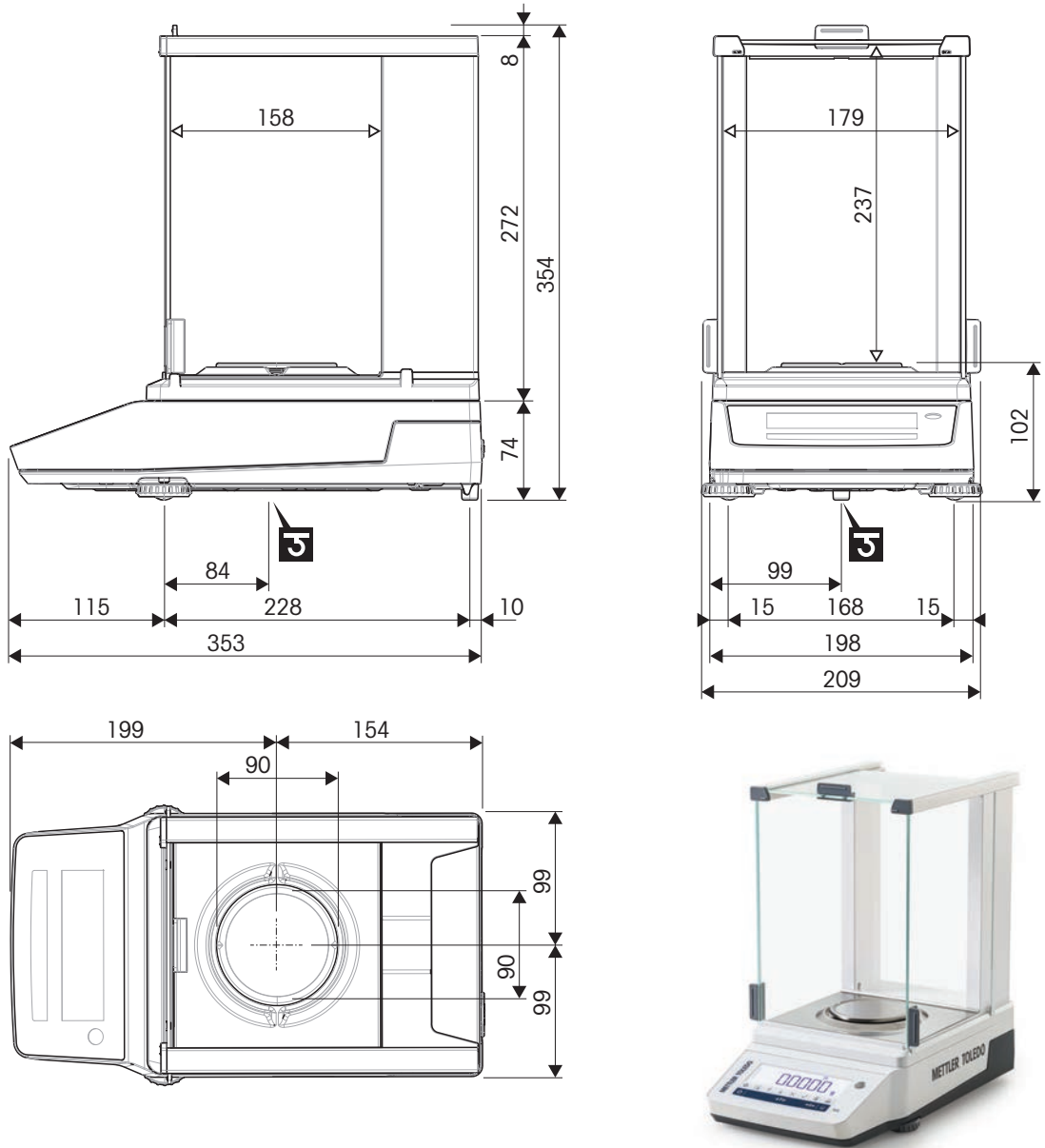

	Outer dimensions [mm]
	Clear dimensions [mm]
	Position of the weighing hook axle

9.4.3 MA precision balances, small, readability 1 mg

Balance models: MA103, MA103E, MA203, MA203E, MA303, MA303E, MA503, MA503E

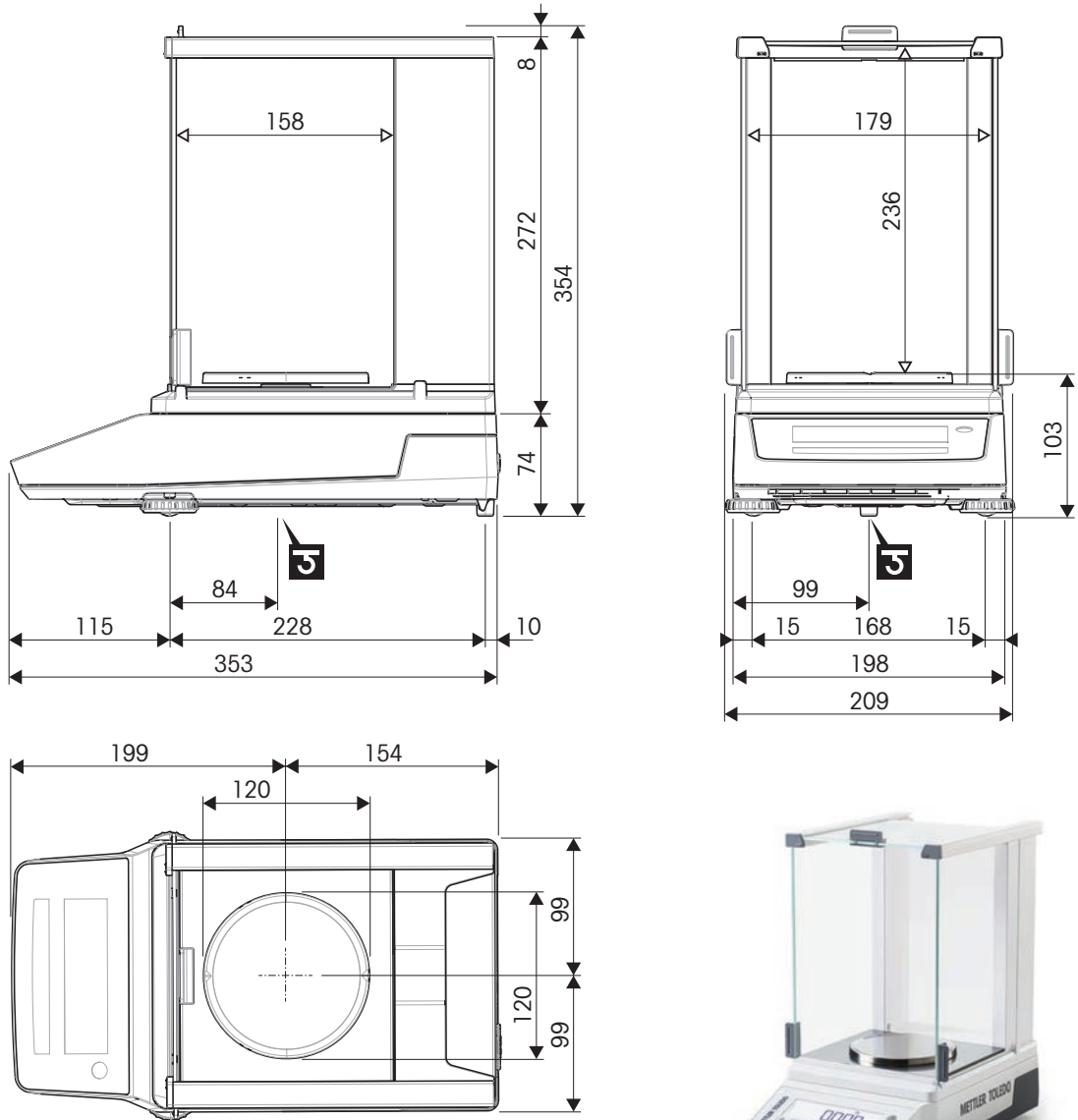

↔	Outer dimensions [mm]
◁ ▷	Clear dimensions [mm]
J	Position of the weighing hook axle

9.4.4 MA precision balances, small, readability 0.01 g / 0.1 g

Balances models: MA602, MA602E, MA1002, MA1002E, MA2002, MA2002E, MA3002, MA3002E, MA4002, MA4002E, MA6002, MA6002E, MA5001, MA5001E

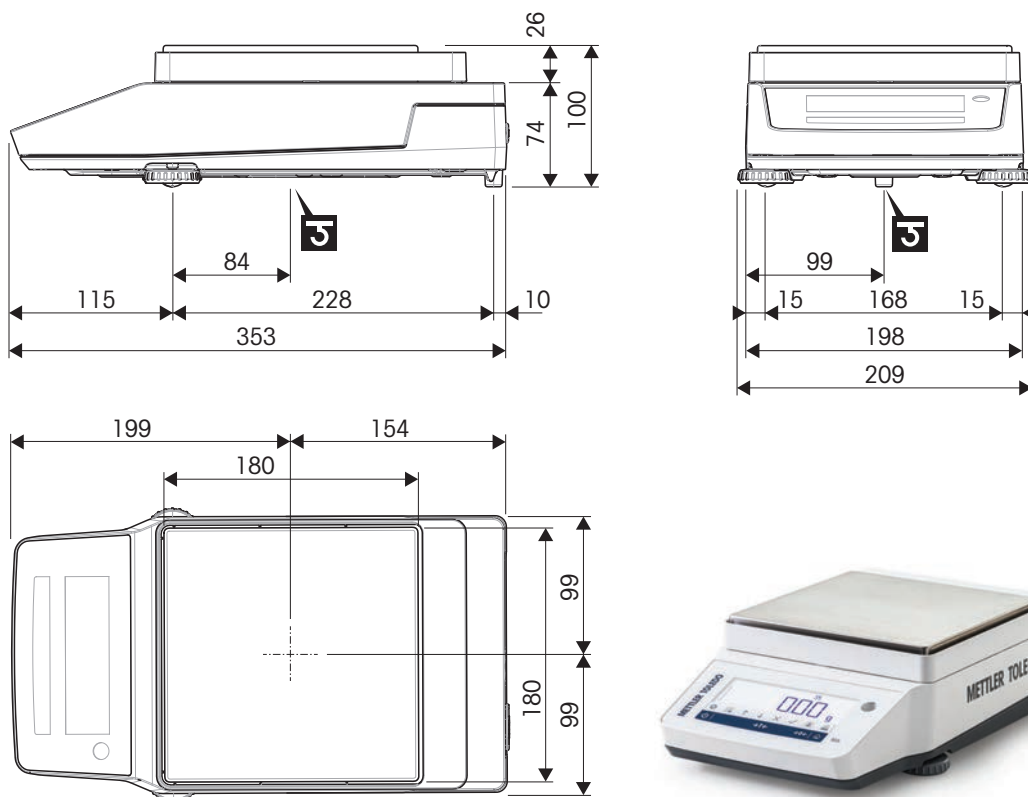

↔	Outer dimensions [mm]
◁ →	Clear dimensions [mm]
5	Position of the weighing hook axle

9.4.5 MA precision balances, large, readability 0.1 g / 1 g

Balance models: MA12001L, MA16001L, MA32001L, MA32000L

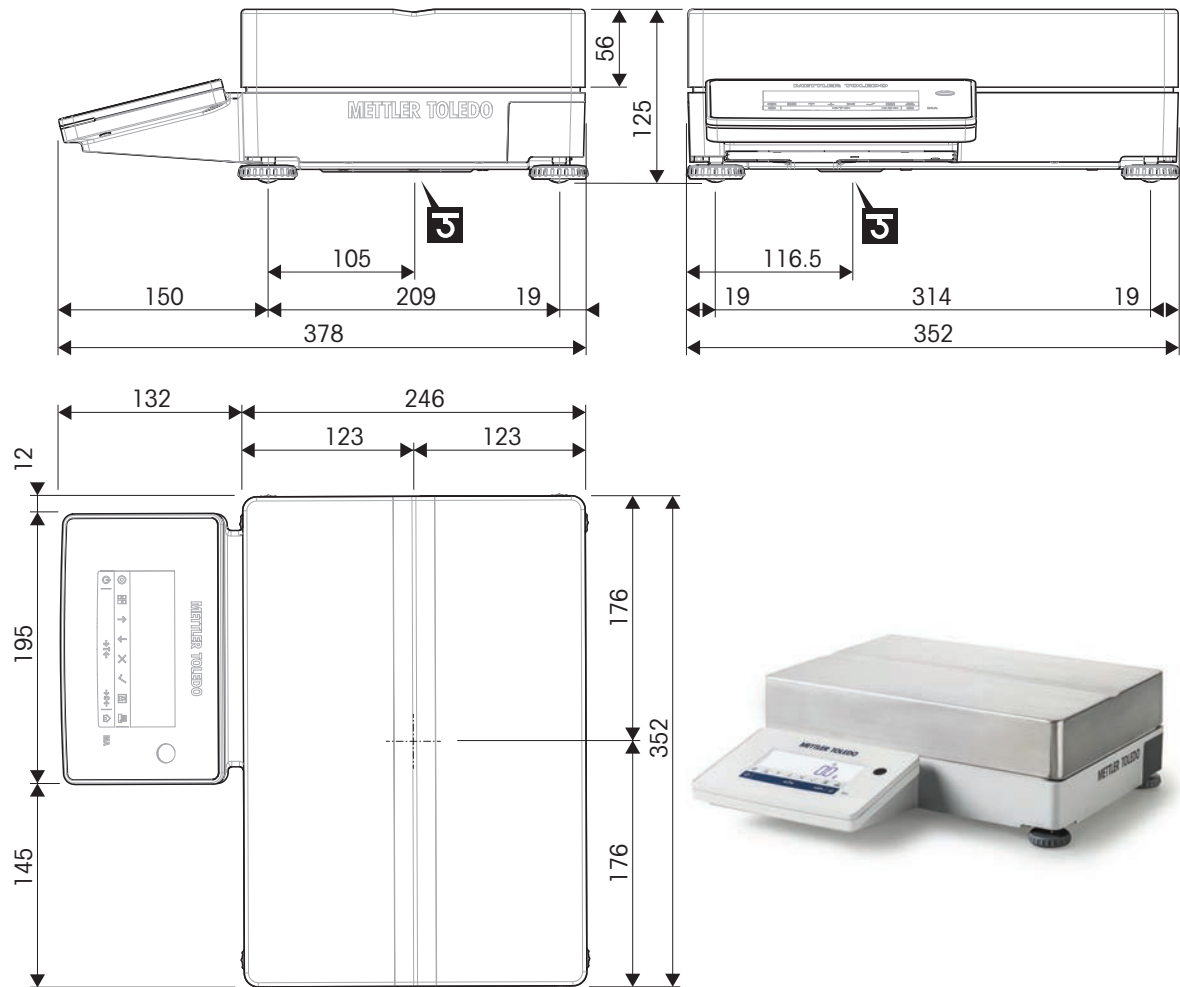

	Outer dimensions [mm]
	Clear dimensions [mm]
	Position of the weighing hook axle

9.4.6 MA precision balances, compact, readability 0.01 g / 0.1 g

Balance models: MA602P, MA602PE, MA2002P, MA2002PE, MA6001P, MA6001PE

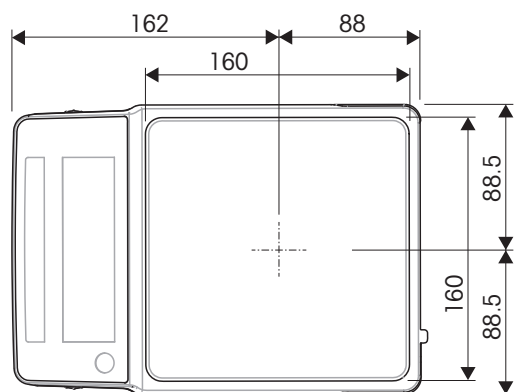
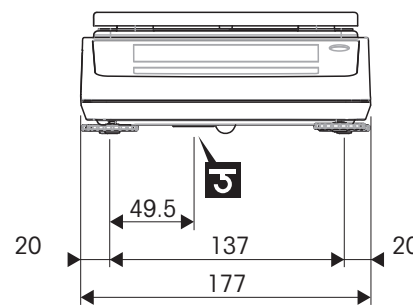
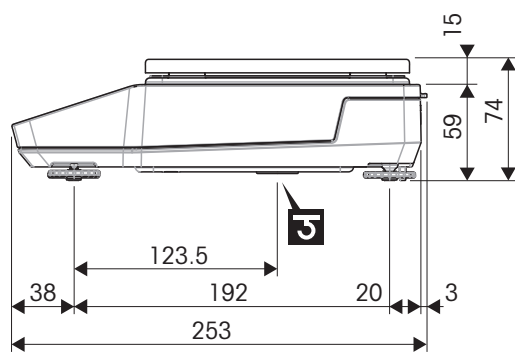

	Outer dimensions [mm]
	Clear dimensions [mm]
	Position of the weighing hook axle

10 Accessories and Spare Parts

10.1 Accessories

Accessories are additional components that could help you in your workflow.

Antistatic kits



Ionizer ASK350

30893023

- Removes small electrostatic charges from weighing samples and tare containers

Density determination



Density kit

30706714

- Gravimetric density determination of solids



Thermometer, calibrated

11132685

- Including: holder, calibration certificate
- For usage in density determination

Auxiliary displays



Auxiliary display AD-RS-M7

12122381

- Duplicates the information of the balance display
- Interface: RS232

Printers



Printer RS-P25

30702967

- Printing technology: dot matrix



Printer USB-P25**30702998**

- Printing technology: dot matrix



Printer P-52RUE**30237290**

- Printing technology: dot matrix



Printing paper roll, self-adhesive, dot matrix**11600388**

- Set of 3 rolls
- Compatible with: dot matrix printers



Printing paper roll, standard, dot matrix**72456**

- Set of 5 rolls
- Compatible with: dot matrix printers



Ribbon cartridge**65975**

- Including: 2 pcs
- Compatible with: dot matrix printers

Anti-theft devices

Anti-theft cable**11600361**

Hands-free accessories

Foot switch**30312558**

- Hands-free taring, zeroing, printing
-

Cables



Cable RS232 (f) – USB-A (m)

30576241

- Data transfer between balance and peripheral
- Length: 1.7 m



Cable RS232 (m) – USB-A (m)

64088427

- Data transfer between balance and peripheral
- Length: 2 m



Cable RS9 (m) – RS9 (f)

11101051

- Data transfer between instrument and peripheral
- Length: 1 m

Wireless interfaces



Bluetooth adapter ADP-BT-S, single

30086494

- Creates a bluetooth connection between instrument and peripheral



Bluetooth adapter ADP-BT-P, set

30086495

- Creates a bluetooth connection between instrument and peripheral

Software



EasyDirect Balance

EasyDirect Balance, 10 licenses

30540473

- Data management software for up to 10 balances
- Collection, analysis, storage and export of weighing data



EasyDirect Balance

EasyDirect Balance, 3 licenses

30539323

- Data management software for up to 3 balances
- Collection, analysis, storage and export of weighing data

Adjustment weights



Weights

- For routine testing and calibration of weighing instruments
- Available in different accuracy classes
- With calibration certificate (OIML/ASTM)

► www.mt.com/weights

Dust covers for compact balances



Dust cover

30893020

Draft shields for precision balances with readability of 0.01 g

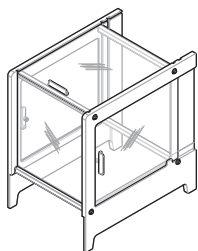

External draft shield

30706715

- Protects against air currents and dust to maintain measurement accuracy
- Doors: glass; frame: acrylic, aluminium

Various



SmartPrep weighing funnel

30061260

- For weighing powdery substances
- Including: 50 pcs



Protective foil

30706721

- Protects the weighing pan
- Including: 10 pcs
- 177 × 177 mm



EasyHub USB

30468768

- Connects up to 4 peripherals
- Interface to host: USB-B

10.2 Spare parts

Spare parts are parts that are delivered with the original instrument but that can be replaced, if needed, without the help of a service technician.

10.2.1 MA analytical balances, readability 0.01 mg

Balance models: MA55, MA95, MA155DU

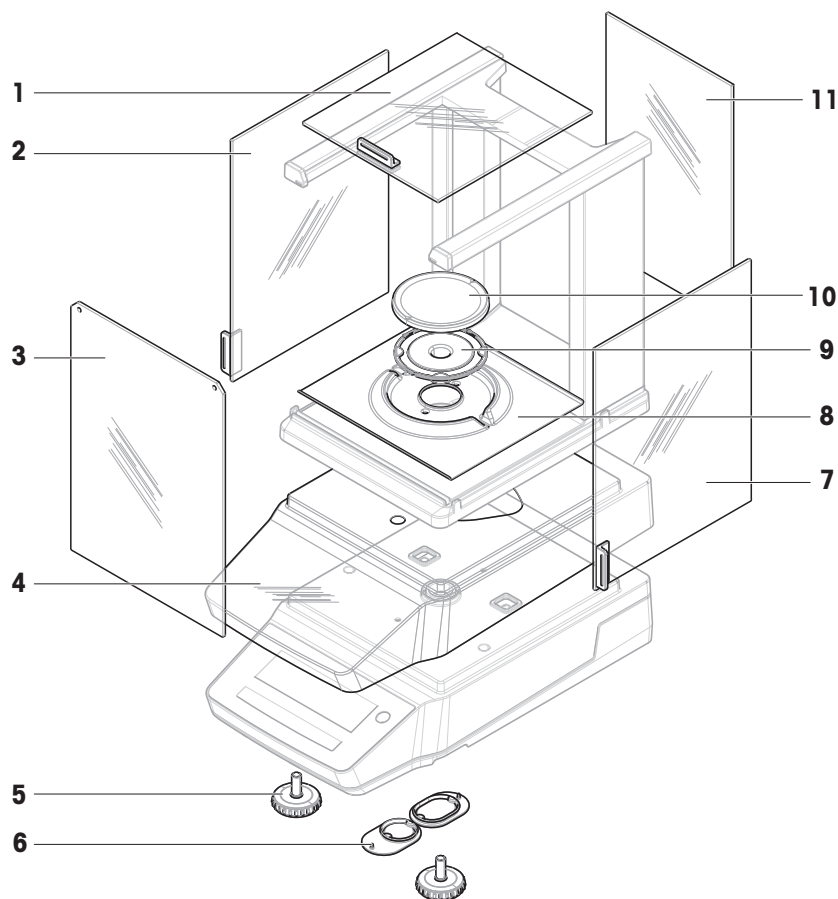

	Order no.	Designation	Remarks
1	30706623	Door, top	Material: glass; including: door handle
2	30706624	Door, left	Material: glass; including: door handle
3	30706626	Panel, front	Material: glass
4	30706657	Protective cover	–
5	30706696	Leveling foot	Including: 2 pcs
6	30706724	Cover, weighing hook	Including: 1 round cover, 1 oval cover; material: silicone
7	30706625	Door, right	Material: glass; including: door handle
8	30893025	Draft-protection element	For weighing pan \varnothing 80 mm
9	30893028	Pan support \varnothing 80 mm	–
10	30893027	Weighing pan \varnothing 80 mm	Excluding: Pan support
11	30706627	Panel, back	Material: glass

10.2.2 MA analytical balances, readability 0.1 mg

Balance models: MA54, MA54E, MA104, MA104E, MA204, MA204E

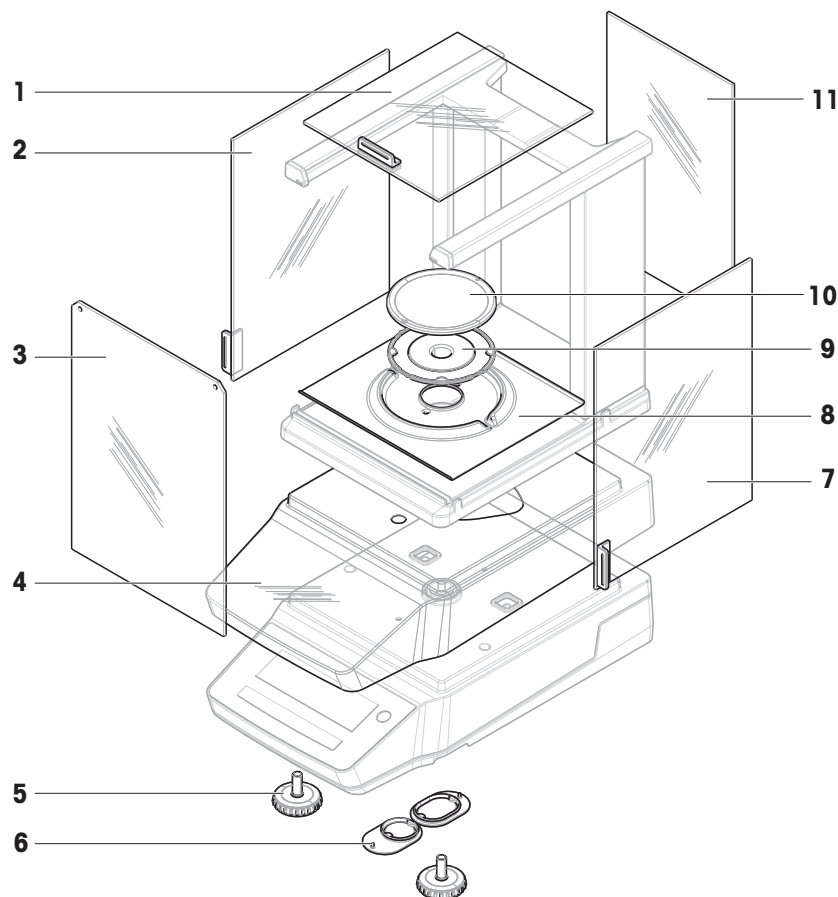

	Order no.	Designation	Remarks
1	30706623	Door, top	Material: glass; including: door handle
2	30706624	Door, left	Material: glass; including: door handle
3	30706626	Panel, front	Material: glass
4	30706657	Protective cover	–
5	30706696	Leveling foot	Including: 2 pcs
6	30706724	Cover, weighing hook	Including: 1 round cover, 1 oval cover; material: silicone
7	30706625	Door, right	Material: glass; including: door handle
8	30706629	Draft-protection element	For weighing pan \varnothing 90 mm
9	30706639	Pan support \varnothing 90 mm	–
10	12122010	Weighing pan \varnothing 90 mm	Excluding: Pan support
11	30706627	Panel, back	Material: glass

10.2.3 MA precision balances, small, readability 1 mg

Balance models: MA103, MA103E, MA203, MA203E, MA303, MA303E, MA503, MA503E

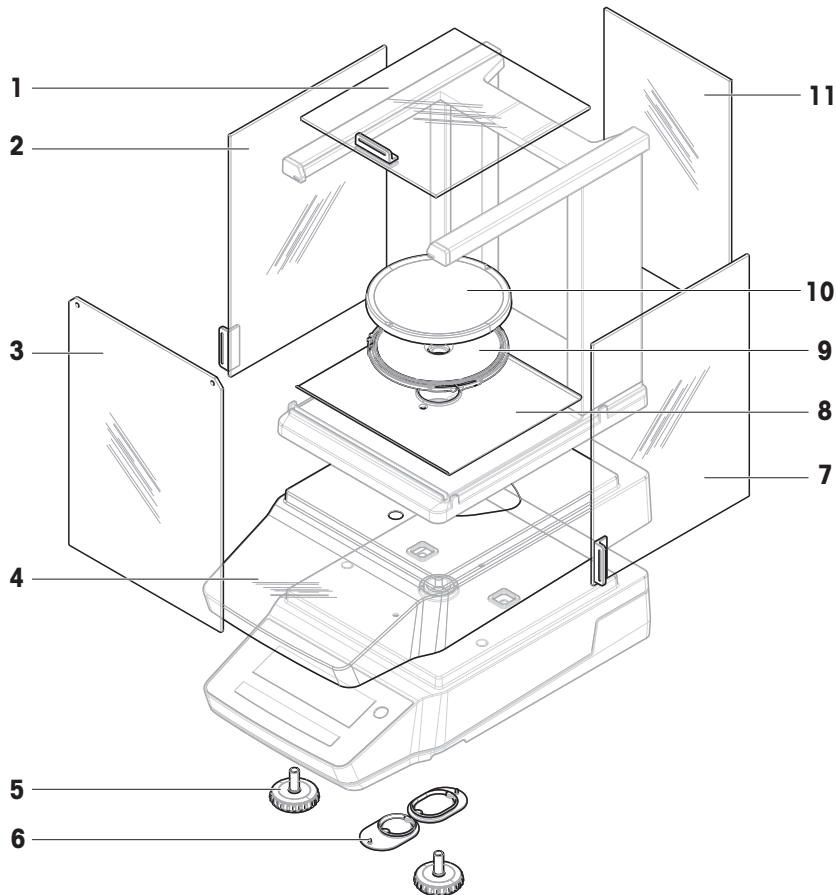

	Order no.	Designation	Remarks
1	30706623	Door, top	Material: glass; including: door handle
2	30706624	Door, left	Material: glass; including: door handle
3	30706626	Panel, front	Material: glass
4	30706657	Protective cover	–
5	30706696	Leveling foot	Including: 2 pcs
6	30706724	Cover, weighing hook	Including: 1 round cover, 1 oval cover; material: silicone
7	30706625	Door, right	Material: glass; including: door handle
8	30850022	Base plate	–
9	30706638	Pan support \varnothing 120 mm	–
10	12122037	Weighing pan \varnothing 120 mm	Excluding: pan support
11	30706627	Panel, back	Material: glass

10.2.4 MA precision balances, small, readability 0.01 g / 0.1 g

Balances models: MA602, MA602E, MA1002, MA1002E, MA2002, MA2002E, MA3002, MA3002E, MA4002, MA4002E, MA6002, MA6002E, MA5001, MA5001E

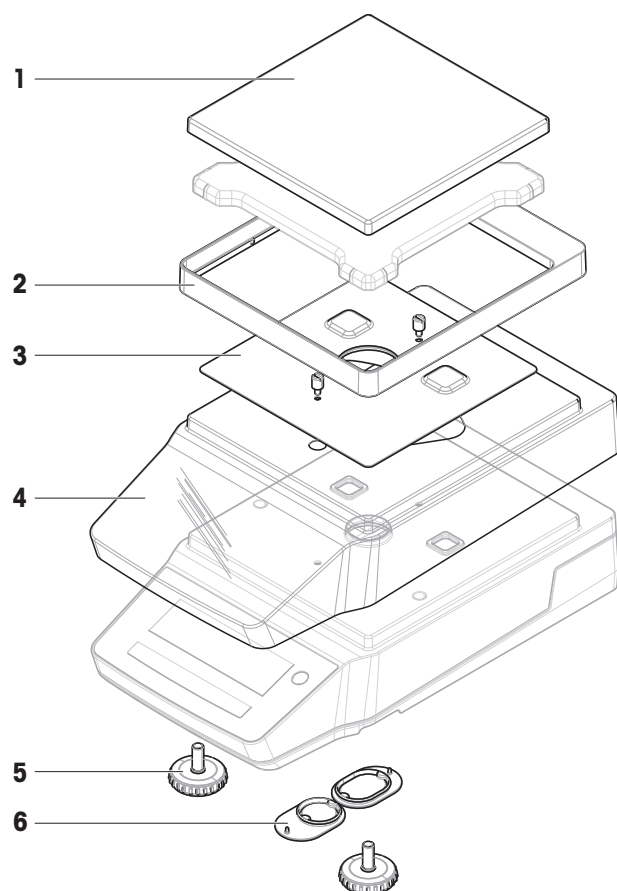

	Order no.	Designation	Remarks
1	30535713	Weighing pan 180 x 180 mm	Excluding: pan support
2	30706647	Draft protection element	–
3	30706650	EMC plate	Including: 2 screws
4	30706657	Protective cover	–
5	30706696	Leveling foot	Including: 2 pcs
6	30706724	Cover, weighing hook	Including: 1 round cover, 1 oval cover; material: silicone

10.2.5 MA precision balances, large, readability 0.1 g / 1 g

Balance models: MA12001L, MA16001L, MA32001L, MA32000L

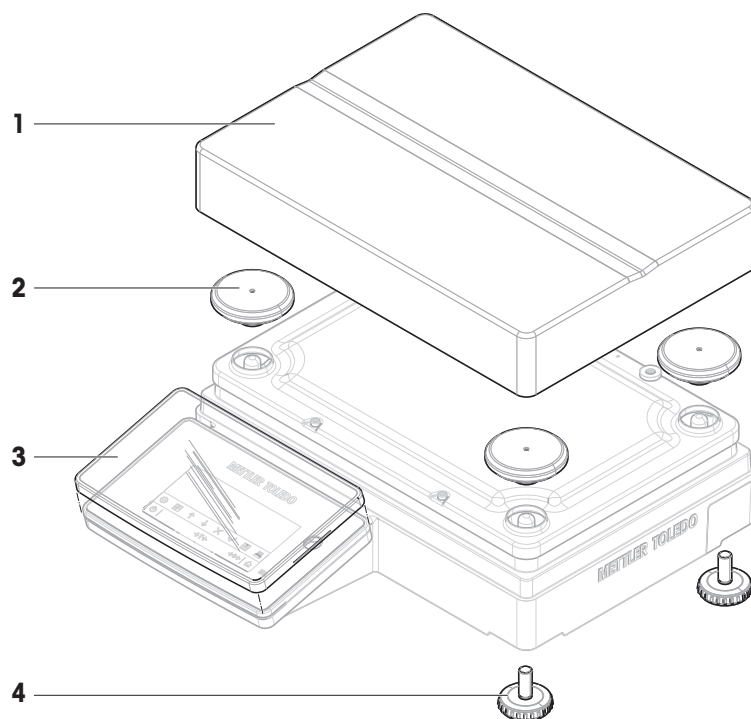

	Order no.	Designation	Remarks
1	30706734	Weighing pan	246 × 252 mm
2	30706735	Cap, pan support	Including: 4 pcs
3	30706652	Protective cover	For terminal
4	30850018	Leveling foot	Including: 4 pcs

10.2.6 MA precision balances, compact, readability 0.01 g / 0.1 g

Balance models: MA602P, MA602PE, MA2002P, MA2002PE, MA6001P, MA6001PE

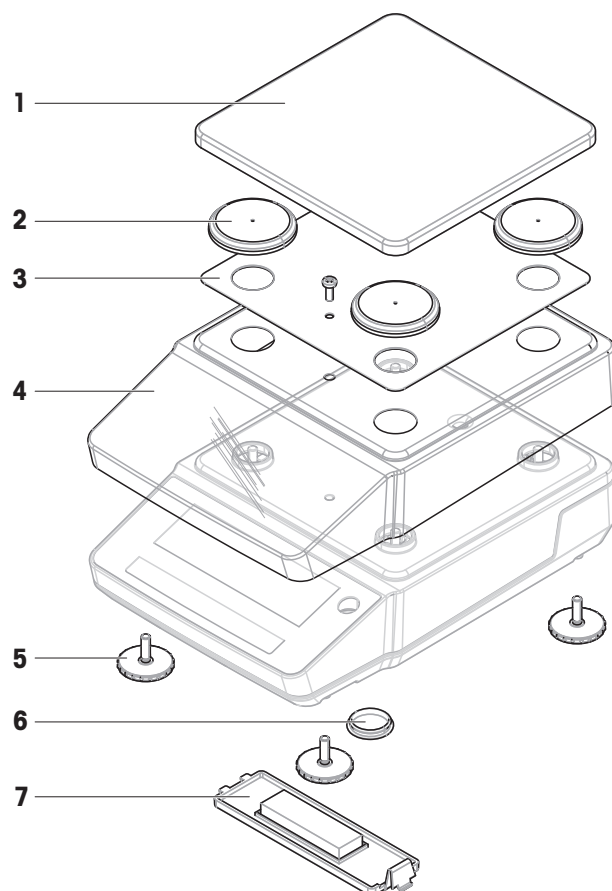

	Order no.	Designation	Remarks
1	30850025	Weighing pan	–
2	30850027	Cap, pan support	Including: 4 pcs
3	30850026	EMC plate	Including: 1 screw
4	30850029	Protective cover	–
5	30850033	Leveling foot	Including: 4 pcs
6	30850036	Cover, weighing hook	–
7	30850032	Cover, battery case	–

10.2.7 AC/DC adapter, universal

Compatible with all MA balance models.

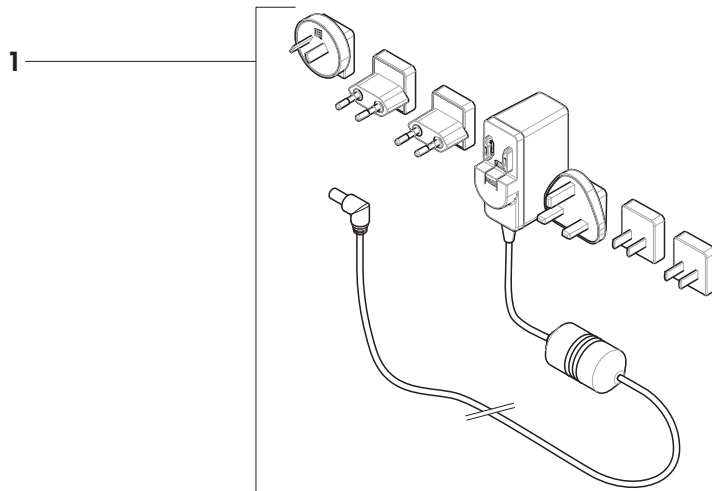

	Order no.	Designation	Remarks
1	30850040	AC/DC adapter universal	Output: 12 V, 1.0 A; including: 6 plugs (EU, UK, US, AU, CN, KR)

10.2.8 Packaging

10.2.8.1 Balances with draft shield

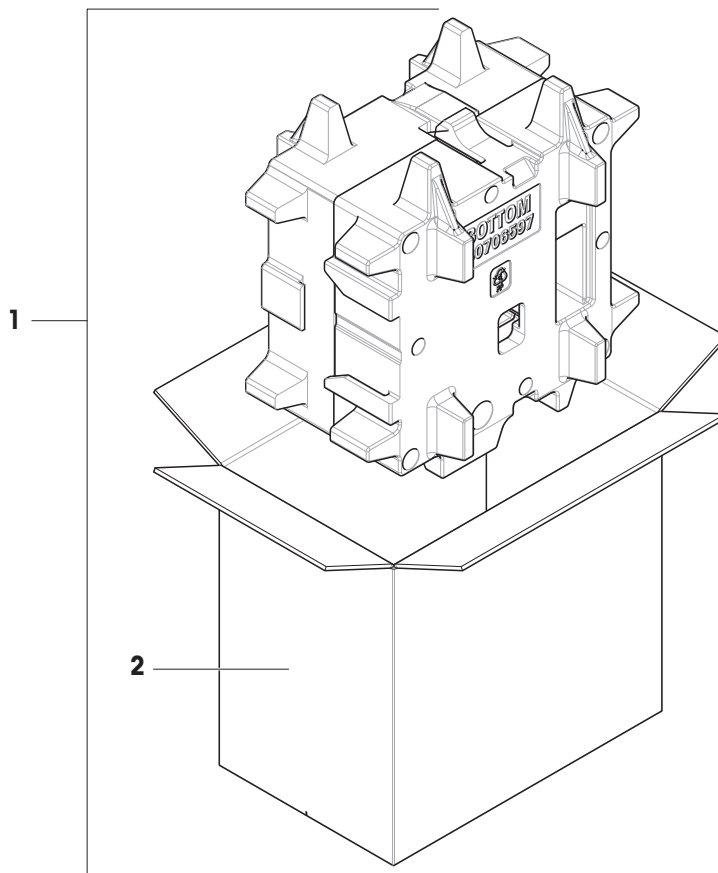

	Order no.	Designation	Remarks
1	30850023	Packaging	Including: export box, inner protection material
2	30850024	Export box	Excluding: inner protection material

10.2.8.2 Balances without draft shield

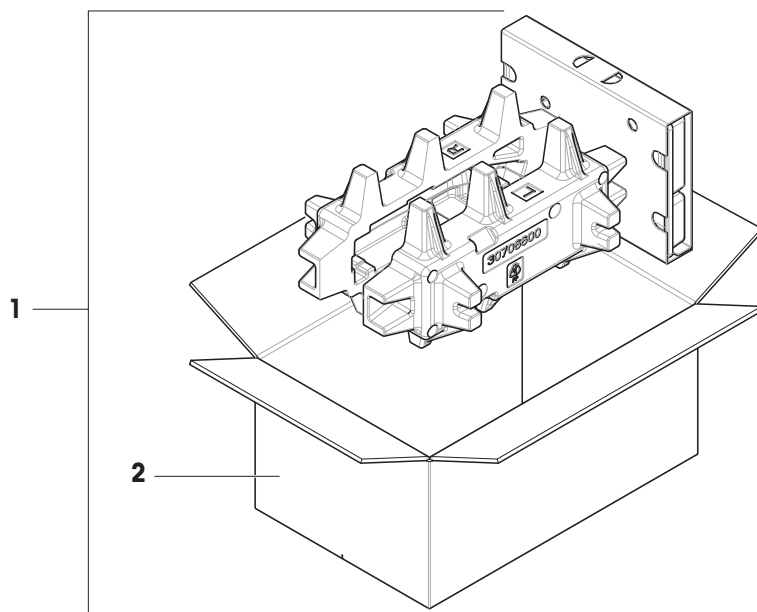

	Order no.	Designation	Remarks
1	30850037	Packaging	Including: export box, inner protection material
2	30850043	Export box	Excluding: inner protection material

10.2.8.3 Balances, large

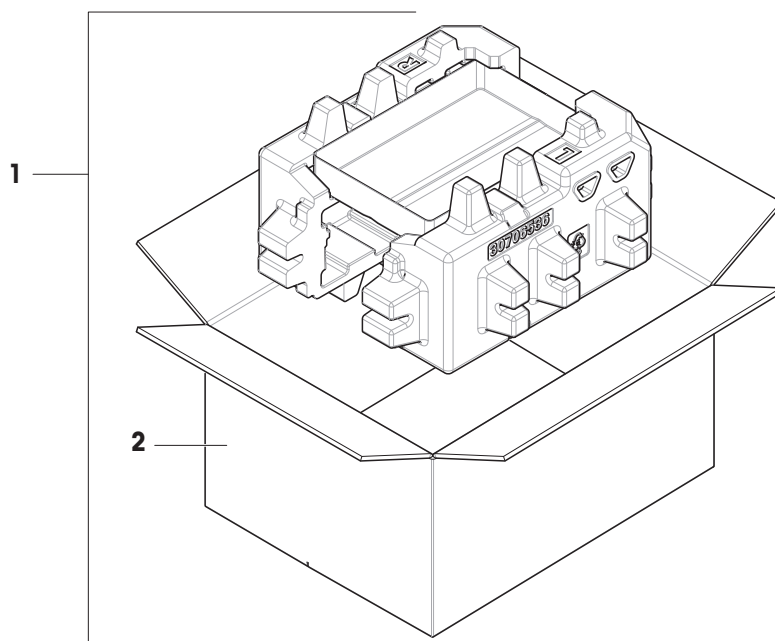

	Order no.	Designation	Remarks
1	30706730	Packaging	Including: export box, inner protection material
2	30706733	Export box	Excluding: inner protection material

10.2.8.4 Balances, compact

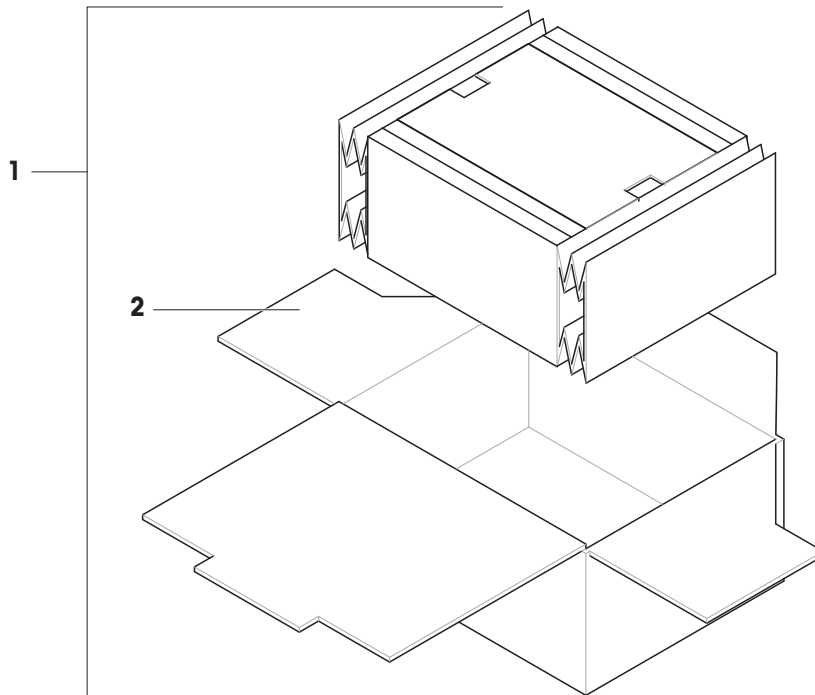

	Order no.	Designation	Remarks
1	30849997	Packaging	Including: export box, inner protection material
2	30850038	Export box	Excluding: inner protection material

11 Disposal

In conformance with the European Directive 2012/19/EU on Waste Electrical and Electronic Equipment (WEEE), this equipment may not be disposed of in domestic waste. This also applies to countries outside the EU, per their specific requirements.

Please dispose of this equipment in accordance with local regulations at the collecting point specified for electrical and electronic equipment. If you have any questions, please contact the responsible authority or the distributor from which you purchased this equipment. Should this equipment be passed on to other parties, the content of this directive must also be passed on to the other party.



12 Compliance Information

National approval documents, e.g., the FCC Supplier Declaration of Conformity, are available online and/or included in the packaging.

▶ www.mt.com/ComplianceSearch

Contact METTLER TOLEDO for questions about the country-specific compliance of your instrument.

▶ www.mt.com/contact

United States of America

This equipment has been tested and found to comply with the limits for a **Class A** digital device, pursuant to part 15 of the FCC Rules. These limits are designed to provide reasonable protection against harmful interference when the equipment is operated in a commercial environment. This equipment generates, uses, and can radiate radio frequency energy and, if not installed and used in accordance with the instruction manual, may cause harmful interference to radio communications. Operation of this equipment in a residential area is likely to cause harmful interference in which case the user will be required to correct the interference at his own expense.

This device complies with Part 15 of the FCC Rules. Operation is subject to the following two conditions:

1. This device may not cause harmful interference.
2. This device must accept any interference received, including interference that may cause undesired operation.

Changes or modifications not expressly approved by the party responsible for compliance could void the user's authority to operate the equipment.

Index

A

AC/DC adapter	78
acclimatization	
time	78
altitude	78
application	
check weighing	18, 40
density	18, 38
dynamic weighing	18, 37
factor weighing	18
formulation	18, 36
piece counting	18, 33
statistics	18, 43
totaling	18, 44
weighing	18, 32
auxiliary display	47
average	
see statistics	18

B

battery mode	29
below-the-balance weighing	31

C

check weighing	18, 40
compliance information	113
convention	5
cover	
protection	16

D

density	18, 38
device	
auxiliary display	47
foot switch	46
peripheral	45
printer	46
division factor weighing	18
dimension	92
display	
auxiliary	47
disposal	112
door	
handle	15
draft shield	15

draft shield door	
QuickLock	16
draft shield panel	
release button	16
drip tray	15
dynamic weighing	18, 37

E

environmental condition	20, 78
external	
device	45

F

factor weighing	18
foot switch	46
formulation	18, 36
Function PC-Direct	49

H

hibernation	28
humidity	78

I

install	
put into operation	25
site	20

L

level	
balance	25
indicator	11, 12
leveling feet	16
leveling feet	16
location	20

M

material	79
multiplication factor weighing	18

O

overview	
terminal	13, 14
type label	17

P

pack	
balance	31
PC-Direct	49

piece counting	18, 33
power consumption	
balance	78
power supply	
see AC/CD adapter	78
printer	46
protective cover	16

Q

QuickLock	
draft shield door	16

R

release button	
draft shield panel	16

S

safety information	9
software	
version	5
standard deviation	
see statistics	18, 43
standby	13, 27, 28
statistics	18, 43
store	
balance	31
switch on/off	28
symbol	5
warning	9

T

tare	13
temperature	78
acclimatization time	78
warm-up time	78
terminal	16
overview	13, 14
time	
acclimatization	78
warm up	78
totaling	18, 44
transport	
long distance	30
short distance	30
type label	
overview	17

U

unpack	
balance	20
USB	
see device	45

W

warm up	
time	78
warning symbol	9
weighing	18
application	32
weighing pan	15

Z

zero	13
------	----

To protect your product's future:

METTLER TOLEDO Service assures the quality, measuring accuracy and preservation of value of this product for years to come.

Please request full details about our attractive terms of service.

► www.mt.com/service

www.mt.com/MA-balances

For more information

Mettler-Toledo GmbH

Im Langacher 44
8606 Greifensee, Switzerland
www.mt.com/contact

Subject to technical changes.
© 07/2024 METTLER TOLEDO. All rights reserved.
30491855B en



30491855