

EasyClean systems

Technical data

Contents

What is EasyClean?	2
EasyClean 100	3
EasyClean 150	6
EasyClean 200e	10
Dimension drawings	15
Specifications	16



EasyClean 200e



Valve assembly

METTLER TOLEDO

What is EasyClean?

Automated in-line cleaning system for your sensors

Only a clean sensor can provide reliable and accurate measurement results. With our EasyClean systems, cleaning and calibration of sensors can be fully automated. Both the cleaning interval and the duration of flushing can be individually programmed for specific applications.

The EasyClean range starts with two comparatively basic versions intended for straightforward sensor flushing, the EasyClean 100 and EasyClean 150. These two systems are primarily intended for applications where contamination occurs in the form of water-soluble substances.

The EasyClean 200e can, besides the use of water alone, also be employed for cleaning with the aid of chemical solutions. Concentrated cleaning agent of your choice is pumped directly to the tip of the sensor. Cleaning and rinsing times as well as the cleaning interval can be adjusted individually.

Type	Function
EasyClean 100	flush
EasyClean 150	flush
EasyClean 200e	flush, chemical cleaning

Advantages through the employment of EasyClean:

- replacement/maintenance cost savings due to an extended lifetime of sensors
- higher safety standard through not having to remove the sensor during maintenance work
- increased process safety due to accurate, reliable measurement
- greater reproducibility of measurements for better process control
- defined and consistent product quality
- wide flexibility of system installation
- user-selectable cleaning medium/wide choice of cleaning media
- regular maintenance of poorly accessible installations.

Some typical applications

Wastewater:	Detoxification and neutralization of industrial wastewater
Pulp & paper:	Spreading on paper machines Bleaching process
CPI:	Optimization of dye manufacture Production of agrochemicals Monitoring of chemical reactions

EasyClean 100 – an ideal control unit for use with the InDip immersion housing



When taking measurements in open basins or channels, e.g., in wastewater neutralization plants, the sensor is mostly mounted in an immersion housing. This housing allows the sensor to be safely located in the basin or channel at a defined immersion depth. Conventional cleaning methods require removing the whole installation from the basin. Using EasyClean 100, this cleaning procedure can be fully automated, while the housing and sensor remain in the immersed position.

EasyClean 100 consists of a control unit and an additional spray head located at the submerged end of the InDip 550 immersion housing. Air or water is sprayed directly at the tip of the sensor to ensure effective cleaning. It is therefore completely unnecessary to remove the installation from its mounted position. Cleaning is carried out automatically through activation of the "Wash" contact in the associated transmitter. Depending upon the degree of contamination or fouling of the sensor, the cleaning interval and/or duration can be set individually as required.



Sensor cleaning with air using the cavitation effect.

Cavitation:

A localized low-pressure vaporization condition (cavities or bubbles) within a liquid, is not always appreciated. In our particular case, the sound and/or vibration on the sensor surface caused by bubble collapse is welcomed to remove contamination.

Dimensions EasyClean 100

For the exact dimensions relative to pipe/post or wall mounting, please refer to the specifications section on pages 14 and 15 of this documentation.

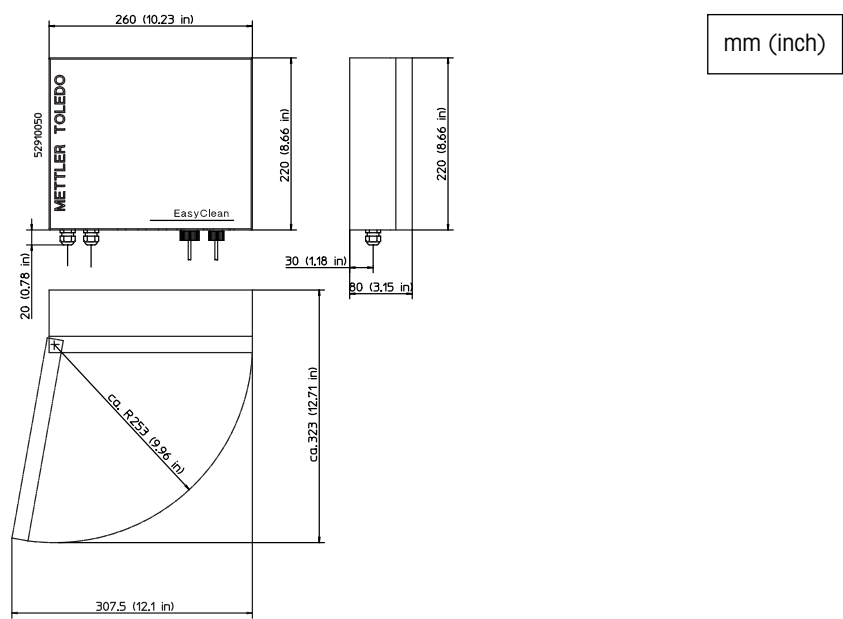

Electrical connections EasyClean 100

Electrical connections of EasyClean 100 and a transmitter.

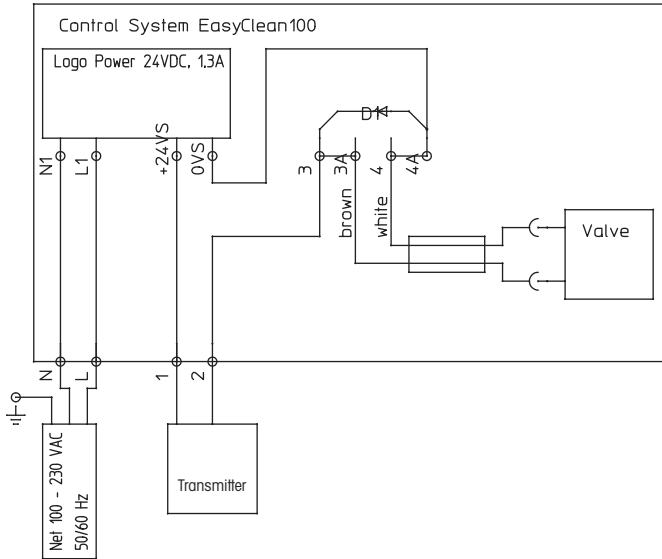

Electrical connections

Transmitter X100e

Define rinse interval and rinse time according to the process requirements on the transmitter X100e.

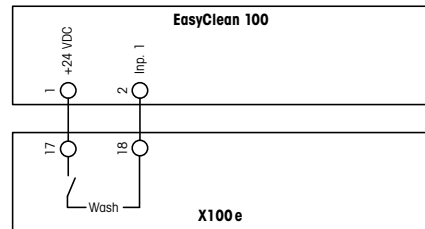

Transmitter M300

Set relay #1 (default) or #2, #3, #4 on the transmitter to rinse contact.

Define rinse interval and rinse time according to the process requirements on the transmitter M300.

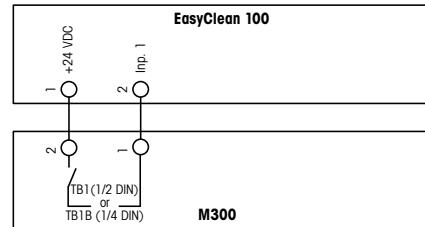

Transmitter M700

Set relays K3 (or K1 or K2) to rinse contact. Set it on NO (normally open).

Define the rinse interval and rinse time according to the process requirements.

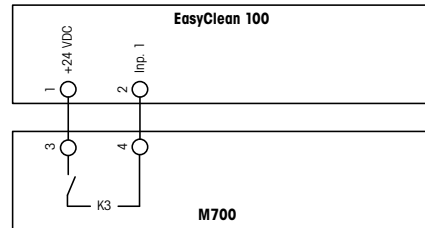

Transmitter Trb 8300

Define rinse interval and rinse time according to the process requirements on the transmitter Trb 8300.

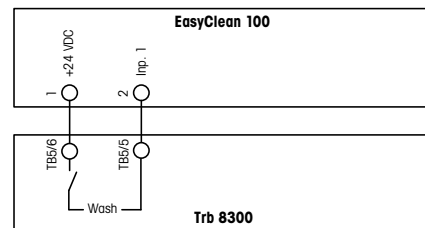

System configuration and ordering information EasyClean 100

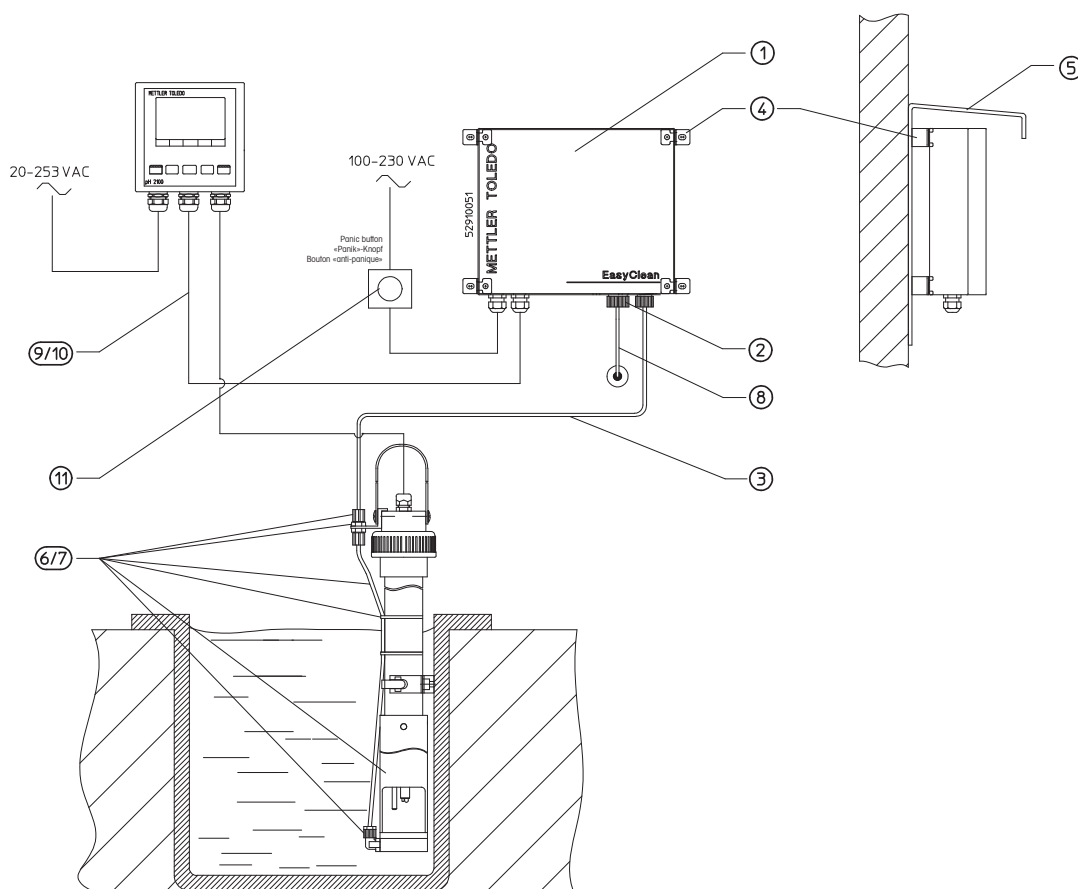

The EasyClean 100 delivery consists of the following:

N°	Designation	Order no.
1	EasyClean 100	52 402 304
2	Water connection: G 1/4" female or 1/4" NPT male	
3	Connecting hose: Ø 6/4 mm, length 5 m (16.4 ft), material LDPE → connection control unit → InDip	

Accessories and spare parts (to be ordered separately)

4	Wall mounting kit, complete	52 402 306
5	Weatherproof hood	52 402 316
6	Spray head for InDip 550/PVC	52 402 291
7	Spray head for InDip 550/PVDF	52 402 290
8	Hose LDPE for compressed air connection (20 m/65.6 ft)	52 402 314
9	Connecting cable: control unit → transmitter (5 m/16.4 ft)	52 300 265
10	Connecting cable: control unit → transmitter (10 m/32.8 ft)	52 300 266
11	Panic button (emergency shutdown)	52 402 317
	Pipe/post mounting kit, complete (description on page 15)	52 402 308
	Instruction manual EasyClean 100/150 (e/g/f)	52 500 178

EasyClean 150 – the ideal control unit for use with the InDip immersion housing



Sensors installed in a pipe or reaction vessel must be withdrawn from the process periodically for maintenance. The InTrac retractable housing features a flushing chamber that is safely sealed off from the process. Using an InTrac retractable housing, sensors can easily be removed from the medium for cleaning, maintenance, or replacement without process interruption.

The EasyClean 150 is the simplest, safest, and most cost-effective way to automate sensor flushing. The flushing cycle and its duration can be triggered automatically through the "Wash" contact in the transmitter, or performed manually by pressing the appropriate keys on the EasyClean control unit. The position of the retractable housing will be indicated through the EasyClean 150.

EasyClean 150 will work optimally with all pneumatic operated retractable housings such as the InTrac 777 e.

Dimensions EasyClean 150

For the exact dimensions relative to pipe/post or wall mounting, please refer to the specifications section on pages 14 and 15 of this documentation.

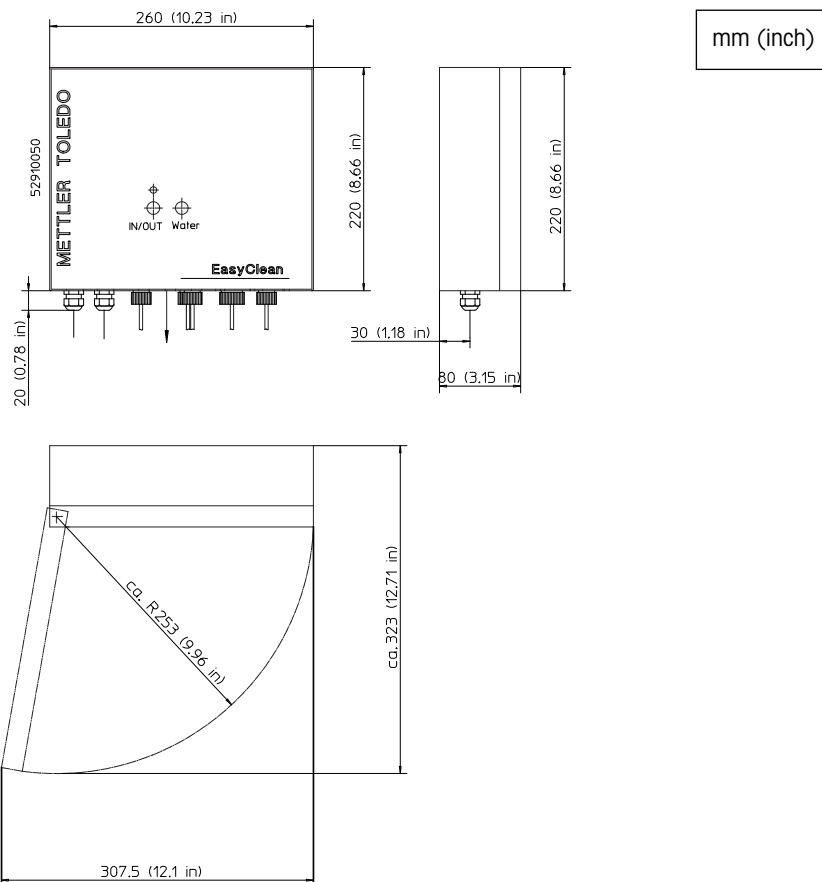

Electrical connections EasyClean 150

Electrical connections of EasyClean 150 and a transmitter.

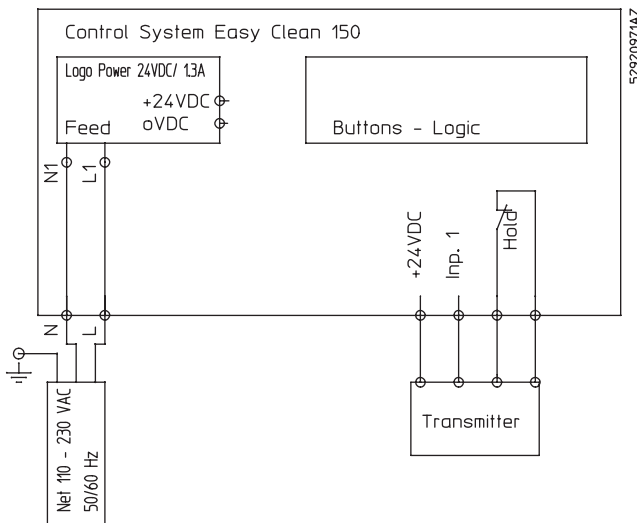

Electrical connections

Transmitter X100e

NOTICE
Bridge terminal 2 and 3 in the EasyClean 150.

Define rinse interval and rinse time according to the process requirements on the transmitter X100e.

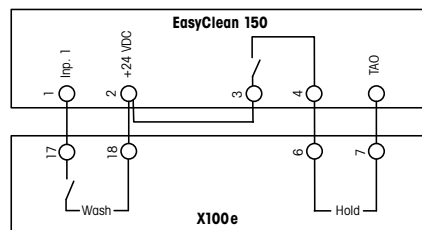

Transmitter M300

NOTICE
Bridge terminal 2 and 3 in the EasyClean 150.

Set relay #1 (default) or #2, #3, #4 on the transmitter to rinse contact.
Define rinse interval and rinse time according to the process requirements on the transmitter M300.

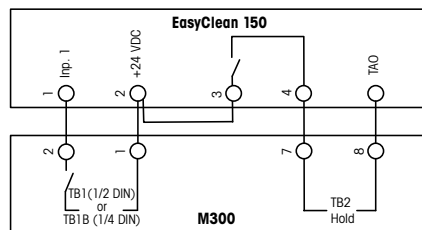

Transmitter M700

NOTICE
Bridge terminal 2 and 3 in the EasyClean 150.

Set relays K3 (or K1 or K2) to rinse contact and NO (normally open). Define the rinse interval and rinse time according to the process requirements.
Set input OK1 to HOLD (active 10–30 V) for the external hold signal.

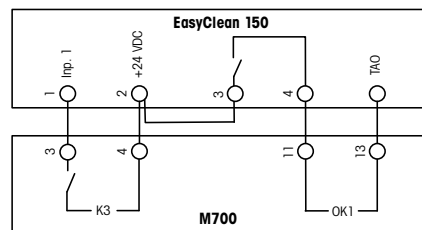

Transmitter Trb 8300

Define rinse interval and rinse time according to the process requirements on the transmitter Trb 8300.

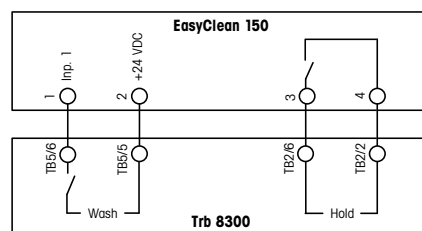

EasyClean 100 and 150 are designed to work together with Mettler Toledo transmitters. Please consult relevant instruction manuals of third party transmitters for proper installation.

System configuration and ordering information EasyClean 150

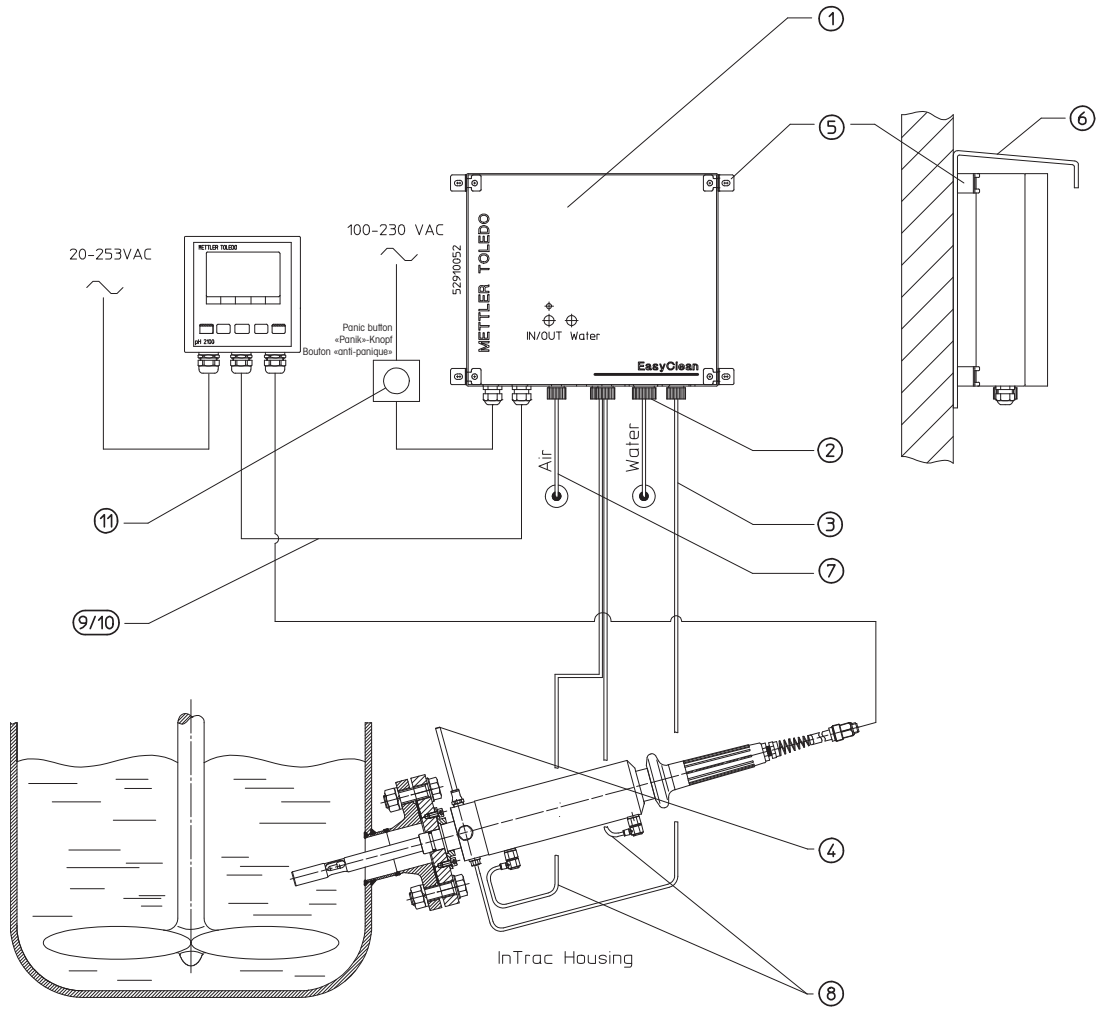

The EasyClean 150 delivery consists of the following:

N°	Designation	Order no.
1	EasyClean 150	52 402 319
2	Water connection: G 1/4" female or 1/4" NPT male	
3	Connecting hose: Ø 6/4 mm, length 5 m (16.4 ft), material LDPE → connection control unit → retractable housing	
4	Drainwater hose: Ø 6/4 mm, length 5 m (16.4 ft), material LDPE → connection retractable housing → drain	

Accessories and spare parts (to be ordered separately)		
3/4	Tubing PTFE 6/4 mm (5 m/16.4 ft)	52 402 283
5	Wall mounting kit, complete	52 402 306
6	Weatherproof hood	52 402 316
7	Hose LDPE for compressed air connection (20 m/65.6 ft)	52 402 314
8	Pneumatics hose PU 6/4 mm, (10 m/32.8 ft)	52 401 322
9	Connecting cable: control unit → transmitter (5 m/16.4 ft)	52 300 265
10	Connecting cable: control unit → transmitter (10 m/32.8 ft)	52 300 266
11	Panic button (emergency shutdown)	52 402 317
	Pipe/post mounting kit, complete (description on page 15)	52 402 308
	Instruction manual EasyClean 100/150 (e/g/f)	52 500 178

EasyClean 200e – chemical sensor cleaning system for use with InTrac retractable housings



Heavy contamination of sensors has a direct impact on their performance and serviceable life. Only a clean sensor can guarantee optimum performance and accuracy in a process. EasyClean 200e has been developed specially for the regular cleaning of sensors in processes where there is a latent risk of fouling. To avoid any changes in the potential of the sensor due to fouling, EasyClean 200e first flushes the sensor with water and then cleans it with an individual cleaning agent according to the degree of contamination. The cleaning cycle is activated by the "Wash" contact of the transmitter. EasyClean controls the entire cleaning sequence for a sensor fitted in an InTrac retractable housing.

The position of the retractable housing can be continuously monitored by an inductive position indicator. In the event of faulty operation of the system or of the retractable housing, the control unit of the EasyClean activates an alarm contact. Triggering of the cleaning cycle can be automated through the "Wash" contact in the transmitter, or manually by pressing the appropriate key on the EasyClean control unit.

Strict isolation of the electronics from the wet areas allows safe operation using appropriate cleaning solutions. The diaphragm pump installed in the valve assembly guarantees optimal cleaning at a predefined cleaning solution concentration.

Added accessories also allow the system to be adapted individually to suit local requirements.

Dimensions EasyClean 200e

For the exact dimensions relative to pipe/post or wall mounting, please refer to the specifications on pages 14 and 15 of this documentation.

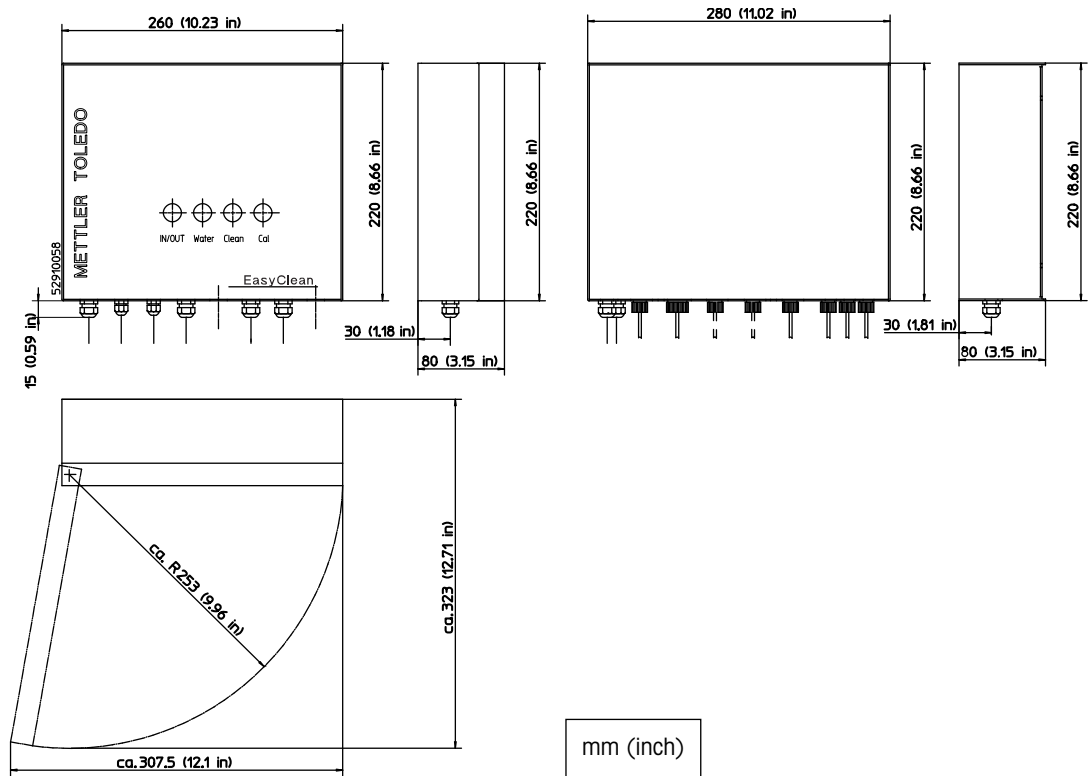

mm (inch)

Electrical connections EasyClean 200e

Electrical connections of EasyClean 200e and a transmitter.

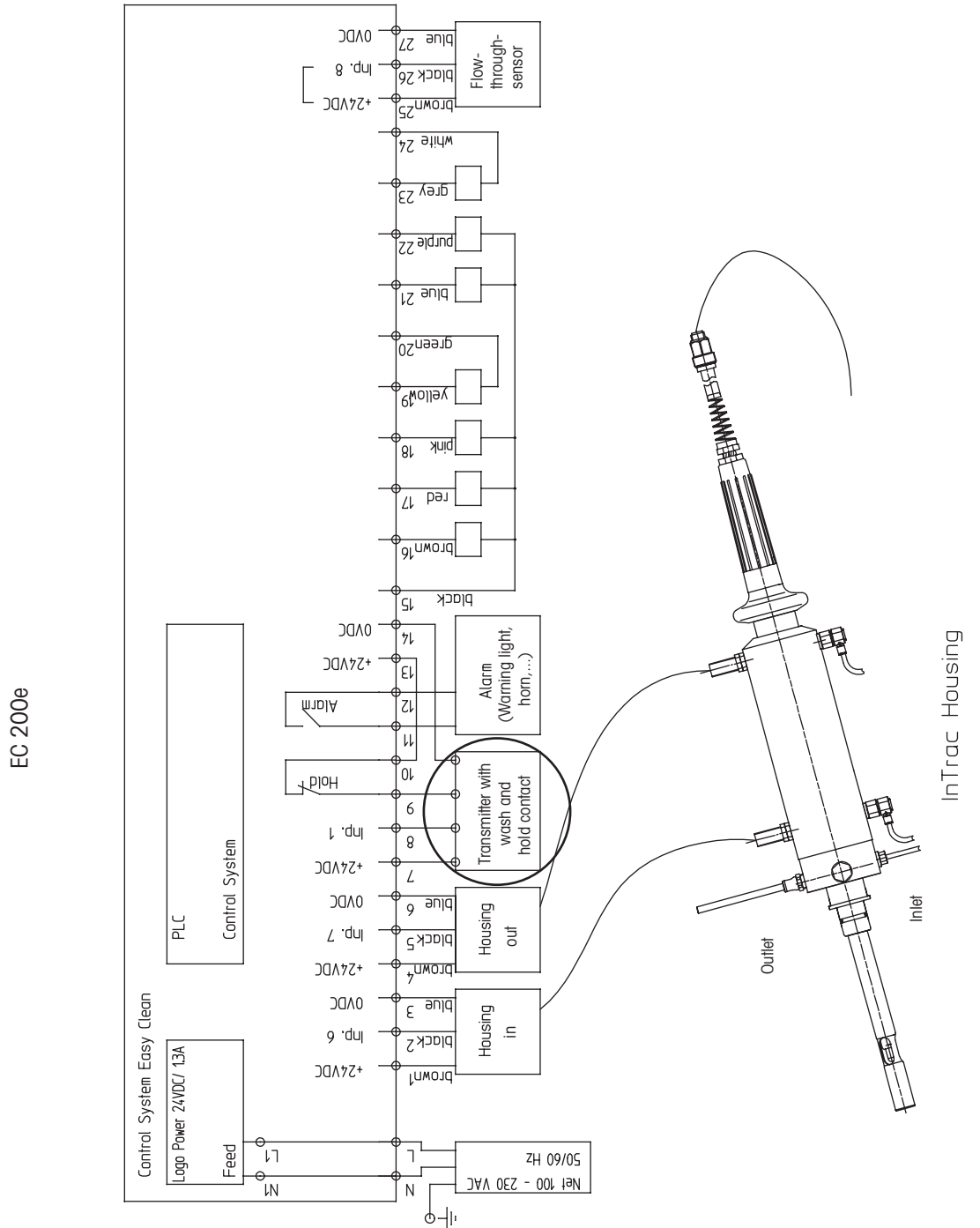

System configuration and ordering information EasyClean 200e

Transmitter X100e

NOTICE
Bridge terminal 10 and 13 in the EasyClean 200e.

Set rinse time to 5 sec. at the transmitter X100e and define the rinse interval according to the process requirements. Furthermore define rinse time (T2) and residence time for cleaning agent (T3) on the EasyClean 200e.

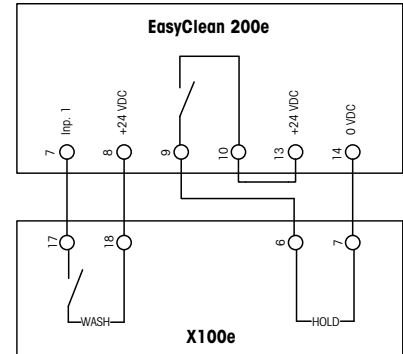

Transmitter M300

NOTICE
Bridge terminal 10 and 13 in the EasyClean 200e.

Set relay #1 (default) or #2, #3, #4 on the transmitter to rinse contact. Set rinse time to 5 sec. at the transmitter M300 and define the rinse interval according to the process requirements. Furthermore define rinse time (T2) and residence time for cleaning agent (T3) on the EasyClean 200e.

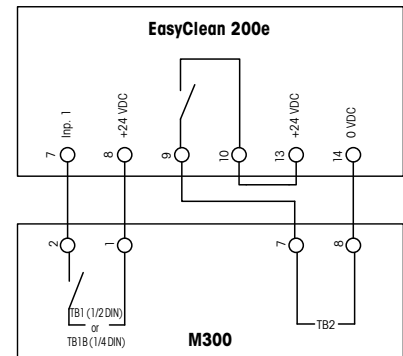

Transmitter M 700

NOTICE
Bridge terminal 10 and 13 in the EasyClean 200e.

Set relays K3 (K1 or K2) to rinse contact and NO (normally open). Set rinse time to 5 sec. at the transmitter M 700 and define the rinse interval according to the process requirements. Furthermore define rinse time (T2) and residence time for cleaning agent (T3) on the EasyClean 200e. Set input OK1 to HOLD (active 10–30V) for the external hold signal.

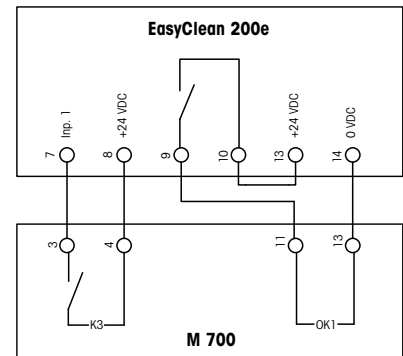

Transmitter Trb 8300

Set rinse time to 5 sec. at the transmitter Trb8300 and define the rinse interval according to the process requirements. Furthermore define rinse time (T2) and residence time for cleaning agent (T3) on the EasyClean 200e.

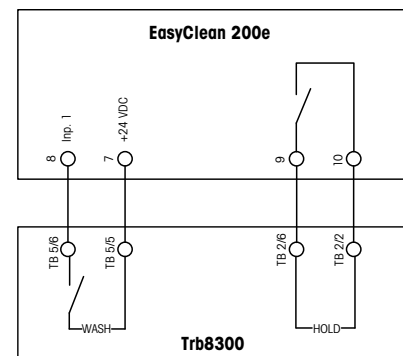

System configuration and ordering information EasyClean 200e

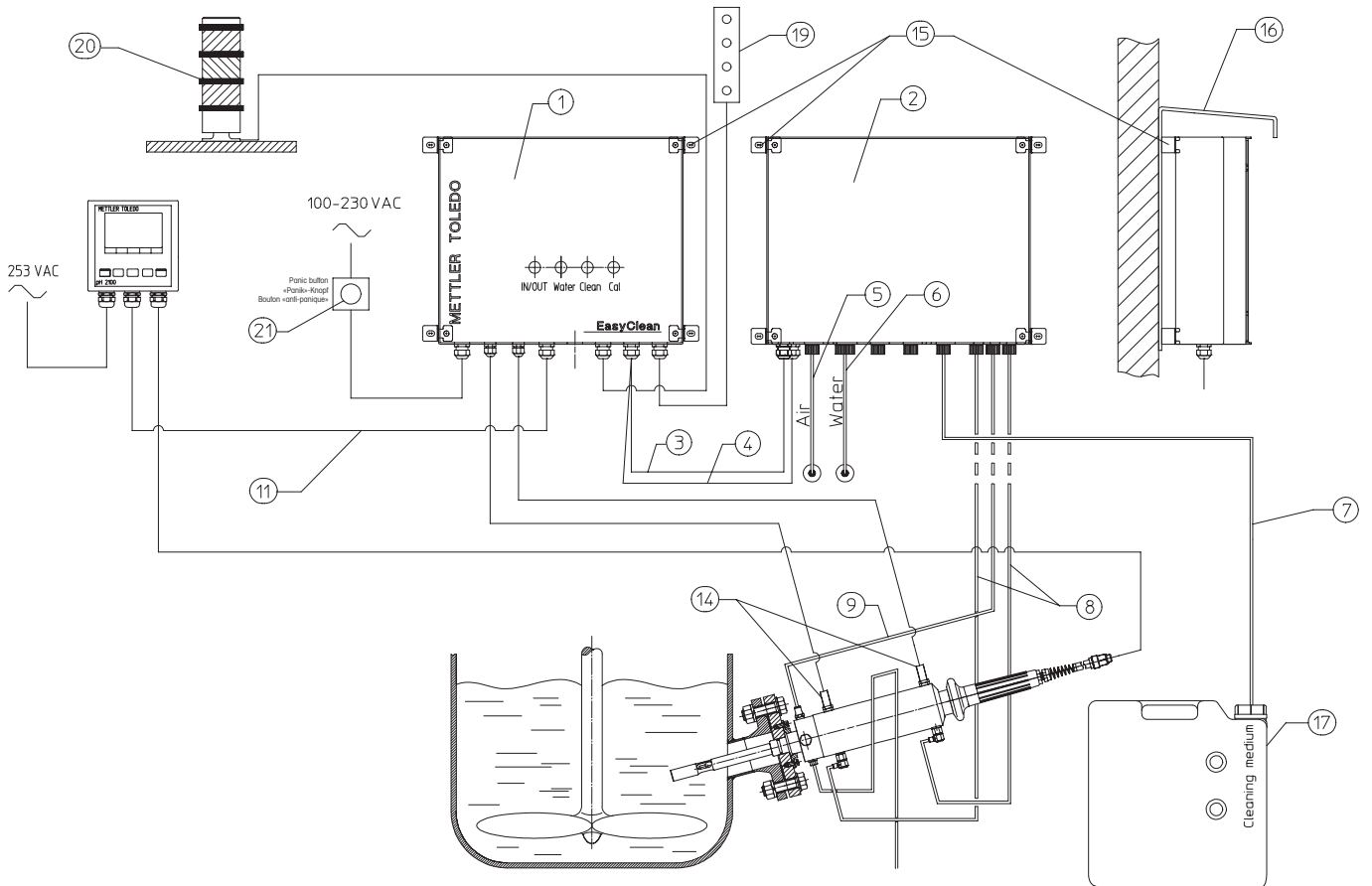

The EasyClean 200e delivery consists of the following:

N°	Description	Order no.
1	EasyClean 200e control unit with PLC (programable logic controller)	52 403 776
2	Valve assembly with valves for hydraulics and control air	
3	Connecting cable: control unit → valve assembly, 1.5 m (5 ft)	
6	Water connection: G 1/4" female or 1/4" NPT male	
	Tubing: ∅ 6/4 mm, length 20 m (65.6 ft), material LDPE	
8	EasyClean → InTrac (pneumatic)	
10	InTrac → drain	
	∅ 6/4 mm, length 10 m (32.8 ft), material PTFE	
9	EasyClean → InTrac (liquids)	
7	EasyClean → cleaning agent canister	

Optional accessories and installation material

4	Connecting cable: EasyClean 200e → valve unit (20 m/65.6 ft)	52 403 780
8	Tubing LDPE for compressed air connection (20 m/65.6 ft)	52 402 314
9	Tubing PTFE, ∅ 6/4 mm (5 m/16.4 ft)	52 402 283
11	Connecting cable: control unit → transmitter (5 m/16.4 ft)	52 300 265
11	Connecting cable: control unit → transmitter (10 m/32.8 ft)	52 300 266
14	Inductive check-back position indicators (2 pcs)	52 403 024
15	Wall mounting kit, complete	52 402 306
16	Weatherproof hood	52 402 316
17	Compact canister, 5000 ml/empty	52 118 063
19	Remote control	52 402 355
20	Warning light	52 402 351
21	Panic button (emergency shutdown)	52 402 317
	Pipe/post mounting kit, complete (description on page 15)	52 402 308
	Flow sensor (into valve assembly)	52 403 535

Documentation

	Instruction manual EasyClean 200e (e/g/f)	52 403 781
--	---	------------

Spare parts

	Power unit	52 402 305
	Print with PLC EasyClean	52 402 400
	Control unit EasyClean 200e	52 403 777
	Water and air valve	52 403 531
	Cleaning medium valve	52 403 530
	Valve assembly EasyClean 200e	52 403 778
	Air control valve housing	52 402 320
	Diaphragm pump	52 403 536
	Spare part kit pump	52 403 592

Wall mounting EasyClean 100/150/200e

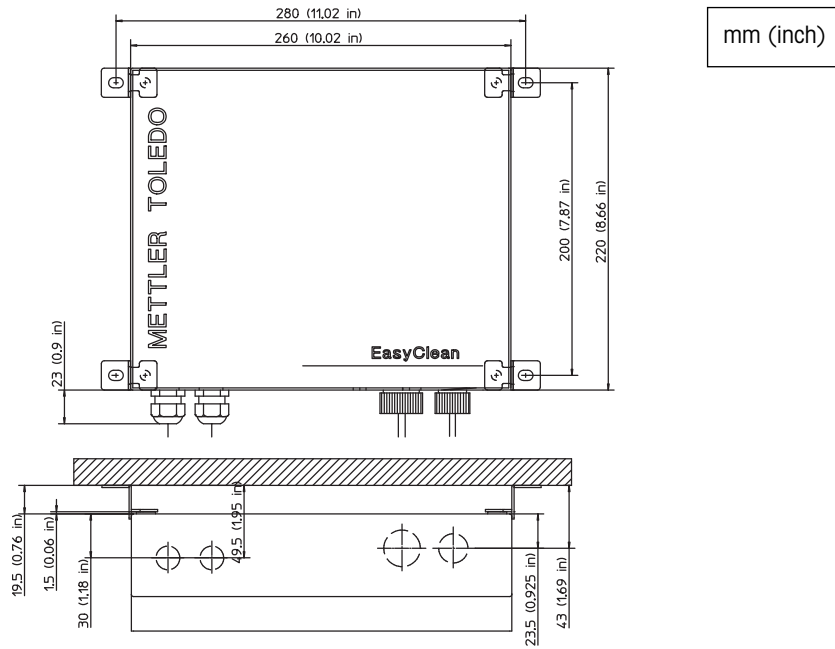

mm (inch)

Pipe/post mounting EasyClean

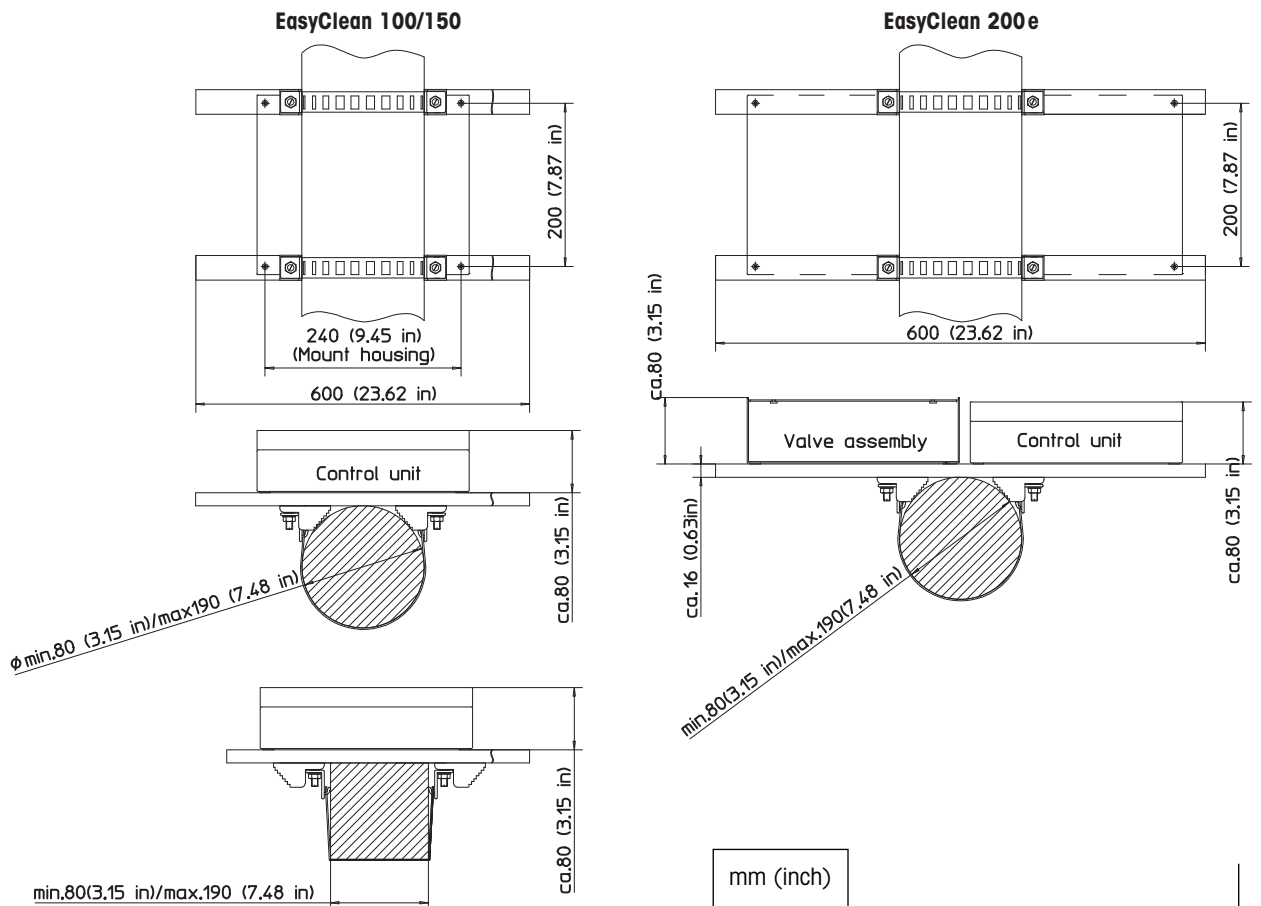

mm (inch)

Specifications

EasyClean 100/150/200 e

Product type	EasyClean 100/150	EasyClean 200 e
Housing	Steel housing, powder-coated with polyester resin material: Mild steel DIN 1.1203 Ck 55 Attention: housing may not be cleaned with solvents containing acetone	Steel housing, powder-coated with polyester resin material: Mild steel DIN 1.1203 Ck 55 Attention: housing may not be cleaned with solvents containing acetone
Weight of control unit	Approx. 3 kg (6.6 lbs)	Approx. 3 kg (6.6 lbs)
Weight of valve assembly	–	Approx. 2.5 kg (5.5 lbs)
Protection rating	IP 65	IP 65
Ambient conditions	Temperature in operation: 0 ... 55 °C (32 ... 131 °F) Transport/storage temperature: –10 ... +70 °C (+14 ... 158 °F) Degree of pollution: 2 Overvoltage category: III	Temperature in operation: 0 ... 55 °C (32 ... 131 °F) Transport/storage temperature: –10 ... +70 °C (+14 ... 158 °F) Degree of pollution: 2 Overvoltage category: III
Power supply	100 ... 230 V AC, 50/60 Hz, 0.18 ... 0.3 A (± 15%)	100 ... 230 V AC, 50/60 Hz, 0.18 ... 0.3 A (± 15%)
System control	Process initiation: via a "Wash" contact in the associated transmitter Sequence: cannot be set on unit	Process initiation: via a "Wash" contact in the associated transmitter Sequence: controlled by the integrated programmable PLC
Control input	1 control input for "Wash" contact in transmitter 24 V	1 control input for "Wash" contact in transmitter 24 V
Transmitter	METTLER TOLEDO transmitters: – X050 e, X100 e – M 700, Trb 8300 – alternatively through any standard transmitter with "Wash" contact and "Hold" function	METTLER TOLEDO transmitters: – X050 e, X100 e – M 700, Trb 8300 – alternatively through any standard transmitter with "Wash" contact and "Hold" function
Electr. connections	Terminal strip 0.08 ... 2.5 mm ²	Terminal strip 0.08 ... 2.5 mm ²
Connection to valve unit	–	10-wire control cable Length: standard 1.5 m (5 ft) optional 20 m (65.6 ft)
Connection to transmitter	4-wire control cable, 4 x 0.5 mm ² Length: 5 m (16.4 ft), optional 10 m (32.8 ft)	4-wire control cable, 4 x 0.5 mm ² Length: 5 m (16.4 ft), optional 10 m (32.8 ft)
Cable ducts	∅ 3.5 ... 10 mm → M 16	∅ 3.5 ... 10 mm → M 16 ∅ 2.5 ... 6.5 mm → M 12
Compressed air supply	4 ... 8 bar (400 ... 800 kPa, 58 ... 116 psi) Air quality according to ISO 8573-1 Moisture class 4 (dew point +3 °C) Particles class 5 (filter 40 µm) Max. oil content class 2 (0.1 mg/m ³) Connection: thread G ¹ / ₈ "	4 ... 8 bar (400 ... 800 kPa, 58 ... 116 psi) Air quality according to ISO 8573-1 Moisture class 4 (dew point +3 °C) Particles class 5 (filter 40 µm) Max. oil content class 2 (0.1 g/m ³) Connection: thread G ¹ / ₈ "

Specifications

EasyClean 100/150/200e

Product type	EasyClean 100/150	EasyClean 200e
Connection to InDip housing	Hose LDPE Tubing PTFE (optional) Ø 6/4 mm (1/8"/1/4")	–
Connection to retractable housing	Hose LDPE Tubing PTFE (optional) Ø 6/4 mm (1/8"/1/4")	Pneumatics: LDPE hose Ø 6/4 mm (1/8"/1/4"), control air Medium: PTFE hose Ø 6/4 mm (1/8"/1/4") Hose length typ. 5 m (16.4 ft) Hose length max. 10 m (32.8 ft)
Flushing water supply	Pressure: 2 ... 6 bar (200 ... 600 kPa, 29 ... 87 psi) Connection: thread G1/4" female Adapter: 1/4" NPT male (PP)	Pressure: 2 ... 8 bar (200 ... 800 kPa, 29 ... 116 psi) Connection: thread G1/4" female Adapter: 1/4" NPT male (PP) Particle filter: 50 µm Volume: ≥ 4 l/min.
Pump	–	Pump height: max. 5 m (16.5 ft.) Suction height: max. 3 m (9.8 ft.) Feed rate: 3 ... 5 ml/s (depending on hose length and viscosity) Materials: PPS (pump body) EPDM (membrane and sealings) Connection: thread G1/8" female, polymer (PP)
Viscosity	–	All liquids 25 mPa s/25 °C (77 °F)
Spray head material	PVC or PVDF	–
Wetted materials, in contact with	Flushing water, compressed air or cleaning medium: 1.4105, 1.4303, 1.4310 PP, LDPE, Viton®, brass,	Rinsing water: PP, EPDM, PTFE, PPS, Ni Compressed air: PP, EPDM, PTFE, PPS, LDPU, Ni Cleaning agents: PP, FFKM, PTFE, EPDM, PEEK
Liquid temperatures	–	Water: 0 ... 80 °C, max. 10 min/h at 95 °C (32 ... 176 °F, 203 °F) Cleaning agents: 0 ... 50 °C (32 ... 122 °F)

Conformity

Low voltage guidelines

- EU guidelines 73/23/EG
- Swiss guidelines SR734.26 NEV
- Safety regulations EN61010-1
- IP protection rating EN60529 IP65

EMC guidelines

- Emission EN61326-1, class B
- Harmonic oscillation EN61000-3-2
- Voltage fluctuation EN61000-3-3
- Immunity EN61326-1

Certificates

	CE	CSA C-US	GS	ATEX	UL Class I Div I	NEPSI
EasyClean 100	•	•	•	–	–	–
EasyClean 150	•	•	•	–	–	–
EasyClean 200e	•	•	•	–	–	–

Sales and Service:**Australia**

Mettler-Toledo Ltd.
220 Turner Street
Port Melbourne
AUS-3207 Melbourne/VIC
Phone +61 31300 659 761
Fax +61 3 9645 3935
e-mail info.mtaus@mt.com

Austria

Mettler-Toledo Ges.m.b.H.
Südrandstraße 17
A-1230 Wien
Phone +43 1 604 19 80
Fax +43 1 604 28 80
e-mail infoprocess.mtat@mtf.com

Brazil

Mettler-Toledo Ind. e Com. Ltda.
Alameda Araguaia
451 - Alphaville
BR-06455-000 Barueri/SP
Phone +55 11 4166 74 00
Fax +55 11 4166 74 01
e-mail sales@mettler.com.br
service@mettler.com.br

China

Mettler-Toledo Instruments
(Shanghai) Co. Ltd.
589 Gui Ping Road
Cao He Jing
CN-200233 Shanghai
Phone +86 21 64 85 04 35
Fax +86 21 64 85 33 51
e-mail mtcs@public.sta.net.cn

Croatia

Mettler-Toledo d.o.o.
Mandlova 3
HR-10000 Zagreb
Phone +385 1 292 06 33
Fax +385 1 295 81 40
e-mail mt.zagreb@mt.com

Czech Republic

Mettler-Toledo spol.s.r.o.
Trebohosticka 2283/2
CZ-100 00 Praha 10
Phone +420 2 72 123 150
Fax +420 2 72 123 170
e-mail sales.mtcz@mtf.com

Denmark

Mettler-Toledo A/S
Naverland 8
DK-2600 Glostrup
Phone +45 43 27 08 00
Fax +45 43 27 08 28
e-mail info.mtdk@mtf.com

France

Mettler-Toledo
Analyse Industrielle SAS
30, Boulevard de Douaumont
BP 949
F-75829 Paris Cedex 17
Phone +33 1 47 37 06 00
Fax +33 1 47 37 46 26
e-mail mtpro-f@mtf.com

Germany

Mettler-Toledo GmbH
Prozeßanalytik
Ockerweg 3
D-35396 Gießen
Phone +49 641 507 333
Fax +49 641 507 397
e-mail prozess@mtf.com

Great Britain

Mettler-Toledo LTD
64 Boston Road, Beaumont Leys
GB-Leicester LE4 1AW
Phone +44 116 235 7070
Fax +44 116 236 5500
e-mail enquire.mtuk@mtf.com

Hungary

Mettler-Toledo Kereskedelmi KFT
Teve u. 41
HU-1139 Budapest
Phone +36 1 288 40 40
Fax +36 1 288 40 50
e-mail mthu@axelero.hu

India

Mettler-Toledo India Private Limited
Amar Hill, Saki Vihar Road
Powai
IN-400 072 Mumbai
Phone +91 22 2857 0808
Fax +91 22 2857 5071
e-mail sales.mtin@mtf.com

Italy

Mettler-Toledo S.p.A.
Via Vialba 42
I-20026 Novate Milanese
Phone +39 02 333 321
Fax +39 02 356 2973
e-mail
customercare.italia@mtf.com

Japan

Mettler-Toledo K.K.
Process Division
4F Izumikan Sanbancho Bldg.
3-8 Sanbancho
Chiyoda-ku
JP-102-0075 Tokyo
Tel. +81 3 3222 7103
Fax +81 3 3222 7118
e-mail helpdesk.ing.jp@mtf.com

Malaysia

Mettler-Toledo (M) Sdn Bhd
Bangunan Electrocon Holding
Lot 8 Jalan Astaka U8/84
Seksyen U8, Bukit Jelutong
MY-40150 Shah Alam Selangor
Phone +60 3 78 44 58 88
Fax +60 3 78 45 87 73
e-mail
MT-MY.CustomerSupport@mtf.com

Mexico

Mettler-Toledo S.A. de C.V.
Pino No. 350, Col. Sta.
MA. Insurgentes, Col Atlampa
MX-06430 México D.F.
Phone +52 55 55 47 57 00
Fax +52 55 55 41 22 28
e-mail mt.mexico@mtf.com

Poland

Mettler-Toledo (Poland) Sp.z.o.o.
ul. Poleczki 21
PL-02-822 Warszawa
Phone +48 22 545 06 80
Fax +48 22 545 06 88
e-mail polska@mtf.com

Russia

Mettler-Toledo Vostok ZAO
Sretenskij Bulvar 6/1
Office 6
RU-101000 Moscow
Phone +7 495 621 92 11
Fax +7 495 621 63 53
+7 495 621 78 68
e-mail inforus@mtf.com

Singapore

Mettler-Toledo (S) Pte. Ltd.
Block 28
Ayer Rajah Crescent #05-01
SG-139959 Singapore
Phone +65 6890 00 11
Fax +65 6890 00 12
+65 6890 00 13
e-mail precision@mtf.com

Slovakia

Mettler-Toledo s.r.o.
Bulharska 61
SK-82104 Bratislava
Phone +421 244 44 12 20
Fax +421 244 44 12 23
e-mail predaj@mtf.com

Slovenia

Mettler-Toledo d.o.o.
Peske 12
SI-1236 Trzin
Phone +386 1 530 80 50
Fax +386 1 562 17 89
e-mail keith.racman@mtf.com

South Korea

Mettler-Toledo (Korea) Ltd.
Yeil Building 1 & 2 F
124-5, YangJe-Dong
SeCho-Ku
KR-137-130 Seoul
Phone +82 2 3498 3500
Fax +82 2 3498 3555
e-mail Sales_MTKR@mtf.com

Spain

Mettler-Toledo S.A.E.
C/ Miguel Hernández, 69-71
ES-08908 L'Hospitalet de Llobregat
(Barcelona)
Phone +34 93 223 76 00
Fax +34 93 223 76 01
e-mail bcn.centralita@mtf.com

Sweden

Mettler-Toledo AB
Virkesvägen 10
Box 92161
SE-12008 Stockholm
Phone +46 8 702 50 00
Fax +46 8 642 45 62
e-mail sales.mts@mtf.com

Switzerland

Mettler-Toledo (Schweiz) GmbH
Im Langacher
Postfach
CH-8606 Greifensee
Phone +41 44 944 45 45
Fax +41 44 944 45 10
e-mail salesola.ch@mtf.com

Thailand

Mettler-Toledo (Thailand) Ltd.
272 Soi Soonvijai 4
Rama 9 Rd., Bangkapi
Huay Kwang
TH-10320 Bangkok
Phone +66 2 723 03 00
Fax +66 2 719 64 79
e-mail
MT-TH.CustomerSupport@mtf.com

USA/Canada

Mettler-Toledo Ingold, Inc.
36 Middlesex Turnpike
Bedford, MA 01730, USA
Phone +1 781 301 8800
Toll free +1 800 352 8763
Fax +1 781 271 0681
e-mail mtprous@mtf.com
ingold@mtf.com



Management System
certified according to
ISO 9001 / ISO 14001

Subject to technical changes.
© Mettler-Toledo AG, Process Analytics
04/07 Printed in Switzerland. 52 500 185

Mettler-Toledo AG, Process Analytics
Industrie Nord, CH-8902 Urdorf, Switzerland
Tel. +41 44 729 62 11, Fax +41 44 729 66 36

www.mt.com/pro